



RRU3824&RRU3826

Hardware Description

Issue **04**

Date **2013-07-30**

Copyright © Huawei Technologies Co., Ltd. 2013. All rights reserved.

No part of this document may be reproduced or transmitted in any form or by any means without prior written consent of Huawei Technologies Co., Ltd.

Trademarks and Permissions



HUAWEI and other Huawei trademarks are trademarks of Huawei Technologies Co., Ltd.

All other trademarks and trade names mentioned in this document are the property of their respective holders.

Notice

The purchased products, services and features are stipulated by the contract made between Huawei and the customer. All or part of the products, services and features described in this document may not be within the purchase scope or the usage scope. Unless otherwise specified in the contract, all statements, information, and recommendations in this document are provided "AS IS" without warranties, guarantees or representations of any kind, either express or implied.

The information in this document is subject to change without notice. Every effort has been made in the preparation of this document to ensure accuracy of the contents, but all statements, information, and recommendations in this document do not constitute a warranty of any kind, express or implied.

Huawei Technologies Co., Ltd.

Address: Huawei Industrial Base
Bantian, Longgang
Shenzhen 518129
People's Republic of China

Website: <http://www.huawei.com>

Email: support@huawei.com

About This Document

Purpose

This document provides reference for planning and deploying DC blade RRU3824 and RRU3826 (referred to as RRU in this document). It presents the exterior and describes the ports, functions, cable types, connector specifications, and cable connections of the RRU.

Product Versions

The following table lists the product versions related to this document.

| Product Name | Product Version |
|---------------|--------------------------------|
| DBS3900 | V100R002C00 and later versions |
| DBS3800 WCDMA | V100R012C00 and later versions |
| DBS3900 WCDMA | V200R012C00 and later versions |

Intended Audience

This document is intended for:

- Base station installation engineers
- System engineers
- Site maintenance engineers

Organization

[1 Changes in RRU3824&RRU3826 Hardware Description](#)

This chapter describes the changes in *RRU3824&RRU3826 Hardware Description*.

[2 RRU Introduction](#)

This chapter describes the exterior and function of the RRU as well as the ports and indicators on the RRU.

3 RRU Cables

This chapter describes RRU cables.





4 RRU Auxiliary Devices

This chapter describes RRU auxiliary devices.

Conventions

Symbol Conventions

The symbols that may be found in this document are defined as follows.

| Symbol | Description |
|---|---|
|  DANGER | Indicates a hazard with a high level or medium level of risk which, if not avoided, could result in death or serious injury. |
|  WARNING | Indicates a hazard with a low level of risk which, if not avoided, could result in minor or moderate injury. |
|  CAUTION | Indicates a potentially hazardous situation that, if not avoided, could result in equipment damage, data loss, performance deterioration, or unanticipated results. |
|  TIP | Indicates a tip that may help you solve a problem or save time. |
|  NOTE | Provides additional information to emphasize or supplement important points of the main text. |

General Conventions

The general conventions that may be found in this document are defined as follows.

| Convention | Description |
|-----------------|--|
| Times New Roman | Normal paragraphs are in Times New Roman. |
| Boldface | Names of files, directories, folders, and users are in boldface . For example, log in as user root . |
| <i>Italic</i> | Book titles are in <i>italics</i> . |
| Courier New | Examples of information displayed on the screen are in Courier New. |

Command Conventions

The command conventions that may be found in this document are defined as follows.

| Convention | Description |
|------------------|---|
| Boldface | The keywords of a command line are in boldface . |
| <i>Italic</i> | Command arguments are in <i>italics</i> . |
| [] | Items (keywords or arguments) in brackets [] are optional. |
| { x y ... } | Optional items are grouped in braces and separated by vertical bars. One item is selected. |
| [x y ...] | Optional items are grouped in brackets and separated by vertical bars. One item is selected or no item is selected. |
| { x y ... }* | Optional items are grouped in braces and separated by vertical bars. A minimum of one item or a maximum of all items can be selected. |
| [x y ...]* | Optional items are grouped in brackets and separated by vertical bars. Several items or no item can be selected. |

GUI Conventions

The GUI conventions that may be found in this document are defined as follows.

| Convention | Description |
|-----------------|--|
| Boldface | Buttons, menus, parameters, tabs, window, and dialog titles are in boldface . For example, click OK . |
| > | Multi-level menus are in boldface and separated by the ">" signs. For example, choose File > Create > Folder . |

Keyboard Operations

The keyboard operations that may be found in this document are defined as follows.

| Format | Description |
|---------------------|---|
| Key | Press the key. For example, press Enter and press Tab . |
| Key 1+Key 2 | Press the keys concurrently. For example, pressing Ctrl+Alt+A means the three keys should be pressed concurrently. |
| Key 1, Key 2 | Press the keys in turn. For example, pressing Alt, A means the two keys should be pressed in turn. |

Mouse Operations

The mouse operations that may be found in this document are defined as follows.

| Action | Description |
|---------------|---|
| Click | Select and release the primary mouse button without moving the pointer. |
| Double-click | Press the primary mouse button twice continuously and quickly without moving the pointer. |
| Drag | Press and hold the primary mouse button and move the pointer to a certain position. |

Contents

| | |
|---|-----------|
| About This Document..... | ii |
| 1 Changes in RRU3824&RRU3826 Hardware Description..... | 1 |
| 2 RRU Introduction..... | 3 |
| 2.1 RRU Exterior..... | 4 |
| 2.2 RRU Functions..... | 4 |
| 2.3 RRU Technical Specifications..... | 5 |
| 2.4 RRU Ports..... | 5 |
| 2.5 RRU Indicators..... | 7 |
| 2.6 Optical Modules..... | 8 |
| 3 RRU Cables..... | 10 |
| 3.1 RRU Cable List..... | 12 |
| 3.2 RRU PGND Cable..... | 13 |
| 3.3 RRU Power Cable..... | 14 |
| 3.4 RRU Alarm Cable..... | 15 |
| 3.5 CPRI Fiber Optic Cable..... | 16 |
| 3.6 RRU RF Jumper..... | 20 |
| 3.7 Inter-RRU RF Cable..... | 20 |
| 3.8 RRU AISG Multi-Wire Cable..... | 21 |
| 3.9 RRU AISG Extension Cable..... | 22 |
| 4 RRU Auxiliary Devices..... | 24 |
| 4.1 IFS06..... | 25 |
| 4.2 OCB..... | 26 |

1 Changes in RRU3824&RRU3826 Hardware Description

This chapter describes the changes in *RRU3824&RRU3826 Hardware Description*.

04 (2013-07-30)

This is the fourth official release.

Compared with issue 03 (2013-04-28), this issue does not include any new information.

Compared with issue 03 (2013-04-28), this issue includes the following changes:

| Topic | Change Description |
|-------------------------------|---|
| 2.4 RRU Ports | Added a detailed description of the alarm port. |

Compared with issue 03 (2013-04-28), no information is deleted from this issue.

03 (2013-04-28)

This is the third official release.

Compared with issue 02 (2012-12-30), this issue includes the following new information:

- [2.6 Optical Modules](#)

Compared with issue 02 (2012-12-30), this issue includes the following changes:

| Topic | Change Description |
|--|---|
| 3.3 RRU Power Cable | Modified the length information of the cable. |
| 3.5 CPRI Fiber Optic Cable | Added information about the classification of CPRI fiber optic cables and the principles for selecting CPRI fiber optic cables. |

Compared with issue 02 (2012-12-30), no information is deleted from this issue.

02 (2012-12-30)

This is the second official release.

Compared with issue 01 (2012-09-13), this issue does not include any modification.

Compared with issue 01 (2012-09-13), this issue includes the following changes:

| Topic | Change Description |
|----------------------------------|---|
| 2.1 RRU Exterior | Modified the figures showing the RRU exterior, which has been modified. |
| 2.4 RRU Ports | |

Compared with issue 01 (2012-09-13), no information is deleted from this issue.

01 (2012-09-13)

This is the first official release.

2 RRU Introduction

About This Chapter

This chapter describes the exterior and function of the RRU as well as the ports and indicators on the RRU.

[2.1 RRU Exterior](#)

This section describes the exterior and dimensions of an RRU.

[2.2 RRU Functions](#)

This section describes the main functions of the RRU.

[2.3 RRU Technical Specifications](#)

This section describes technical specifications of an RRU, including supported modes, frequency bands, RF specifications, engineering specifications, and antenna capabilities.

[2.4 RRU Ports](#)

This section describes ports on the RRU panels. An RRU has a bottom panel, cabling cavity panel, and indicator panel.

[2.5 RRU Indicators](#)

This section describes six indicators on an RRU. They indicate the running status.

[2.6 Optical Modules](#)

An optical module transmits optical signals between an optical port and a fiber optic cable.

2.1 RRU Exterior

This section describes the exterior and dimensions of an RRU.

Figure 2-1 shows an RRU.

Figure 2-1 RRU exterior

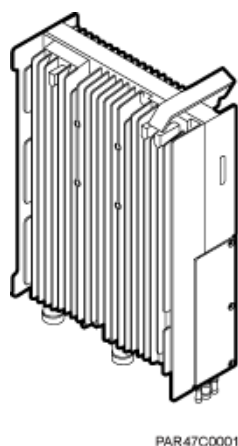
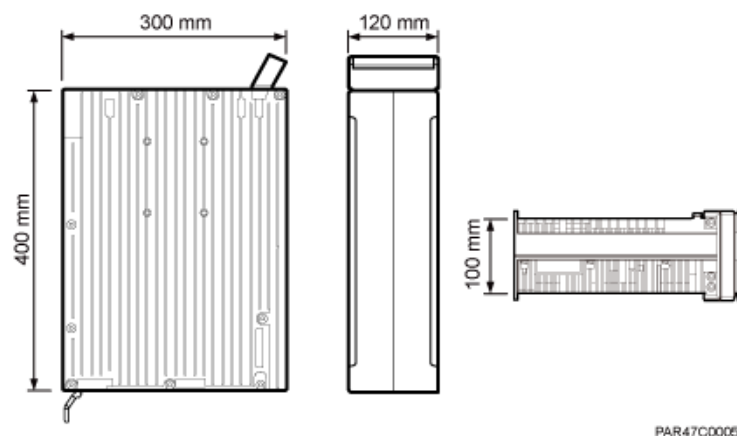

Figure 2-2 shows RRU dimensions.

Figure 2-2 RRU dimensions



2.2 RRU Functions

This section describes the main functions of the RRU.

The Remote Radio Unit (RRU) consists of the high-speed interface unit, signal processing unit, power amplifier, duplexer, extension ports, and power module. **Figure 2-3** shows the function structure of the RRU.

Figure 2-3 Function structure of the RRU

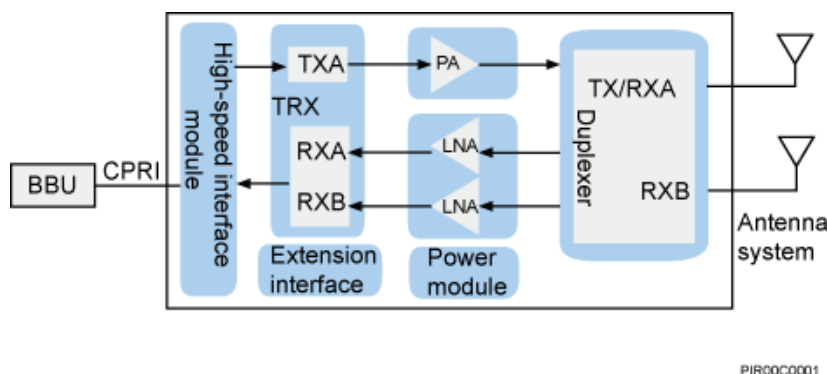

NOTE

For details about the extension ports, see [2.4 RRU Ports](#).

The RRU performs the following functions:

- Receives downlink baseband data from the BBU and sends uplink baseband data to the BBU.
- Receives RF signals from the antenna system, down-converts the signals to intermediate frequency (IF) signals, amplifies the IF signals, and performs analog-to-digital conversion. The transmit (TX) channel filters downlink signals, performs digital-to-analog conversion, and up-converts RF signals to the TX band.
- Multiplexes receive (RX) and TX signals on the RF channel, which enables these signals to share the same antenna path. It also filters the RX and TX signals.
- Provides a built-in Bias Tee (BT). The built-in BT couples RF signals and OOK signals and transmits them through the TX/RX port A. The built-in BT also supplies power to the tower mounted amplifier (TMA).
- The RRU can be powered by the AC/DC power module. In this case, this RRU is called AC RRU. For details about the AC/DC power module, see the *AC/DC Power Module User Guide*.

2.3 RRU Technical Specifications

This section describes technical specifications of an RRU, including supported modes, frequency bands, RF specifications, engineering specifications, and antenna capabilities.

For details about technical specifications of an RRU, see section "Technical Specifications of RRUs" in the *3900 Series Base Station Technical Description*.

2.4 RRU Ports

This section describes ports on the RRU panels. An RRU has a bottom panel, cabling cavity panel, and indicator panel.

[Figure 2-4](#) shows the ports on the RRU panels.

Figure 2-4 Ports on the RRU panels

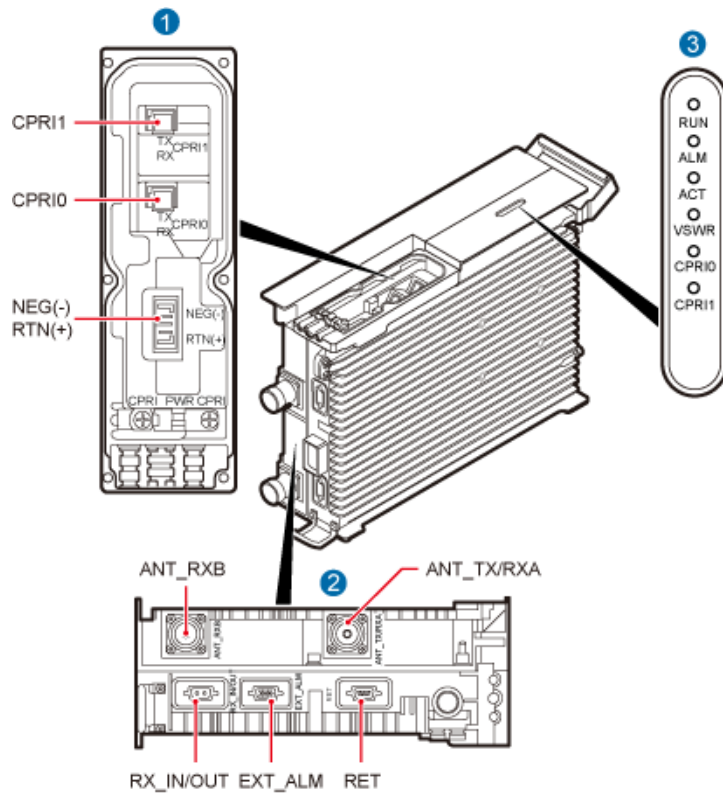

PAR48C0002

Table 2-1 describes ports and indicators on the RRU panels.

Table 2-1 Ports and indicators on the RRU panels

| Item | Silkscreen | Remarks |
|---------------------------------|------------|---|
| (1) Ports in the cabling cavity | RTN(+) | Power supply socket |
| | NEG(-) | |
| | CPRI0 | Optical/electrical port 0, connected to the BBU or an upper-level RRU |
| | CPRI1 | Optical/electrical port 1, connected to a lower-level RRU |
| (2) Ports at the bottom | ANT_TX/RXA | TX/RX port A, supporting RET signal transmission |
| | ANT_RXB | RX port B |
| | RX_IN/OUT | Interconnection port, used for RRU interconnection |

| Item | Silkscreen | Remarks |
|----------------|------------|--|
| | EXT_ALM | Alarm monitoring port used for monitoring one RS485 signal and two dry contact signals |
| | RET | Communication port for the RET antenna, supporting RET signal transmission |
| (3) Indicators | RUN | See 2.5 RRU Indicators . |
| | ALM | |
| | ACT | |
| | VSWR | |
| | CPRI0 | |
| | CPRI1 | |

 **NOTE**

The port for transmitting RET signals is determined by the software.

2.5 RRU Indicators

This section describes six indicators on an RRU. They indicate the running status.

For detailed positions of RRU indicators, see [2.4 RRU Ports](#).

[Table 2-2](#) describes RRU indicators.

Table 2-2 RRU indicators

| Indicator | Color | Status | Meaning |
|-----------|-------|---|---|
| RUN | Green | Steady on | There is power supply, but the module is faulty. |
| | | Steady off | There is no power supply, or the module is faulty. |
| | | Blinking (on for 1s and off for 1s) | The board is functioning properly. |
| | | Blinking (on for 0.125s and off for 0.125s) | Software is being loaded to the module, or the module is not started. |
| ALM | Red | Steady on | Alarms are generated, and the module must be replaced. |

| Indicator | Color | Status | Meaning |
|-----------|--------------|---|---|
| | | Blinking (on for 1s and off for 1s) | Alarms are generated. The alarms may be caused by the faults on the related boards or ports. Therefore, you need to locate the fault before deciding whether to replace the module. |
| | | Steady off | No alarm is generated. |
| ACT | Green | Steady on | The module is running properly with TX channels enabled or the software is being loaded without RRU running. |
| | | Blinking (on for 1s and off for 1s) | The module is running properly with TX channels disabled. |
| VSWR | Red | Steady off | No Voltage Standing Wave Ratio (VSWR) alarm is generated. |
| | | Steady on | VSWR alarms are generated. |
| CPRI0 | Red or green | Steady green | The CPRI link is functioning properly. |
| | | Steady red | An optical module fails to transmit or receive signals because the optical module is faulty or the fiber optic cable is broken. |
| | | Blinking red (on for 1s and off for 1s) | The CPRI link is out of lock because of a failure in clock lock between two modes or mismatched data rates over CPRI ports. |
| | | Steady off | The optical module cannot be detected, or the optical module is powered off. |
| CPRI1 | Red or green | Steady green | The CPRI link is functioning properly. |
| | | Steady red | An optical module fails to transmit or receive signals because the optical module is faulty or the fiber optic cable is broken. |
| | | Blinking red (on for 1s and off for 1s) | The CPRI link is out of lock because of a failure in clock lock between two modes or mismatched data rates over CPRI ports. |
| | | Steady off | The optical module cannot be detected, or the optical module is powered off. |

2.6 Optical Modules

An optical module transmits optical signals between an optical port and a fiber optic cable.

 **NOTE**

The exteriors of an optical module and the label on an optical module in this section are for reference only. The actual exteriors may be different.

Exterior

The following figure shows the exterior of an optical module.

Figure 2-5 Exterior of an optical module

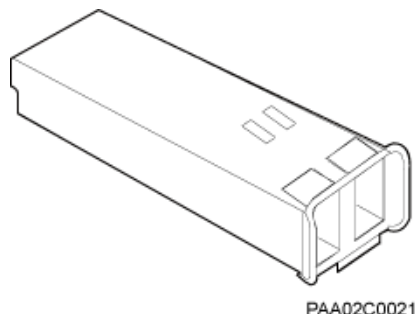

Label on an optical module

There is a label on each optical module, which provides information such as the rate, wavelength, and transmission mode, as shown in the following figure.

Figure 2-6 Label on an optical module

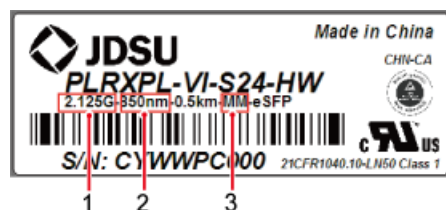

(1) Rate

(2) Wavelength

(3) Transmission mode

Optical Module Type

Optical modules can be divided into single- and multimode optical modules, which can be distinguished as follows:

- The puller of a single-mode optical module is blue and the puller of a multimode optical module is black or gray.
- The transmission mode is displayed as "SM" on the label of a single-mode optical module and "MM" on the label of a multimode optical module.

3 RRU Cables

About This Chapter

This chapter describes RRU cables.

3.1 RRU Cable List

This section describes RRU cable connections.

3.2 RRU PGND Cable

An RRU PGND cable connects an RRU and a ground bar, ensuring the proper grounding of the RRU. The maximum length of an RRU PGND cable is 8 m (26.25 ft).

3.3 RRU Power Cable

The RRU power cable is a -48 V DC shielded cable. It feeds -48 V DC power to an RRU. The maximum length of an RRU power cable delivered with RRUs is 50 m (164.04 ft) by default.

3.4 RRU Alarm Cable

The RRU alarm cable, a shielded straight-through cable, transmits alarm signals from an external device to an RRU so that the base station monitors the operating status of external devices. The RRU alarm cable is 5 m (16.4 ft).

3.5 CPRI Fiber Optic Cable

CPRI fiber optic cables are classified into multimode fiber optic cables and single-mode fiber optic cables. They transmit CPRI signals.

3.6 RRU RF Jumper

The 1/2" RRU RF jumper transmits and receives RF signals between an RRU and an antenna. A fixed-length RF jumper used by an RRU is 2 m (6.56 ft), 3 m (9.84 ft), 4 m (13.12 ft), 6 m (19.68 ft), or 10 m (32.81 ft). A variable-length RF jumper used by an RRU has a maximum length of 10 m (32.81 ft).

3.7 Inter-RRU RF Cable

An inter-RRU RF cable connects the RX_IN/OUT ports on two RRUs in the same cell and transmits RF signals between the RRUs. The length of the inter-RRU RF cable is 2 m (6.56 ft).

3.8 RRU AISG Multi-Wire Cable

An RRU AISG multi-wire cable connects an RRU and an RCU to transmit control signals from a base station to an RET antenna. When the RRU is connected to the RET antenna, an AISG multi-wire cable transmits RS485 signals. The length of the AISG multi-wire cable is 5 m (16.40 ft).

3.9 RRU AISG Extension Cable

When the distance between an RRU and an RCU is longer than 5 m (16.4 ft), an AISG multi-wire cable is not long enough to connect the RRU and the RCU. In this case, an AISG extension cable is used to extend the AISG multi-wire cable for transmitting RS485 signals. The length of the AISG extension cable is 15 m (49.21 ft).

3.1 RRU Cable List

This section describes RRU cable connections.

Table 3-1 lists RRU cables.

Table 3-1 RRU cables

| Cable | One End | | The Other End | |
|--------------------------------------|---|--|---|--|
| | Connector | Installation Position | Connector | Installation Position |
| 3.2 RRU PGND Cable | OT terminal (M6, 16 mm ² or 0.025 in. ²) | Ground terminal on the RRU | OT terminal (M8, 16 mm ² or 0.025 in. ²) | Ground terminal on the ground bar |
| 3.3 RRU Power Cable | Tool-less female connector (pressfit type) | NEG(-) and RTN(+) ports on the RRU | Depending on the power supply equipment | External power equipment |
| 3.4 RRU Alarm Cable | DB15 waterproof male connector | EXT_ALM port on the RRU | Cord end terminal | External alarm device |
| 3.5 CPRI Fiber Optic Cable | DLC connector | CPRI0 port on the RRU | DLC connector | CPRI port on a board in the BBU or CPRI1 port on the upper-level RRU |
| | | CPRI1 port on the RRU | | CPRI0 port on the lower-level RRU |
| 3.6 RRU RF Jumper | DIN male connector | ANT_TX/RXA or ANT_TX/RXB port on the RRU | DIN male connector | Antenna system |
| 3.7 Inter-RRU RF Cable | DB2W2 connector | RX_IN/OUT port on the RRU | DB2W2 connector | RX_IN/OUT port on the RRU |
| 3.8 RRU AISG Multi-Wire Cable | DB9 waterproof male connector | RET port on the RRU | Standard AISG female connector | Standard AISG male connector on the RCU or on the AISG extension cable |

| Cable | One End | | The Other End | |
|-------------------------------------|------------------------------|---|--------------------------------|---|
| | Connector | Installation Position | Connector | Installation Position |
| 3.9 RRU AISG Extension Cable | Standard AISG male connector | Standard AISG female connector on the AISG multi-wire cable | Standard AISG female connector | Standard AISG male connector on the RCU |

3.2 RRU PGND Cable

An RRU PGND cable connects an RRU and a ground bar, ensuring the proper grounding of the RRU. The maximum length of an RRU PGND cable is 8 m (26.25 ft).

Exterior

A PGND cable is green or green and yellow with a cross-sectional area of 16 mm² (0.025 in.²). An OT terminal is installed at each end of the cable. **Figure 3-1** shows a PGND cable.

Figure 3-1 PGND cable



(1) OT terminal (M6, 16 mm² or 0.025 in.²)

(2) OT terminal (M8, 16 mm² or 0.025 in.²)

NOTE

- If the customer prepares the PGND cable, a copper-core cable with a cross-sectional area of 16 mm² (0.025 in.²) or larger is recommended.
- One OT terminal must be added to each end of the PGND cable onsite.
- You can determine the color of the cable and whether to use corresponding two-hole OT terminals based on local regulations.

Figure 3-2 shows a two-hole OT terminal.

Figure 3-2 Two-hole OT terminal

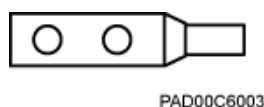

3.3 RRU Power Cable

The RRU power cable is a -48 V DC shielded cable. It feeds -48 V DC power to an RRU. The maximum length of an RRU power cable delivered with RRUs is 50 m (164.04 ft) by default.

NOTE

- The maximum length of power supply that an RRU power cable supports is 150 m (492.12 ft). Contact Huawei engineers when an RRU power cable greater than 50 m (164.04 ft) is required.
- If a power device provided by the customer is used, the recommended specification of the circuit breaker on this power device is 15 A to 30 A.

Exterior

There are two types of RRU power cables in terms of cross-sectional areas: 3.3 mm² (0.005 in.²) (12 AWG) complying with North American standards and 4 mm² (0.006 in.²) complying with European standards.

A tool-less female connector (pressfit type) needs to be added to one end of the RRU power cable and a corresponding terminal needs to be added to the other end based on the requirements of the connector on the external power device, as shown in [Figure 3-3](#).

Figure 3-3 RRU power cable

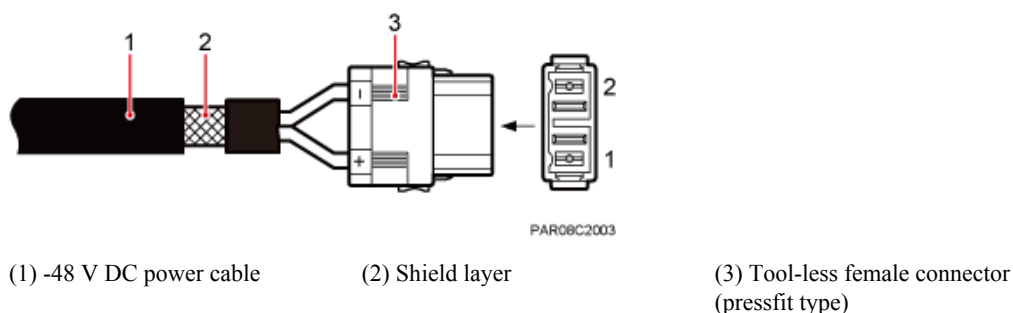

[Table 3-2](#) lists the specifications of an RRU power cable.

Table 3-2 Specifications of an RRU power cable

| Cable | Wire | Wire Color in Most Regions | | Wire Color in Other Regions |
|-----------------|--------|----------------------------|-------------------|-----------------------------|
| | | North American Standard | European Standard | UK |
| RRU power cable | RTN(+) | Black | Brown | Blue |
| | NEG(-) | Blue | Blue | Gray |

3.4 RRU Alarm Cable

The RRU alarm cable, a shielded straight-through cable, transmits alarm signals from an external device to an RRU so that the base station monitors the operating status of external devices. The RRU alarm cable is 5 m (16.4 ft).

Exterior

An alarm cable has a DB15 waterproof male connector at one end and eight cord end terminals at the other end, as shown in [Figure 3-4](#).

Figure 3-4 Alarm cable

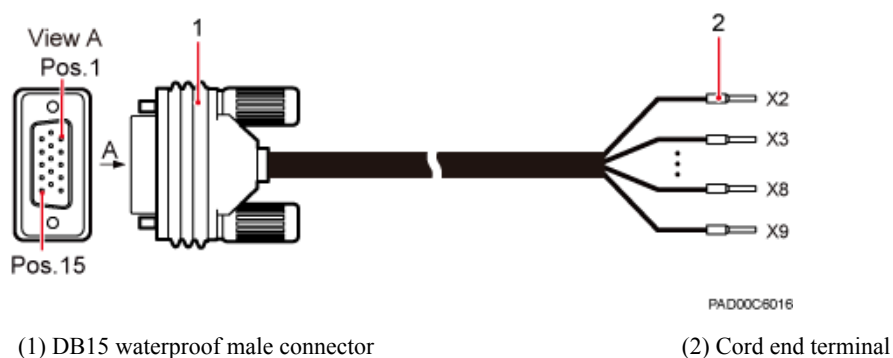

Pin Assignment

[Table 3-3](#) describes the pin assignment for the wires of an RRU alarm cable.

Table 3-3 Pin assignment for the wires of an RRU alarm cable

| RRU Alarm Port | Pin of the Waterproofed DB15 Male Connector | Color | Type | Cord End Terminal | Description |
|----------------|---|------------------|--------------|-------------------|---------------------|
| Dry contact | X1.2 | White and blue | Twisted pair | X2 | SWITCH_INPUT0+ |
| | X1.3 | Blue | | X3 | SWITCH_INPUT0-(GND) |
| | X1.6 | White and orange | Twisted pair | X4 | SWITCH_INPUT1+ |
| | X1.7 | Orange | | X5 | SWITCH_INPUT1-(GND) |

| RRU Alarm Port | Pin of the Waterproofed DB15 Male Connector | Color | Type | Cord End Terminal | Description |
|----------------|---|-----------------|--------------|-------------------|-------------|
| RS485 | X1.10 | White and green | Twisted pair | X6 | APM RX- |
| | X1.11 | Green | | X7 | APM RX+ |
| | X1.13 | White and brown | Twisted pair | X8 | APM TX- |
| | X1.14 | Brown | | X9 | APM TX+ |

3.5 CPRI Fiber Optic Cable

CPRI fiber optic cables are classified into multimode fiber optic cables and single-mode fiber optic cables. They transmit CPRI signals.

Multimode fiber optic cables connect the BBU and RRU or interconnect two RRUs. The maximum length of the multimode fiber optic cable between the BBU and RRU is 150 m (492.12 ft) and the multimode fiber optic cable between two RRUs has a fixed length of 10 m (32.81 ft).

A single-mode fiber optic cable consists of the single-mode pigtail and trunk single-mode fiber optic cable, and the single-mode pigtail and trunk single-mode fiber optic cable are interconnected using the ODF. The maximum length of the single-mode pigtail is 20 m (65.62 ft) on BBU side and 70 m (229.66 ft) on RRU side.

NOTE

- The ODF and trunk single-mode fiber optic cable are provided by the customer and must comply with the ITU-T G.652 standard.
- The ODF is an outdoor transfer box for fiber optic cables, which interconnects the single-mode pigtail and trunk single-mode fiber optic cable.
- A multimode fiber optic cable and a single-mode fiber optic cable are connected to a multimode optical module and a single-mode optical module, respectively.

Exterior

Multimode fiber optic cable: The multimode fiber optic cable has a DLC connector at each end, as shown in [Figure 3-5](#).

Figure 3-5 Multimode fiber optic cable

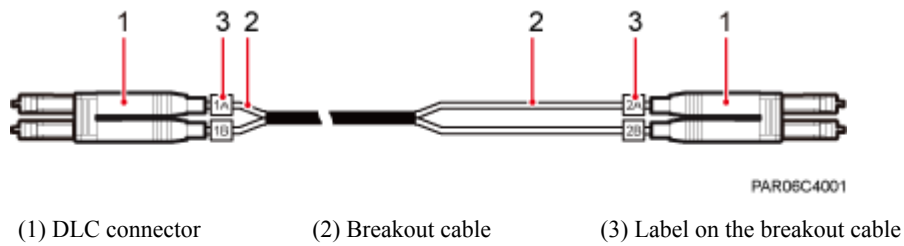

NOTE

- When a multimode fiber optic cable connects a BBU and an RRU, the breakout cable on the BBU side is 0.34 m (1.12 ft) and the breakout cable on the RRU side is 0.03 m (0.098 ft).
- When a multimode fiber optic cable connects two RRUs, the breakout cable on both sides is 0.03 m (0.098 ft).

Figure 3-6 shows the connection of the multimode fiber optic cable between a BBU and an RRU.

Figure 3-6 Connection of the multimode fiber optic cable between a BBU and an RRU

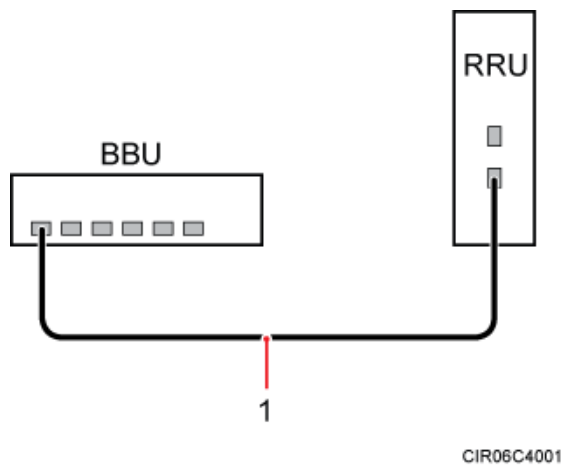

(1) Multimode fiber optic cable between a BBU and an RRU

Single-mode pigtail: The single-mode pigtail has a DLC connector at one end and an FC, LC, or SC connector at the other end, as shown in **Figure 3-7**.

Figure 3-7 Single-mode pigtail

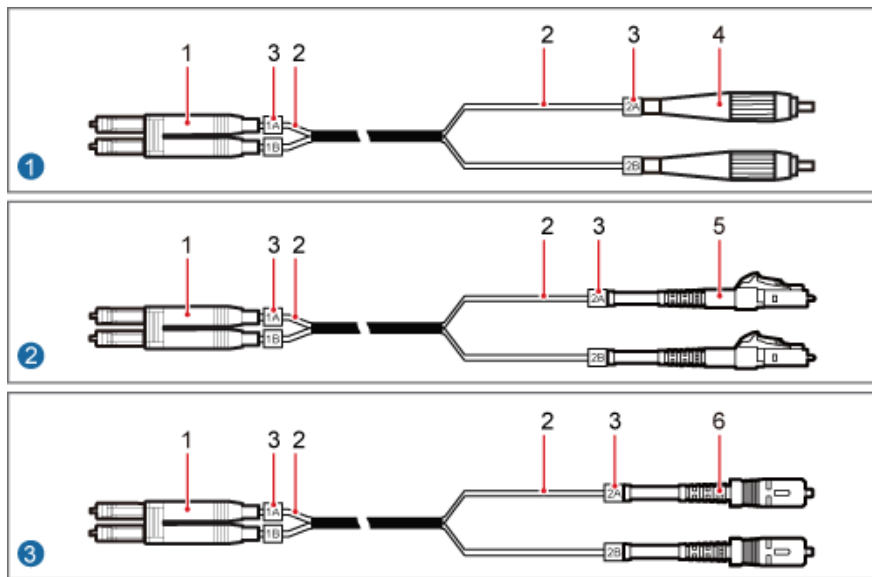

PAR06C4002

- (1) DLC connector (2) Breakout cable (3) Label on the breakout cable (4) FC connector (5) LC connector (6) SC connector

NOTE

- When a single-mode pigtail connects a BBU and an ODF, the breakout cables on the BBU side and ODF side are 0.34 m (1.12 ft) and 0.8 m (2.62 ft), respectively.
- When a single-mode pigtail connects an RRU and an ODF, the breakout cables on the RRU side and ODF side are 0.03 m (0.098 ft) and 0.8 m (2.62 ft), respectively.

Figure 3-8 shows the connection of the single-mode pigtail.

Figure 3-8 Connection of the single-mode pigtail

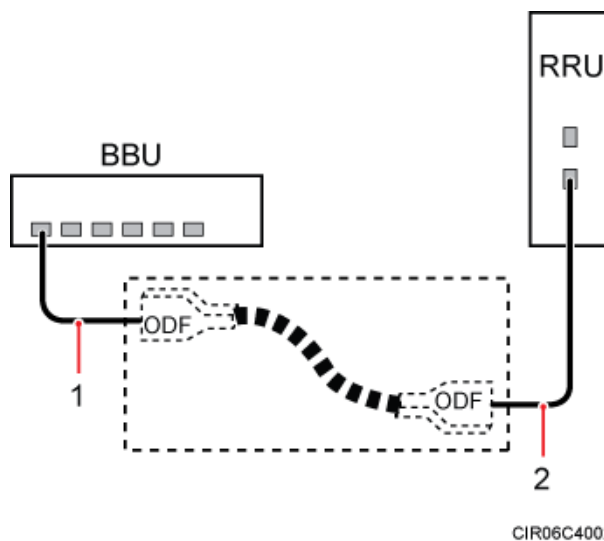

CIR06C4002

- (1) Single-mode pigtail between a BBU and an ODF (2) Single-mode pigtail between an RRU and an ODF

Selection Principles

The following table describes the principles for selecting CPRI fiber optic cables.

Table 3-4 Principles for selecting CPRI fiber optic cables

| Remote Distance | Selection Principle | Remarks |
|--|--|---|
| Less than or equal to 100 m (328.08 ft) | Multimode fiber optic cable | Connects the BBU and RRU When it connects two RRUs, the distance between the two RRUs must be equal to or less than 10 m (32.81 ft). |
| Greater than 100 m (328.08 ft) and equal to or less than 150 m (492.12 ft) | Multimode fiber optic cable | Connects the BBU and RRU |
| | Recommended: single-mode fiber optic cable (single-mode pigtail and trunk single-mode fiber optic cable) | The single-mode pigtail at the RRU or BBU side is connected to the trunk single-mode fiber optic cable using the ODF. |
| Greater than 150 m (492.12 ft) | Single-mode fiber optic cable (single-mode pigtail and trunk single-mode fiber optic cable) | |

Pin Assignment

Table 3-5 describes the labels on and recommended connections for the breakout cables of a CPRI fiber optic cable.

Table 3-5 Labels on and recommended connections for the breakout cables of a CPRI fiber optic cable

| Label | Installation Position | | |
|-------|--|--|---|
| | Multimode Fiber Optic Cable Between a BBU and an RRU | Multimode Fiber Optic Cable Between Two RRUs | Single-Mode Pigtail |
| 1A | CPRI RX port on the RRU | CPRI RX port on RRU 1 | RX port on the BBU or CPRI RX port on the RRU |
| 1B | CPRI TX port on the RRU | CPRI TX port on RRU 1 | TX port on the BBU or CPRI TX port on the RRU |
| 2A | TX port on the BBU | CPRI TX port on RRU 0 | ODF |
| 2B | RX port on the BBU | CPRI RX port on RRU 0 | ODF |

3.6 RRU RF Jumper

The 1/2" RRU RF jumper transmits and receives RF signals between an RRU and an antenna. A fixed-length RF jumper used by an RRU is 2 m (6.56 ft), 3 m (9.84 ft), 4 m (13.12 ft), 6 m (19.68 ft), or 10 m (32.81 ft). A variable-length RF jumper used by an RRU has a maximum length of 10 m (32.81 ft).

NOTE

- When the distance between an RRU and an antenna is less than 10 m (32.81 ft), one end of the RF jumper is connected to the ANT-TX/RXA or ANT-TX/RXB port at the bottom of the RRU, and the other end is connected to the antenna.
- When the distance between an RRU and an antenna is greater than 10 m (32.81 ft), one end of the RF jumper is connected to a feeder, and the other end is connected to the antenna.
- If the customer prepares the RF jumper, the length of the RF jumper should be as short as possible and not exceed 2 m (6.56 ft).

Exterior

An RF jumper has a DIN male connector at one end and a customized connector at the other end.

Figure 3-9 shows an RF jumper with a DIN male connector at each end.

Figure 3-9 RF jumper



(1) DIN male connector

3.7 Inter-RRU RF Cable

An inter-RRU RF cable connects the RX_IN/OUT ports on two RRUs in the same cell and transmits RF signals between the RRUs. The length of the inter-RRU RF cable is 2 m (6.56 ft).

Exterior

Figure 3-10 shows an inter-RRU RF cable with a DB2W2 connector at each end.

Figure 3-10 Inter-RRU RF cable

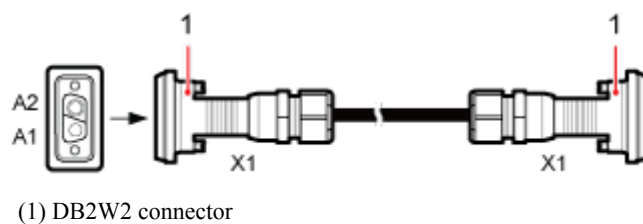

3.8 RRU AISG Multi-Wire Cable

An RRU AISG multi-wire cable connects an RRU and an RCU to transmit control signals from a base station to an RET antenna. When the RRU is connected to the RET antenna, an AISG multi-wire cable transmits RS485 signals. The length of the AISG multi-wire cable is 5 m (16.40 ft).

NOTE

An RCU is a driving motor used for the phase shifter in the RET antenna. It receives control commands from a base station and runs the commands to drive the stepper motor. Using a gear, the stepper motor drives the adjustable phase shifter in the antenna and changes the downtilt angle.

Exterior

An AISG multi-wire cable has a waterproofed DB9 male connector at one end and a standard AISG female connector at the other end, as shown in [Figure 3-11](#).

Figure 3-11 AISG multi-wire cable

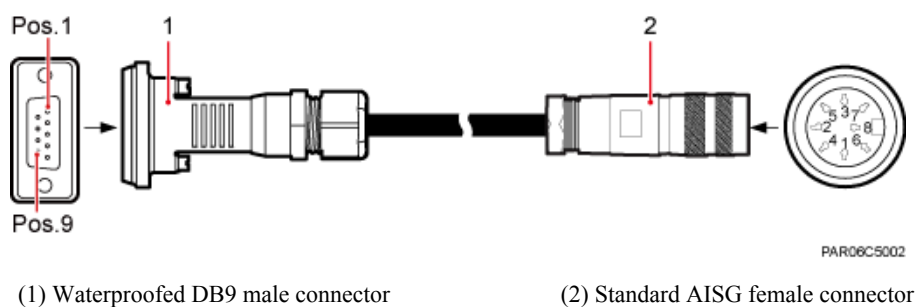

Pin Assignment

[Table 3-6](#) describes the pin assignment for the wires of an AISG multi-wire cable.

Table 3-6 Pin assignment for the wires of an AISG multi-wire cable

| X1 End (Pin of the Waterproofed DB9 Male Connector) | X2 End (Pin of the Standard AISG Female Connector) | Color | Type | Description |
|---|--|------------------|--------------|-------------|
| X1.1 | X2.1 | White and blue | Twisted pair | +12 V |
| | | Blue | | |
| X1.3 | X2.3 | White and orange | Twisted pair | RS485 B |
| X1.5 | X2.5 | Orange | | RS485 A |
| X1.4 | X2.4 | White and green | - | GND |
| X1.9 and X1.4 are interconnected. | - | - | - | GND |
| - | X2.1 and X2.6 are interconnected. | - | - | +12 V |
| - | X2.4 and X2.7 are interconnected. | - | - | GND |

3.9 RRU AISG Extension Cable

When the distance between an RRU and an RCU is longer than 5 m (16.4 ft), an AISG multi-wire cable is not long enough to connect the RRU and the RCU. In this case, an AISG extension cable is used to extend the AISG multi-wire cable for transmitting RS485 signals. The length of the AISG extension cable is 15 m (49.21 ft).

Exterior

An AISG multi-wire cable has a standard AISG male connector at one end and a standard AISG female connector at the other end, as shown in [Figure 3-12](#).

Figure 3-12 AISG extension cable

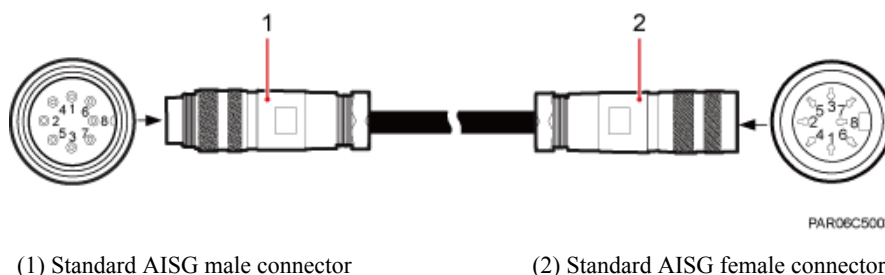

Pin Assignment

Table 3-7 describes the pin assignment for the wires of an AISG extension cable.

Table 3-7 Pin assignment for the wires of an AISG extension cable

| X1 End (Pin of the Standard AISG Male Connector) | X2 End (Pin of the Standard AISG Female Connector) | Color | Type | Description |
|--|--|------------------|--------------|-------------|
| X1.1 | X2.1 | White and blue | Twisted pair | +12 V |
| | | Blue | | |
| X1.7 | X2.7 | White and orange | Twisted pair | DC Return |
| | | Orange | | |
| X1.3 | X2.3 | White and green | Twisted pair | RS485 B |
| X1.5 | X2.5 | Green | | RS485 A |
| X1.6 | X2.6 | White and brown | Twisted pair | +24 V |
| | | Brown | | |

4 RRU Auxiliary Devices

About This Chapter

This chapter describes RRU auxiliary devices.

4.1 IFS06

An Indoor Floor installation Support (IFS06) is used for installing indoor RRUs.

4.2 OCB

An Outdoor Cable Conversion Box (OCB) interconnects cables of different core diameters. Power cables shipped with RRUs cannot support long-distance power supply. Therefore, when power supply is far from the equipment, cables with large core diameters are used, and an OCB connects these cables and RRU power cables.

4.1 IFS06

An Indoor Floor installation Support (IFS06) is used for installing indoor RRUs.

Exterior

Figure 4-1 shows an IFS06.

Figure 4-1 IFS06

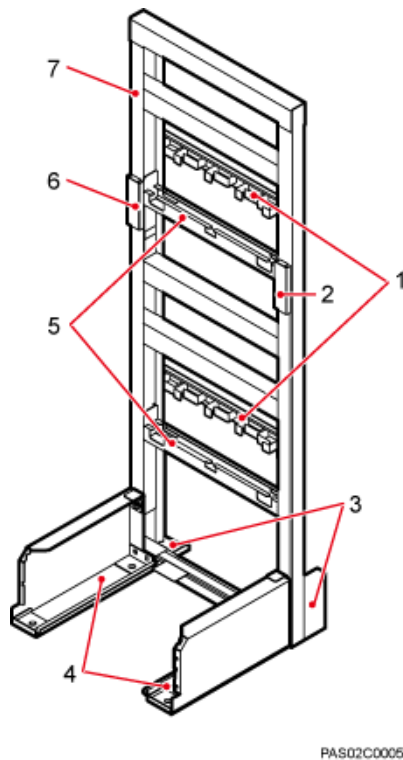

| | | | |
|---------------------|------------------|----------------|----------------|
| (1) Cable tray | (2) Ground bar 2 | (3) Rear foot | (4) Front foot |
| (5) Adjustable beam | (6) Ground bar 1 | (7) Main frame | - |

Function

- It can be installed on the ground.
- The upper and lower adjustable beams on an IFS06 can be moved up and down to fit for heights of RRUs.
- RRUs can be installed on an IFS06 only when the ambient temperature is higher than or equal to the lowest working temperature of the RRU and at least 5°C (41°F) lower than the highest working temperature of the RRU. In this scenario, the IFS06 supports at least three RRUs. When the ambient temperature is higher than or equal to the lowest working

temperature of the RRU and at least 10°C (50°F) lower than the highest working temperature of the RRU, the IFS06 supports a maximum of six RRUs.

NOTE

For details about the operating temperature of the RRU, see section "Technical Specifications of RRUs" in *3900 Series Base Station Technical Description*.

Specifications

Table 4-1 describes IFS06 specifications.

Table 4-1 IFS06 specifications

| Item | Specification |
|------------------------|--|
| Dimensions (H x W x D) | 1730 mm (79 in.) x 600 mm (23.62 in.) x 600 mm (23.62 in.) |
| Weight | 45 kg (99.23 lb) |

4.2 OCB

An Outdoor Cable Conversion Box (OCB) interconnects cables of different core diameters. Power cables shipped with RRUs cannot support long-distance power supply. Therefore, when power supply is far from the equipment, cables with large core diameters are used, and an OCB connects these cables and RRU power cables.

Application Scenario of an OCB

Figure 4-2 shows the application scenario of an OCB.

Figure 4-2 Application scenario of an OCB

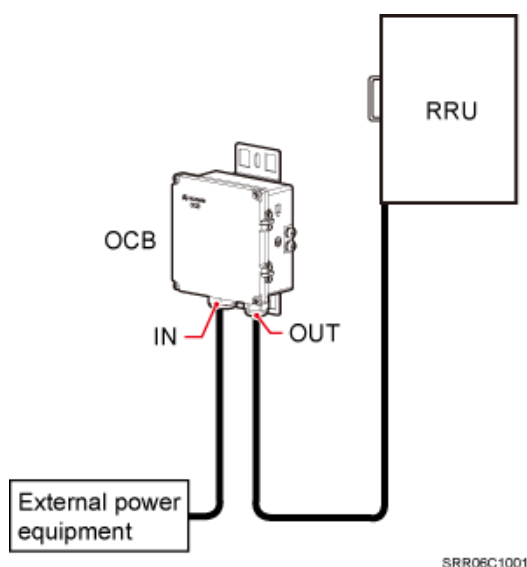

For details about the structure, functions, installation, and maintenance of an OCB, see the *OCB User Guide*.