

RRU5909&RRU5309&RRU5309w&RRU3959a Installation Guide

Contents

- 7.2.2 [RRU5909&RRU5309&RRU5309w&RRU3959a Installation Guide](#)
- 7.2.2.1 [Changes in RRU5909&RRU5309&RRU5309w&RRU3959a Installation Guide](#)
- 7.2.2.2 [Installation Preparations](#)
- 7.2.2.2.1 [Reference Documents](#)
- 7.2.2.2.2 [Tools and Instruments](#)
- 7.2.2.2.3 [Skills and Requirements for Onsite Personnel](#)
- 7.2.2.3 [Information About the Installation](#)
- 7.2.2.3.1 [RRU Exterior](#)
- 7.2.2.3.2 [RRU Ports](#)
- 7.2.2.3.3 [RRU Indicators](#)
- 7.2.2.3.4 [Installation Scenarios](#)
- 7.2.2.3.5 [Installation Clearance Requirements of an RRU](#)
- 7.2.2.3.5.1 [Clearance for a Single RRU](#)
- 7.2.2.3.5.2 [Clearance for Three or More RRUs](#)
- 7.2.2.3.5.3 [Installation Spacing Between RRUs](#)
- 7.2.2.4 [Unpacking the Equipment](#)
- 7.2.2.5 [Installation Process](#)
- 7.2.2.6 [Hoisting an RRU and Related Cables onto a Tower](#)
- 7.2.2.6.1 [Hoisting an RRU onto a Tower](#)
- 7.2.2.6.2 [Hoisting Optical Fibers onto a Tower](#)
- 7.2.2.6.3 [Hoisting Power Cables onto a Tower](#)
- 7.2.2.7 [Installing the RRU](#)
- 7.2.2.7.1 [Mounting Kits for an RRU](#)
- 7.2.2.7.2 [Installing the RRU on a Pole](#)
- 7.2.2.7.2.1 [Installing a Single RRU](#)
- 7.2.2.7.2.2 [Installing Two RRUs](#)
- 7.2.2.7.2.3 [Installing Three or More RRUs](#)
- 7.2.2.7.3 [Installing an RRU on U-steel](#)
- 7.2.2.7.4 [Installing an RRU on Angle Steel](#)
- 7.2.2.7.5 [Installing an RRU on a Wall](#)
- 7.2.2.7.6 [Installing an RRU on an IFS06](#)
- 7.2.2.8 [Installing RRU Cables](#)
- 7.2.2.8.1 [Cabling Requirements](#)
- 7.2.2.8.2 [RRU Cable Connections](#)
- 7.2.2.8.3 [Installing RRU Cables](#)
- 7.2.2.8.4 [RRU Cable List](#)
- 7.2.2.8.5 [Installing an RRU PGND Cable](#)
- 7.2.2.8.6 [Installing an RRU RF Jumper](#)
- 7.2.2.8.7 [Installing an RRU AISG Multi-Wire Cable and AISG Extension Cable](#)
- 7.2.2.8.8 [Opening the Cover Plate of an RRU Cabling Cavity](#)

- 7.2.2.8.9 [Installing a CPRI Optical Fiber](#)
- 7.2.2.8.10 [Installing an RRU power cable](#)
- 7.2.2.8.11 [Closing the Cover Plate of an RRU Cabling Cavity](#)
- 7.2.2.9 [Checking the RRU Hardware Installation](#)
- 7.2.2.10 [Powering On an RRU](#)
- 7.2.2.11 [Appendix](#)
- 7.2.2.11.1 [Adding a Female Fast Connector\(Pressfit Type\) to the RRU Power Cable on the RRU Side](#)

7.2.2

RRU5909&RRU5309&RRU5309w&RRU3959a Installation Guide

Purpose

This document describes the process of installing DC blade RRU5909&RRU5309&RRU5309w&RRU3959a(referred to as RRU in this document). RRU is short for remote radio unit.

Product Versions

The following table lists the product version related to this document for RRU5909&RRU3959a.

Product Name	Solution Version	Product Version
RRU5909&RRU3959a	<ul style="list-style-type: none"> • SRAN10.1 and later versions • GBSS17.1 and later versions • eRAN8.1 and later versions 	V100R010C10 and later versions

The following table lists the product version related to this document for RRU5309&RRU5309w.

Product Name	Solution Version	Product Version
RRU5309&RRU5309w	<ul style="list-style-type: none"> • SRAN11.1 and later versions • eRAN11.1 and later versions 	V100R011C10 and later versions

Intended Audience

This document is intended for:
Base station installation engineers

Organization

[Changes in RRU5909&RRU5309&RRU5309w&RRU3959a Installation Guide](#)

This section describes the changes in the *RRU5909&RRU5309&RRU5309w&RRU3959a Installation Guide*.

[Installation Preparations](#)

This chapter describes the reference documents, tools, and instruments that must be ready before the installation. In addition, it specifies the skills and prerequisites that installation engineers must have.

[Information About the Installation](#)

Before installing an RRU, you must be familiar with its exterior, ports, indicators, installation scenarios, and installation clearance requirements.

[Unpacking the Equipment](#)

This chapter describes how to unpack and check the delivered equipment to ensure that all the materials are included and intact.

[Installation Process](#)

The installation process involves installing an RRU and RRU cables, checking the RRU hardware installation, and powering on an RRU.

[Hoisting an RRU and Related Cables onto a Tower](#)

This section describes the procedure for hoisting an RRU and related cables onto a tower and the precautions that must be taken.

[Installing the RRU](#)

This chapter describes the procedure for installing the RRU. The procedure for installing the RRU varies depending on installation options.

[Installing RRU Cables](#)

This chapter describes the procedure for installing RRU cables.

[Checking the RRU Hardware Installation](#)

[Powering On an RRU](#)

After all the devices are installed, check the power-on status of an RRU.

[Appendix](#)

Huawei Proprietary and Confidential Copyright © Huawei Technologies Co., Ltd.

Huawei Proprietary and Confidential

Copyright © Huawei Technologies Co., Ltd.

[Next topic >](#)

7.2.2.1 Changes in RRU5909&RRU5309&RRU5309w&RRU3959 a Installation Guide

This section describes the changes in the *RRU5909&RRU5309&RRU5309w&RRU3959a Installation Guide*.

This is the ninth official release.

Compared with Issue 08 (2018-04-30), this issue does not include any new information.

Compared with Issue 08 (2018-04-30), this issue includes the following change.

Topic	Change Description
The whole document	Modified the figures showing the mounting kits for an RRU , which have been modified.

Compared with Issue 08 (2018-04-30), no information is deleted from this issue.

08 (2018-04-30)

This is the eighth official release.

Compared with Issue 07 (2018-03-20), this issue does not include any new information.

Compared with Issue 07 (2018-03-20), this issue includes the following change.

Topic	Change Description
Installation Scenarios	Added the installation restriction for RRU5309w external antennas.

Compared with Issue 07 (2018-03-20), no information is deleted from this issue.

07 (2018-03-20)

This is the seventh official release.

Compared with Issue 06 (2018-01-30), this issue does not include any new information.

Compared with Issue 06 (2018-01-30), this issue includes the following change.

Topic	Change Description
RRU Cable Connections	Optimized the descriptions in some sections. No technical change is involved.

Compared with Issue 06 (2018-01-30), no information is deleted from this issue.

06 (2018-01-30)

This is the sixth official release.

Compared with Issue 05 (2017-09-20), this issue does not include any new information.

Compared with Issue 05 (2017-09-20), this issue includes the following change.

Topic	Change Description
The whole document	Added information about the RRU3959a.

Compared with Issue 05 (2017-09-20), no information is deleted from this issue.

05 (2017-09-20)

This is the fifth official release.

Compared with Issue 04 (2017-08-30), this issue does not include any new information.

Compared with Issue 04 (2017-08-30), this issue includes the following change.

Topic	Change Description
RRU5909&RRU5309&RRU5309w&RRU3959a Installation Guide	Updated the required product versions and added support of the RRU by the DBS5900.

Compared with Issue 04 (2017-08-30), no information is deleted from this issue.

04 (2017-08-30)

This is the fourth official release.

Compared with Issue 03 (2017-06-30), this issue does not include any new information.

Compared with Issue 03 (2017-06-30), this issue includes the following change.

Topic	Change Description
The whole document	Added information about the RRU5309 and RRU5309w.

Compared with Issue 03 (2017-06-30), no information is deleted from this issue.

03 (2017-06-30)

This is the third official release.

Compared with Issue 02 (2017-06-05), this issue does not include any new information.

Compared with Issue 02 (2017-06-05), this issue includes the following change.

Topic	Change Description
Hoisting an RRU onto a Tower	Added descriptions of the OPM50M(Ver.B).

Compared with Issue 02 (2017-06-05), no information is deleted from this issue.

02 (2017-06-05)

This is the second official release.

Compared with Issue 01 (2017-05-20), this issue does not include any new information.

Compared with Issue 01 (2017-05-20), this issue includes the following change.

Topic	Change Description
Installing a CPRI Optical Fiber	Added the following precaution for adding an optical module: Before connecting the optical fiber to the optical module, keep the dustproof cap in the port of the optical module.

Compared with Issue 01 (2017-05-20), no information is deleted from this issue.

01 (2017-05-20)

This is the first official release.

Compared with Draft C (2017-04-20), this issue does not include any new information.

Compared with Draft C (2017-04-20), this issue does not include any changes.

No information in Draft C (2017-04-20) is deleted from this issue.

Draft C (2017-04-20)

This is a draft.

Compared with Draft B (2017-03-10), this issue includes the following change.

Topic	Change Description
RRU5909&RRU5309&RRU5309w&RRU3959a Installation Guide	Updated the RRU solution version and product version.

Compared with Draft B (2017-03-10), this issue does not include any new information and no information is deleted from this issue.

Draft B (2017-03-10)

This is a draft.

Compared with Draft A (2017-01-20), this issue includes the following changes.

Topic	Change Description
Installation Scenarios Installation Clearance Requirements of an RRU Installing the RRU Installing RRU Cables	Optimized figures related to RRU exterior in these sections.

Compared with Draft A (2017-01-20), this issue does not include any new information and no information is deleted from this issue.

Draft A (2017-01-20)

This is a draft.

Huawei Proprietary and Confidential Copyright © Huawei Technologies Co., Ltd.
Huawei Proprietary and Confidential
Copyright © Huawei Technologies Co., Ltd.
[Next topic >](#)

7.2.2.2 Installation Preparations

This chapter describes the reference documents, tools, and instruments that must be ready before the installation. In addition, it specifies the skills and prerequisites that installation engineers must have.

[Reference Documents](#)

Before the installation, you must be familiar with reference documents.

[Tools and Instruments](#)

This section describes the tools and instruments that must be prepared before the remote radio unit (RRU) installation.

[Skills and Requirements for Onsite Personnel](#)

Onsite personnel must be qualified and trained. Before performing any operation, onsite personnel must be familiar with correct operation methods and safety precautions.

Huawei Proprietary and Confidential Copyright © Huawei Technologies Co., Ltd.
Huawei Proprietary and Confidential
Copyright © Huawei Technologies Co., Ltd.
< [Previous topic](#) [Next topic](#) >

7.2.2.2.1 Reference Documents

Before the installation, you must be familiar with reference documents.

The following reference documents are required during [RRU](#) installation:

- *Safety Information*
- *RRU5909&RRU5309&RRU5309w&RRU3959a Hardware Description*
- *DBS3900 Installation Guide* or *DBS5900 Installation Guide*



NOTE:











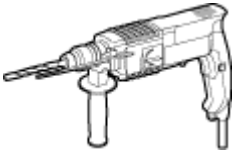
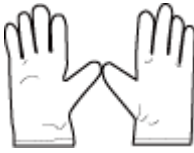

For details about RRU auxiliary devices, see "RRU Auxiliary Devices" in the corresponding RRU hardware description.

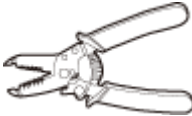

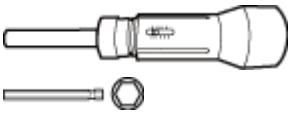

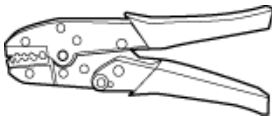
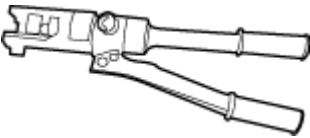

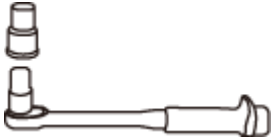



Parent Topic: [Installation Preparations](#)

Huawei Proprietary and Confidential Copyright © Huawei Technologies Co., Ltd.

7.2.2.2 Tools and Instruments

This section describes the tools and instruments that must be prepared before the remote radio unit (RRU) installation.

<p>Hammer drill (ϕ 12 bit, a ϕ 14 bit)</p> 	<p>ESD gloves</p> 	<p>Vacuum cleaner</p> 
<p>Rubber mallet</p> 	<p>Phillips screwdriver (M3 to M6)</p> 	<p>Flat-head screwdriver (M3 to M6)</p> 
<p>Wire stripper</p> 	<p>Cable cutter</p> 	<p>Diagonal pliers</p> 
<p>Torque screwdriver</p>  <p>5 mm (0.2 in.)</p>  <p>(M3 to M6)</p>  <p>(M3 to M6)</p>	<p>Power cable crimping tool</p> 	<p>Hydraulic pliers</p> 
<p>Adjustable wrench (open mouth \geq 32 mm [1.26 in.])</p>  <p>Torque wrench</p>  <p>Open mouth: 16 mm (0.63 in.), 17 mm (0.67 in.), 19 mm (0.75 in.), 21 mm (0.83 in.)</p>	<p>Torque socket</p>  <p>(M8, M10)</p>	<p>Heat gun</p> 

<p>in.), 22 mm (0.87 in.), and 32 mm (1.26 in.)</p> <p>Combination wrench</p>  <p>Open mouth: 16 mm (0.63 in.), 17 mm (0.67 in.), 19 mm (0.75 in.), 21 mm (0.83 in.), 22 mm (0.87 in.), and 32 mm (1.26 in.)</p>		
<p>Multimeter</p> 	<p>Marker (diameter ≤ 10 mm [0.39 in.])</p> 	<p>Measuring tape</p> 
<p>Inner hexagon wrench</p>  <p>5 mm (0.2 in.)</p>	<p>Fixed pulley (weight-bearing capacity > 500 kg or 1102.5 lb)</p> 	<p>Lifting sling</p> 
<p>Utility knife</p> 	<p>Level</p> 	<p>Protective gloves</p> 

Parent Topic: [Installation Preparations](#)

Huawei Proprietary and Confidential Copyright © Huawei Technologies Co., Ltd.

Huawei Proprietary and Confidential

Copyright © Huawei Technologies Co., Ltd.

[< Previous topic](#) [Next topic >](#)

7.2.2.2.3 Skills and Requirements for Onsite Personnel

Onsite personnel must be qualified and trained. Before performing any operation, onsite personnel must be familiar with correct operation methods and safety precautions.

Before the installation, pay attention to the following items:

- The customer's technical engineers must be trained by Huawei and be familiar with the proper installation and operation methods.
- The number of onsite personnel depends on the engineering schedule and installation environment. Generally, only three to five onsite personnel are necessary.

Parent Topic: [Installation Preparations](#)

Huawei Proprietary and Confidential Copyright © Huawei Technologies Co., Ltd.
Huawei Proprietary and Confidential
Copyright © Huawei Technologies Co., Ltd.
[< Previous topic](#)

7.2.2.3 Information About the Installation

Before installing an [RRU](#), you must be familiar with its exterior, ports, indicators, installation scenarios, and installation clearance requirements.

[RRU Exterior](#)

This section describes the exterior and dimensions of an RRU.

[RRU Ports](#)

This section describes ports on the RRU panels. An RRU has a bottom panel, cabling cavity panel, and indicator panel.

[RRU Indicators](#)

This section describes six indicators on an RRU. They indicate the running status of the RRU.

[Installation Scenarios](#)

An RRU can be installed on a pole, U-steel, angle steel, wall, or IFS06. Installation scenarios must meet heat-dissipation and waterproofing requirements of the RRU.

[Installation Clearance Requirements of an RRU](#)

This section describes the requirements for the installation clearance of a single RRU and multiple RRUs and the requirements for the installation spacing between RRUs.

Huawei Proprietary and Confidential Copyright © Huawei Technologies Co., Ltd.
Huawei Proprietary and Confidential
Copyright © Huawei Technologies Co., Ltd.
[< Previous topic](#) [Next topic >](#)

7.2.2.3.1 RRU Exterior

This section describes the exterior and dimensions of an [RRU](#).

[Figure 1](#) shows the exterior of an RRU.

Figure 1 RRU exterior

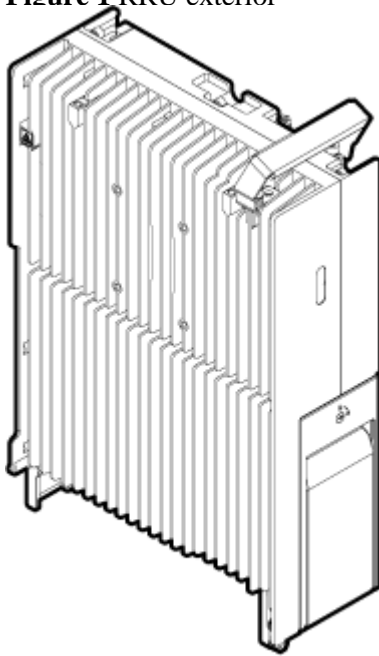

PARA1C001

[Figure 2](#) shows RRU dimensions.

Figure 2 RRU dimensions

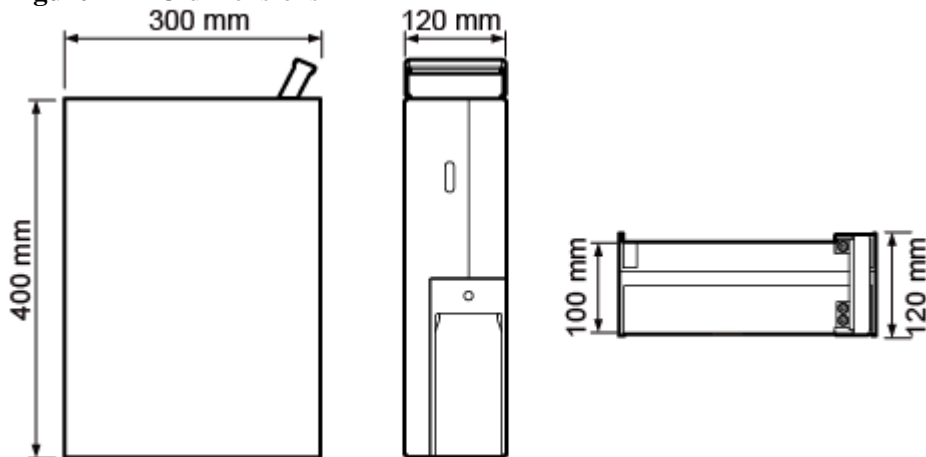

PAR96C005

You can obtain the RRU name, RRU frequency band and power supply information from the nameplate on the cover plate. [Figure 3](#) shows the positions of the nameplate on the RRU.

 **NOTE:**

The actual nameplate may differ from what is shown in the figure.

Figure 3 Positions of the nameplate

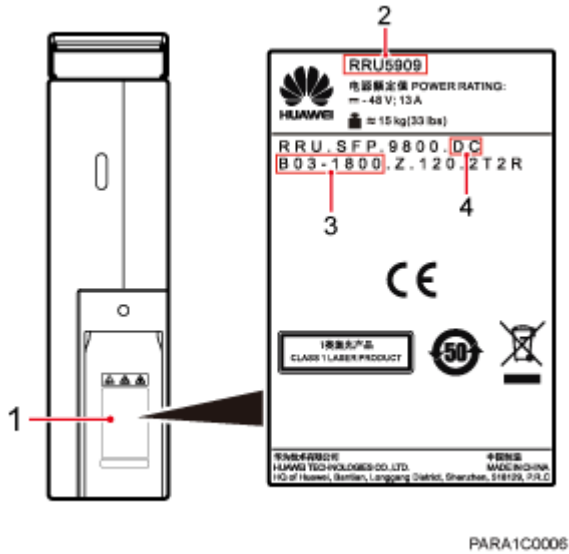

- (1) Nameplate (2) Module name (3) Frequency band (4) Power supply type

Parent Topic: [RRU Introduction](#)

Huawei Proprietary and Confidential Copyright © Huawei Technologies Co., Ltd.

Huawei Proprietary and Confidential

Copyright © Huawei Technologies Co., Ltd.

[Next topic >](#)

7.2.2.3.2 RRU Ports

This section describes ports on the [RRU](#) panels. An RRU has a bottom panel, cabling cavity panel, and indicator panel.

[Figure 1](#) shows the ports on the RRU panels.

Figure 1 Ports on the RRU panels

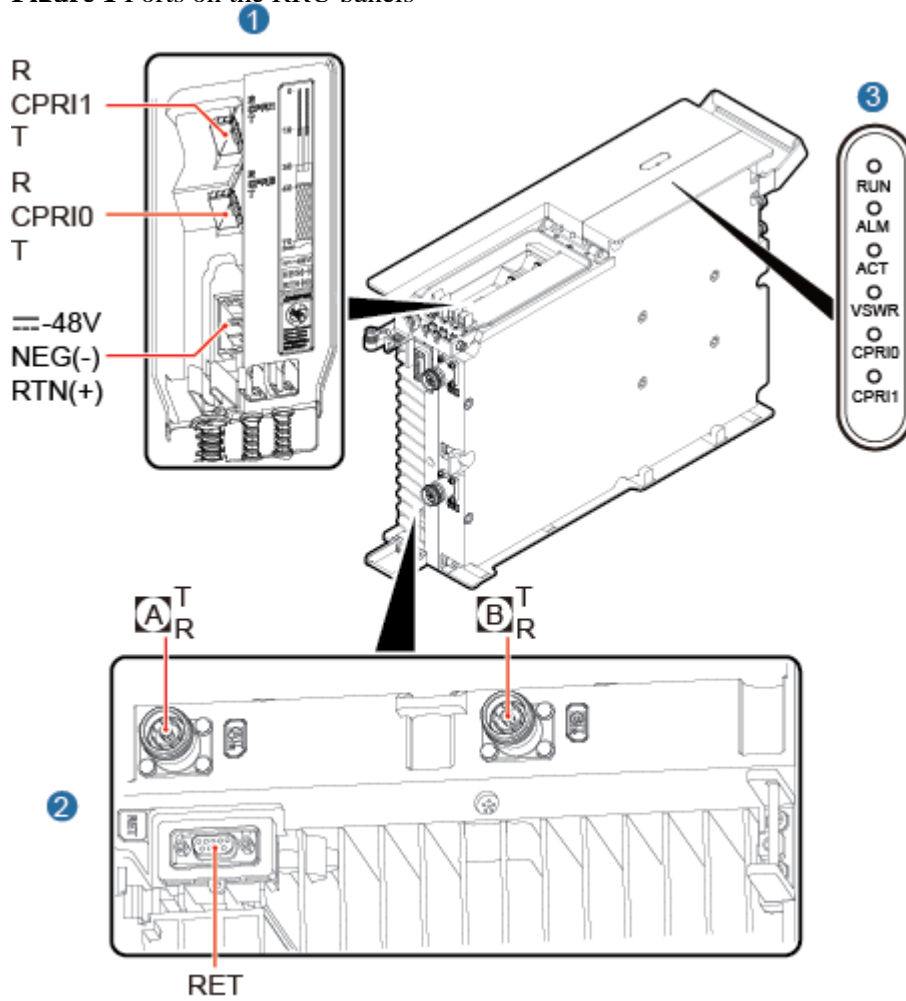

PARA1C0002

Table 1 Ports and indicators on the RRU panels

Item	Silkscreen	Remarks
(1) Ports in the cabling cavity	RTN(+)	Power supply socket, For details about RRU power cable appearance and specifications, see RRU Power Cable .
	NEG(-)	
	CPRI0	Optical/electrical port 0, connected to the BBU or an upper-level RRU
	CPRI1	Optical/electrical port 1, connected to a lower-level RRU or the BBU
(2) Bottom ports	A T/R	TX/RX port A (4.3-10 female connector), supporting RET signal transmission
	B T/R	TX/RX port B (4.3-10 female connector)

Table 1 Ports and indicators on the RRU panels

Item	Silkscreen	Remarks
	RET	Communication port for the RET antenna, supporting RET signal transmission
(3) Indicator	RUN	For details, see RRU Indicators .
	ALM	
	ACT	
	VSWR	
	CPRI0	
	CPRI1	

**NOTE:**

- The port for transmitting RET signals is determined by the software.
- Connect the **CPRI0** port to the BBU by default in the single-mode scenario.

Parent Topic: [RRU Introduction](#)

Huawei Proprietary and Confidential Copyright © Huawei Technologies Co., Ltd.

Huawei Proprietary and Confidential

Copyright © Huawei Technologies Co., Ltd.

[< Previous topic](#) [Next topic >](#)

7.2.2.3.3 RRU Indicators

This section describes six indicators on an [RRU](#). They indicate the running status of the RRU.

For detailed positions of RRU indicators, see [RRU Ports](#).

[Table 1](#) describes RRU indicators.

Table 1 RRU Indicators

Indicator	Color	Status	Meaning
RUN	Green	Steady on	The power input is available, but the board is faulty.
		Steady off	No power input is available, or the board is faulty.
		Blinking (on for 1s and off for 1s)	The board is running properly.

Table 1 RRU Indicators

Indicator	Color	Status	Meaning
		Blinking (on for 0.125s and off for 0.125s)	The board software is being loaded, or the board is not working.
ALM	Red	Steady on	Alarms are generated, and the module must be replaced.
		Blinking (on for 1s and off for 1s)	Alarms are generated. The alarms may be caused by faults on the related board or ports. Therefore, you need to locate the fault before deciding whether to replace the module.
		Steady off	No alarms are generated.
ACT	Green	Steady on	The board is working properly when TX channels are enabled or software is being loaded to a board that is not started.
		Blinking (on for 1s and off for 1s)	The board is running with TX channels disabled.
VSWR	Red	Steady off	No voltage standing wave ratio (VSWR) alarm is generated.
		Blinking (on for 1s and off for 1s)	VSWR alarms are generated on the B T/R port.
		Steady on	VSWR alarms are generated on the A T/R port.
		Blinking (on for 0.125s and off for 0.125s)	VSWR alarms are generated on the A T/R and B T/R ports.
CPRI0	Red and green	Steady green	The CPRI link is running properly.
		Steady red	An optical module fails to receive or transmit signals possibly because the optical module is faulty or the optical fiber is broken.
		Blinking red (on for 1s and off for 1s)	The CPRI link is out of lock because of faults on the mutual lock of dual-mode clock sources or mismatched data rates on CPRI ports.
		Steady off	The optical module cannot be detected or is powered off.
CPRI1		Steady green	The CPRI link is running properly.

Table 1 RRU Indicators

Indicator	Color	Status	Meaning
	Red and green	Steady red	An optical module fails to receive or transmit signals possibly because the optical module is faulty or the optical fiber is broken.
		Blinking red (on for 1s and off for 1s)	The CPRI link is out of lock because of faults on the mutual lock of dual-mode clock sources or mismatched data rates on CPRI ports.
		Steady off	The optical module cannot be detected or is powered off.

 **NOTE:**

VSWR indicators on RRUs providing one or more than two TX channels have two types of status:

- Steady off: No VSWR alarm is generated.
- Steady on: VSWR alarms are generated on one or more ports.

Parent Topic: [RRU Introduction](#)

Huawei Proprietary and Confidential Copyright © Huawei Technologies Co., Ltd.

Huawei Proprietary and Confidential

Copyright © Huawei Technologies Co., Ltd.

[< Previous topic](#) [Next topic >](#)

7.2.2.3.4 Installation Scenarios

An **RRU** can be installed on a pole, U-steel, angle steel, wall, or IFS06. Installation scenarios must meet heat-dissipation and waterproofing requirements of the RRU.

- [Requirements for the Installation Scenarios](#)
- [Installing an RRU on a Pole](#)
- [Installing an RRU on U-Steel](#)
- [Installing an RRU on Angle Steel](#)
- [Installing an RRU on a Wall](#)
- [Installing an RRU on an IFS06](#)

Requirements for the Installation Scenarios

 **NOTICE:**

RRU is a professional communications equipment and cannot be installed in areas which are accessible to people. The installation scenarios involve the related security features. For details about specific requirements and precautions, see *Safety Information*.

Application scenarios:

To ensure proper heat dissipation of the RRU, the following requirements must be met:

- The RRU cannot be installed in an enclosed cabinet without a cooling system.
 - The RRU cannot be installed in an enclosed camouflage box.
 - The RRU cannot be installed in an enclosed equipment room without a cooling system.
 - When multiple RRUs are installed in centralized mode, the minimum clearance requirements must be met. For details about the minimum clearance requirements, see [Clearance for Three or More RRUs](#) and [Installation Spacing Between RRUs](#).
-

⚠NOTICE:

If the RRU is inappropriately installed, heat dissipation of the RRU deteriorates and the RRU may not work properly, as shown in [Figure 1](#).

Figure 1 Inappropriately installed RRU



SRE00C0005

Installation restrictions:

- The specifications of installation supports described in this document are based only on the exterior and dimensions of the mounting kits. Before installing equipment, assess the strength and reliability of the installation support to determine whether it can bear the weight of the equipment.
- To ensure the heat dissipation of the RRU and waterproofing of the ports at the bottom of the RRU, the vertical deviation angle of an RRU must be less than or equal to 10 degrees, as shown in [Figure 2](#).
- On a tower, an RRU can be installed on a pole, angle steel, or U-steel. The side-mounted installation mode (one side instead of the rear of an RRU is mounted on the support) is recommended for RRUs on the main pole secured on a tower. This installation mode allows the

RRU stacked installation. When the horizontal distance between the main and auxiliary poles on a tower is greater than or equal to 810 mm (23.62 in.), the side-mounted mode is recommended for installing RRUs on the auxiliary pole to meet the minimum clearance requirements. Otherwise, the standard mode is recommended for installing RRUs on the auxiliary pole.

- RRU stacked installation is not allowed in indoor scenarios.
- RRU stacked installation is allowed only when installed on one or more poles in outdoor scenarios, and a maximum of three RRUs can be stacked installation.
- The periphery of RRU5309w external antennas should avoid metal shielding (such as wirelines of the cable tower, metal fence, ground bar, and billboard).

Figure 2 Requirements for the vertical deviation angle of an RRU

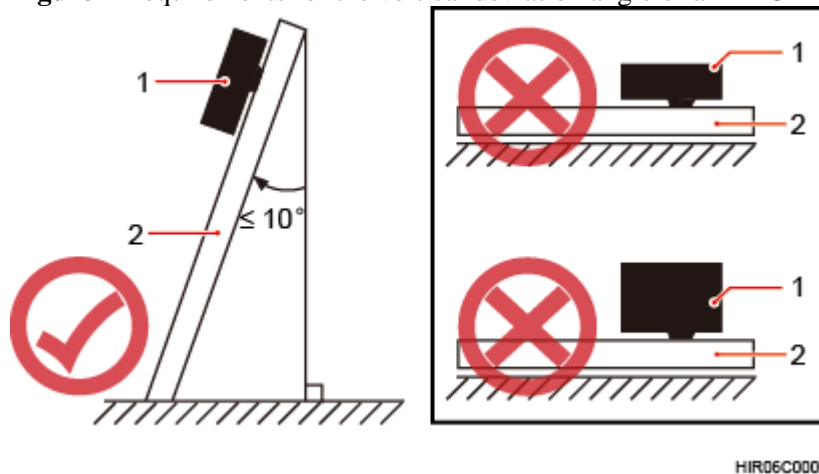

HIR06C0002

- (1) RRU (2) Installation support (pole, U-steel, angle steel, or wall)

NOTE:

- When the operator faces the RRU whose handle and cabling cavity are on the right-hand side, the side facing the operator is the front of the RRU, and the other side is the back of the RRU.
- Standard installation: RRU mounting kits are installed on the back of an RRU.
- Reverse installation: RRU mounting kits are installed on the front of an RRU.
- Side-mounted installation: RRU mounting kits are installed on the side face (not the side face of the maintenance cavity) of an RRU.
- Stacked installation: Two or more RRUs are installed next to each other at the same level by stacking multiple RRU mounting kits.

Installing an RRU on a Pole

[Figure 3](#) shows the diameter of a pole for installing an RRU.

Figure 3 Diameter of a pole

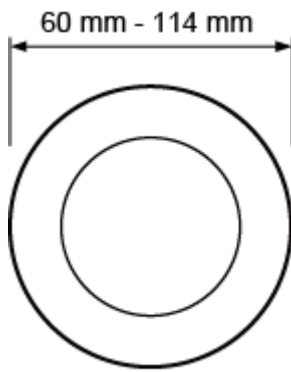

HIR06C0039

⚠ NOTICE:

- The diameter of a pole for installing an RRU ranges from 60 mm (2.36 in.) to 114 mm (4.49 in.). The recommended diameter is 80 mm (3.15 in.).
 - The recommended thickness of the pole wall is 3.5 mm (0.14 in.) or above.
 - When RRUs are installed on a pole, the side-mounted installation is recommended. A maximum of three RRUs can be installed on a pole with the diameter ranging from 60 mm (2.36 in.) to 76 mm (2.99 in.).
 - Only a pole whose diameter ranges from 76 mm (2.99 in.) to 114 mm (4.49 in.) supports more than three RRUs.
-

[Figure 4](#) shows a single RRU installed on a pole.

Figure 4 A single RRU installation on a pole

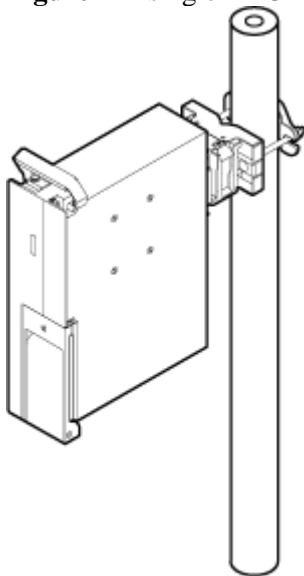

SRRA7C0010

[Figure 5](#) shows two RRUs installed on a pole.

Figure 5 shows an RRU installed on a pole

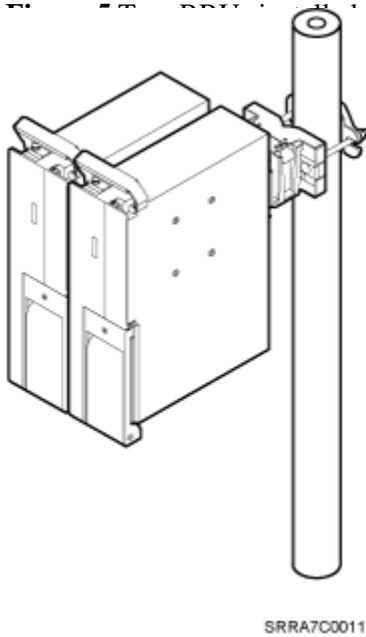

SRRRA7C0011

[Figure 6](#), [Figure 7](#), and [Figure 8](#) show multiple RRUs installed on a pole.

Figure 6 Three RRUs installed on an IFS06

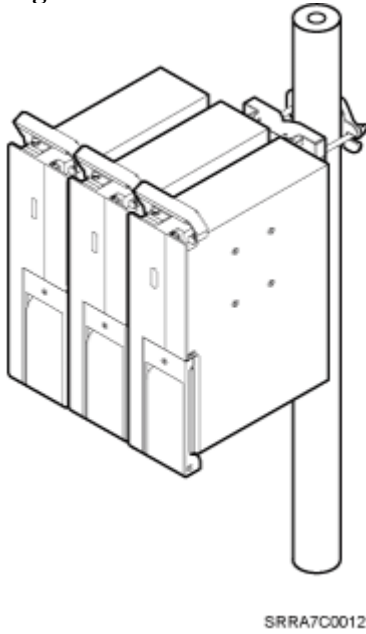

SRRRA7C0012

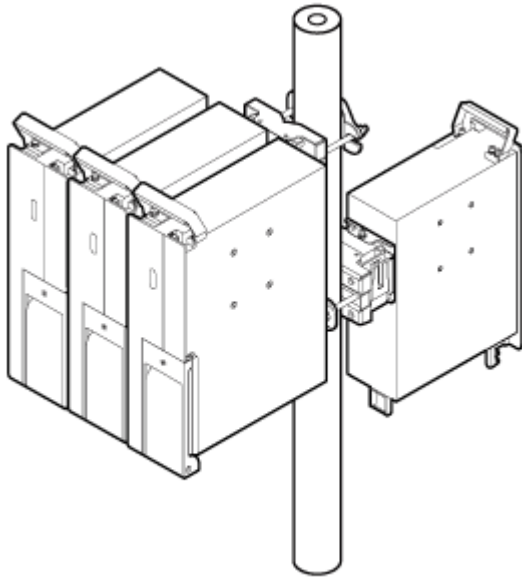

SRRA2C0013

Figure 8 Six RRUs installed on an IFS06

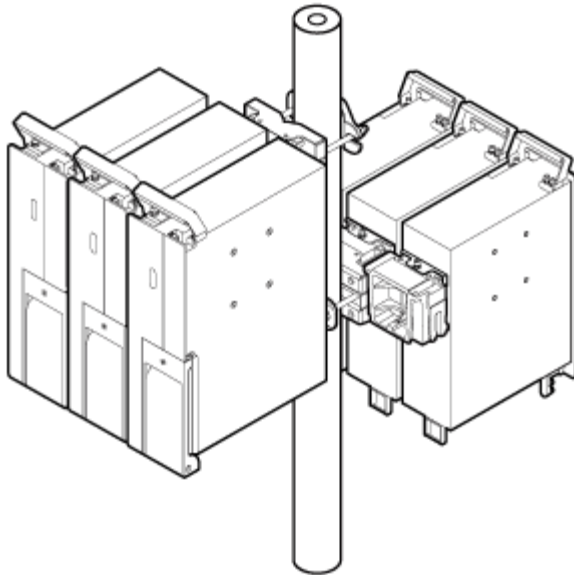

SRRA7C0014

Installing an RRU on U-Steel

[Figure 9](#) shows U-steel specifications.

Figure 9 U-steel specifications

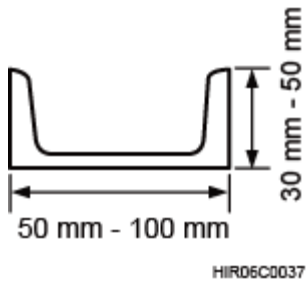

⚠ NOTICE:

U-steel supports only the standard or reverse installation of a single RRU.

[Figure 10](#) shows an RRU installed on U-steel.

Figure 10 RRU installed on U-steel

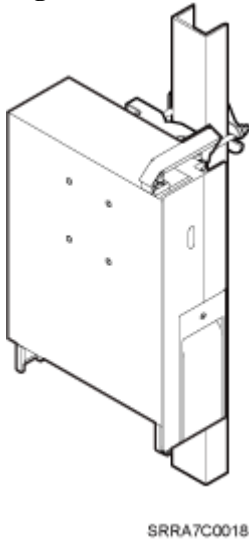

Installing an RRU on Angle Steel

[Figure 11](#) shows angle steel specifications.

Figure 11 Angle steel specifications

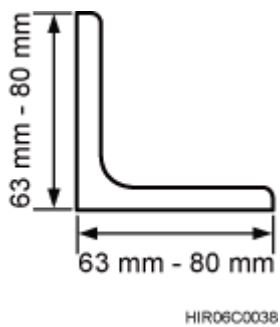

⚠NOTICE:

Angle steel supports only the standard or reverse installation of a single RRU.

[Figure 12](#) shows an RRU installed on angle steel.

Figure 12 RRU installed on angle steel

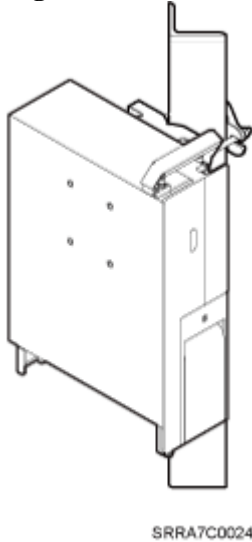

Installing an RRU on a Wall

The wall for installing RRUs must meet the following requirements:

- For each RRU, the wall must be able to bear a weight four times heavier than the RRU's weight and the bolts' pulling force of 1.25 kN (281.25 lbf) vertical to the wall.
- Expansion bolts must be tightened to 30 N·m (265.52 lbf·in.) to ensure that the bolts work properly and the wall remains intact.

⚠NOTICE:

- The standard installation is recommended for RRUs installed on a wall.
 - When RRUs are installed on a wall in side-mounted mode, RRU stacked installation is not allowed, as shown in [Figure 13](#).
-

Figure 13 Correct installation of RRUs installed on a wall in side-mounted mode

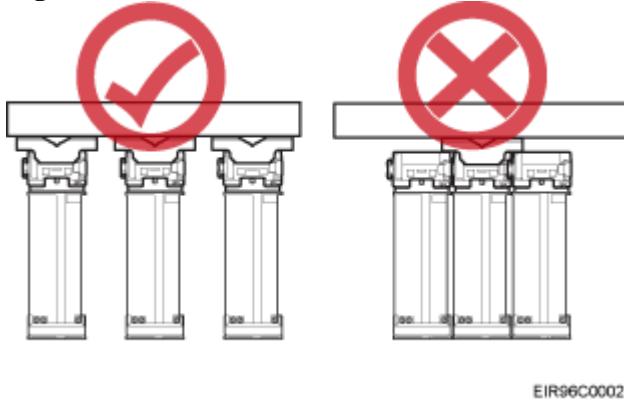

[Figure 14](#) shows an RRU installed on a wall.

Figure 14 RRU installed on a wall

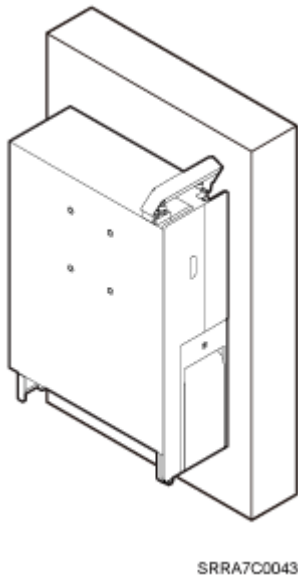

Installing an RRU on an IFS06

- The upper and lower adjustable beams on an IFS06 can be moved up and down to fit for heights of RRUs.
- The IFS06 supports at least three RRUs when the ambient temperature is higher than or equal to the lowest operating temperature of the RRUs and at least 5°C (41°F) lower than the highest operating temperature of the RRUs. The IFS06 supports a maximum of six RRUs when the ambient temperature is higher than or equal to the lowest operating temperature of the RRUs and at least 10°C (50°F) lower than the highest operating temperature of the RRUs.

 **NOTE:**

For details about the operating temperature of the RRUs, see section "Technical Specifications of RRUs" in *Base Station Technical Description*.

⚠ NOTICE:

RRUs cannot be stacked when the RRUs are installed on an IFS06, as shown in [Figure 15](#).

Figure 15 Correct installation of RRUs installed on an IFS06

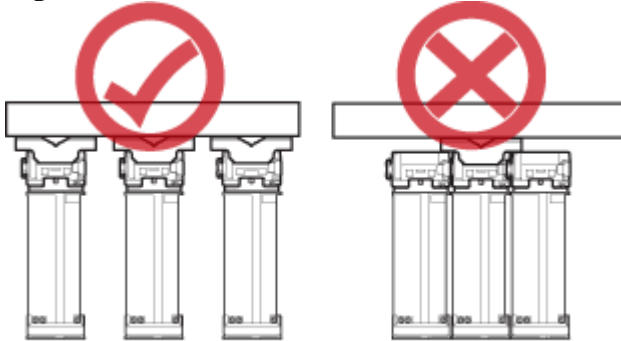

EIR96C0002

[Figure 16](#) and [Figure 17](#) show RRUs installed on an IFS06.

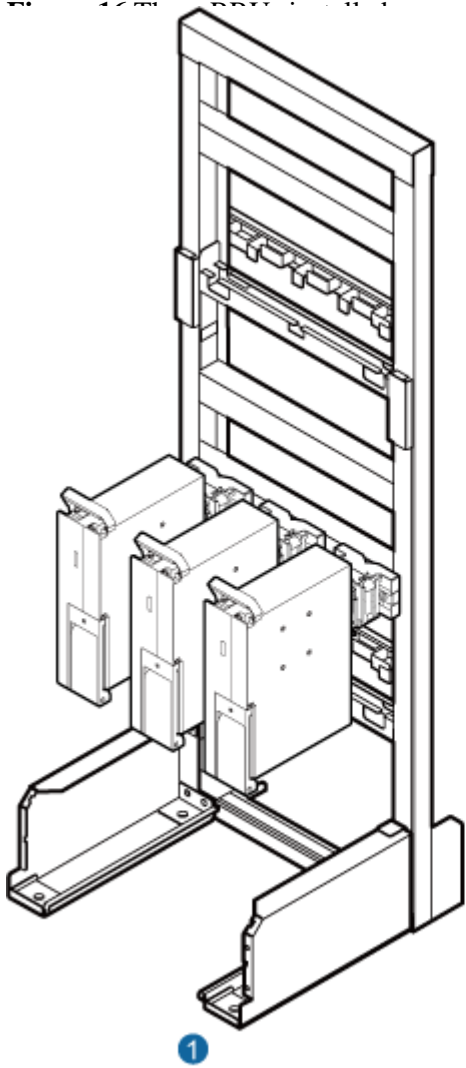

(1) Height-restricted scenario

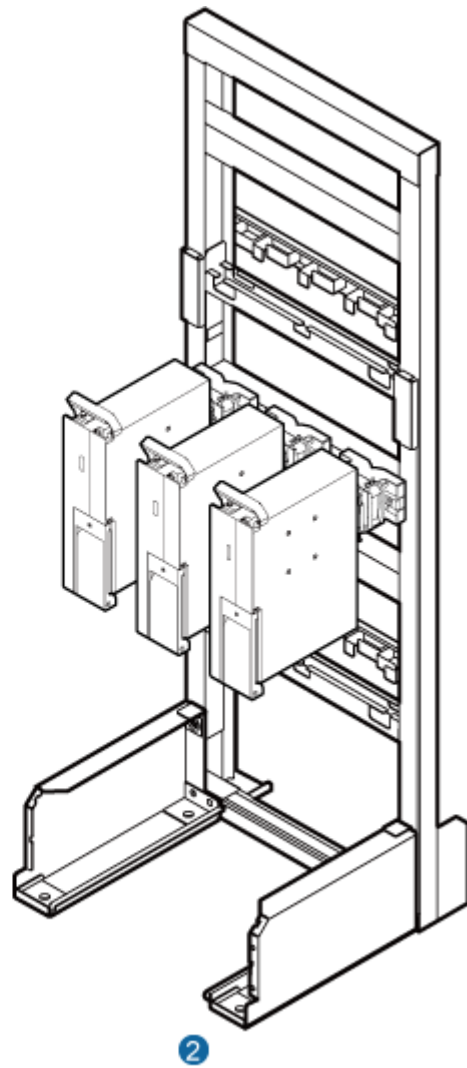

(2) Height-unrestricted scenario

PARA7C0008

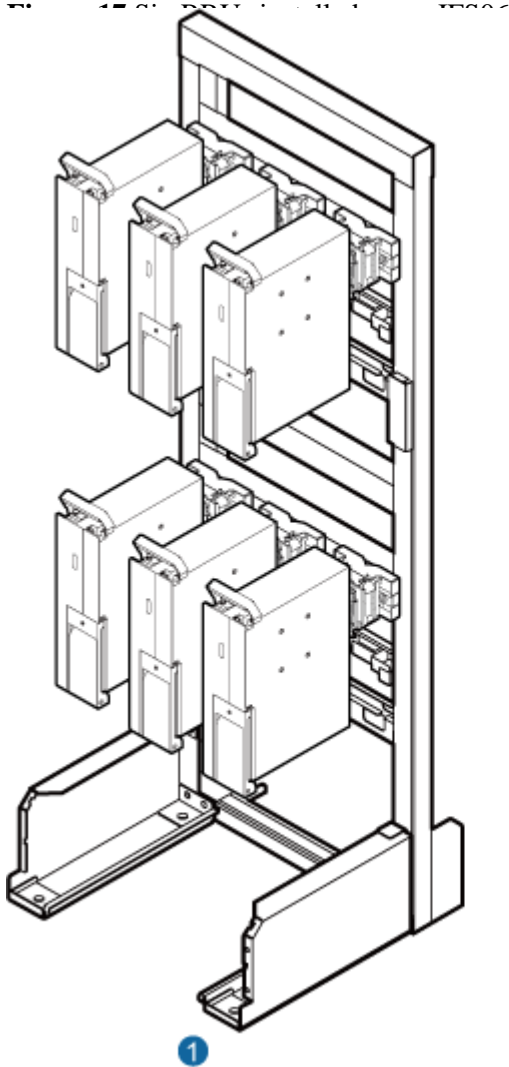

(1) Height-restricted scenario

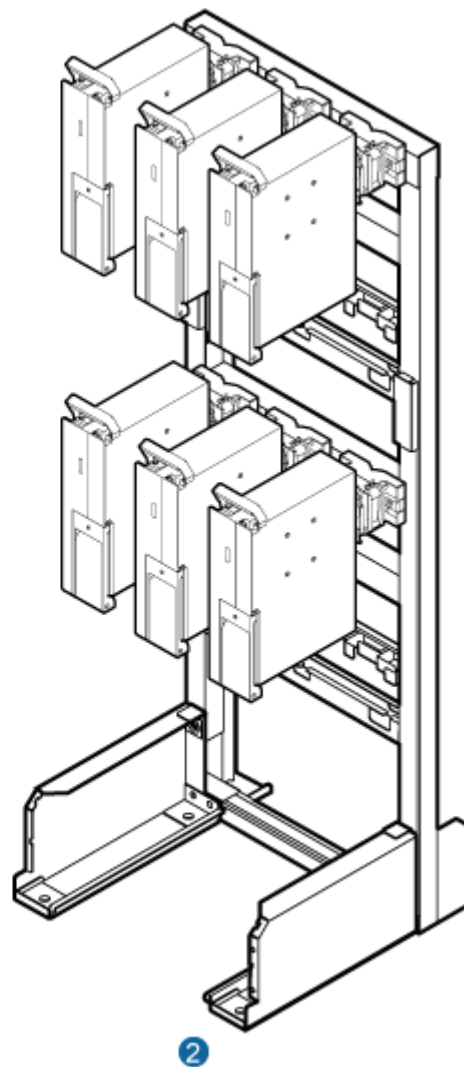

(2) Height-unrestricted scenario

PARA7C0009

Parent Topic: [Information About the Installation](#)

Huawei Proprietary and Confidential Copyright © Huawei Technologies Co., Ltd.

Huawei Proprietary and Confidential

Copyright © Huawei Technologies Co., Ltd.

[< Previous topic](#) [Next topic >](#)

7.2.2.3.5 Installation Clearance Requirements of an RRU

This section describes the requirements for the installation clearance of a single [RRU](#) and multiple RRUs and the requirements for the installation spacing between RRUs.

[Clearance for a Single RRU](#)

This section describes the recommended and minimum clearances for a single RRU.

[Clearance for Three or More RRUs](#)

This section describes the recommended and minimum clearances for three or more RRUs.

[Installation Spacing Between RRUs](#)

This section describes the horizontal and vertical spacing between RRUs.

Parent Topic: [Information About the Installation](#)

Huawei Proprietary and Confidential Copyright © Huawei Technologies Co., Ltd.

Huawei Proprietary and Confidential

Copyright © Huawei Technologies Co., Ltd.

[< Previous topic](#)

7.2.2.3.5.1 Clearance for a Single RRU

This section describes the recommended and minimum clearances for a single [RRU](#).

NOTICE:

If an RRU is installed on the bitumen ground, the RRU must be at least 500 mm (700 mm or more is recommended) away from the bitumen ground. The following describes the space requirements for installing a single RRU on the non-bitumen ground.

NOTE:

- The recommended clearances ensure normal running and provide appropriate space for operation and maintenance (O&M). If the installation space is sufficient, leave the recommended clearances after installing the equipment.
 - The minimum clearance ensures normal running and heat dissipation, but O&M activities such as checking indicator status and opening the cabling cavity cannot be properly conducted. If the installation space is restricted, leave the minimum clearance after installing the equipment.
-

- [Clearance for a Single RRU in Side-Mounted Mode](#)
- [Clearance for a Single RRU in Standard or Reverse Mode](#)
- [Clearance for a Single Tower-Mounted RRU](#)

Clearance for a Single RRU in Side-Mounted Mode

[Figure 1](#) shows the clearance for a single RRU in side-mounted mode.

Figure 1 Clearance for a single RRU in side-mounted mode
Recommended Clearances

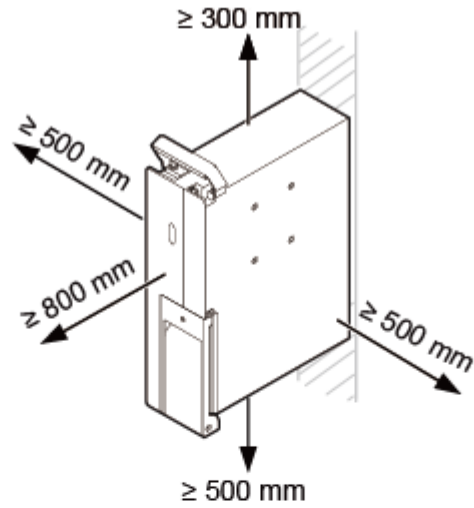

Minimum Clearances

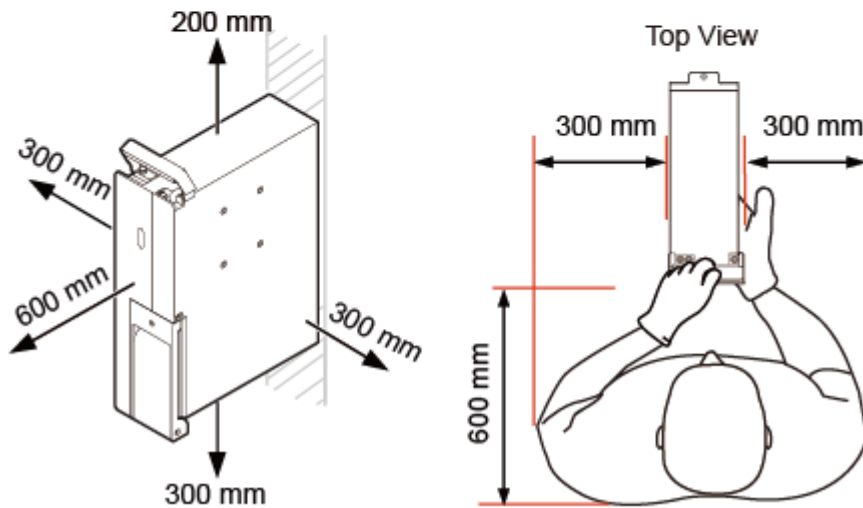

SRR A7C0052

Clearance for a Single RRU in Standard or Reverse Mode

[Figure 2](#) shows the clearance for a single RRU in standard or reverse mode.

Figure 2 Clearance for a single RRU in standard or reverse mode
Recommended Clearances

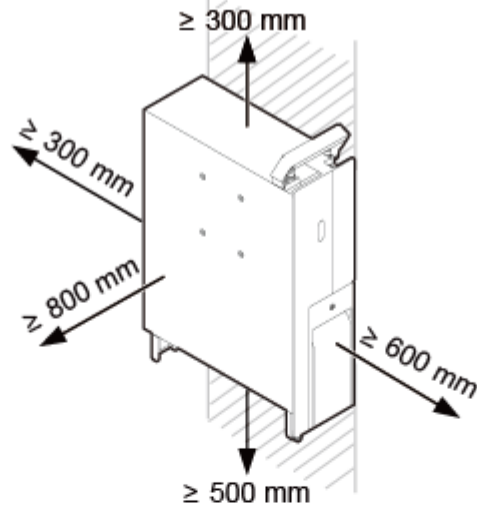

Minimum Clearances

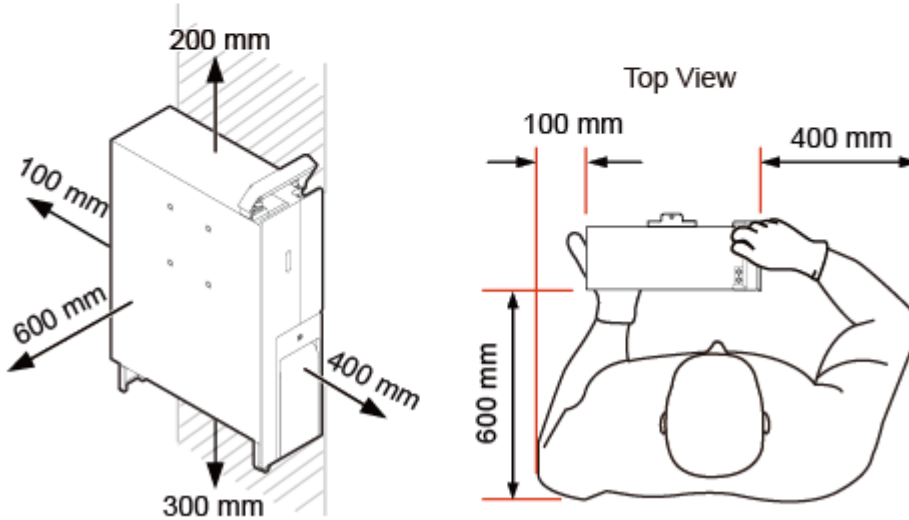

SRRA7C0051

Clearance for a Single Tower-Mounted RRU

[Figure 3](#) and [Figure 4](#) show the minimum clearances for a single RRU in side-mounted mode and standard or reverse mode on a tower.

Figure 3 Minimum clearance for a single RRU in side-mounted mode on a tower

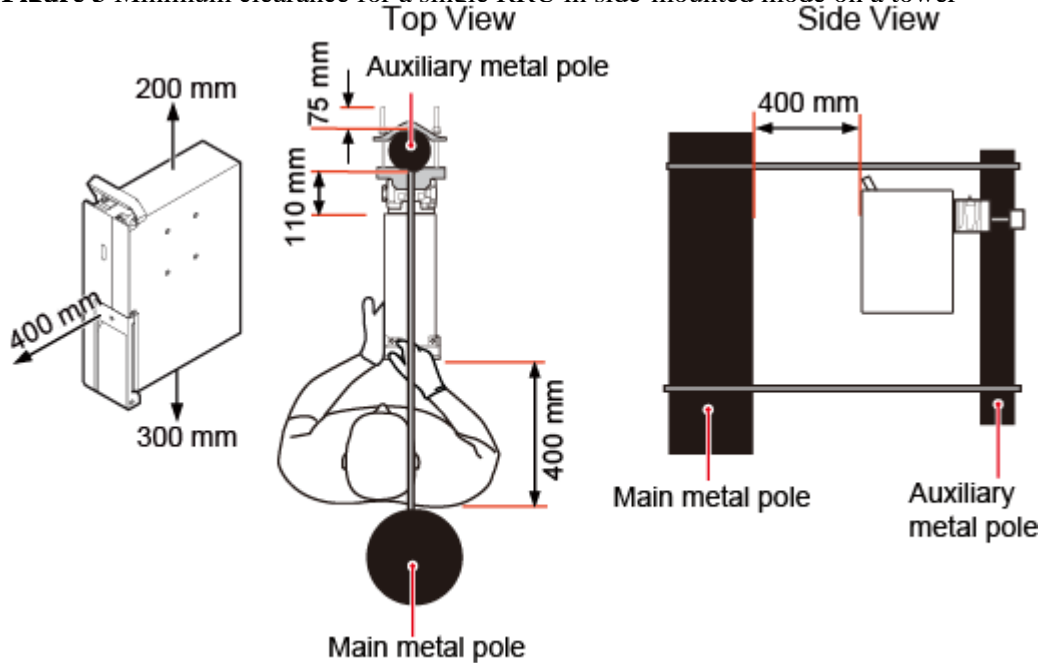

SRRA7C0027

Figure 4 Minimum clearance for a single RRU in standard or reverse mode on a tower

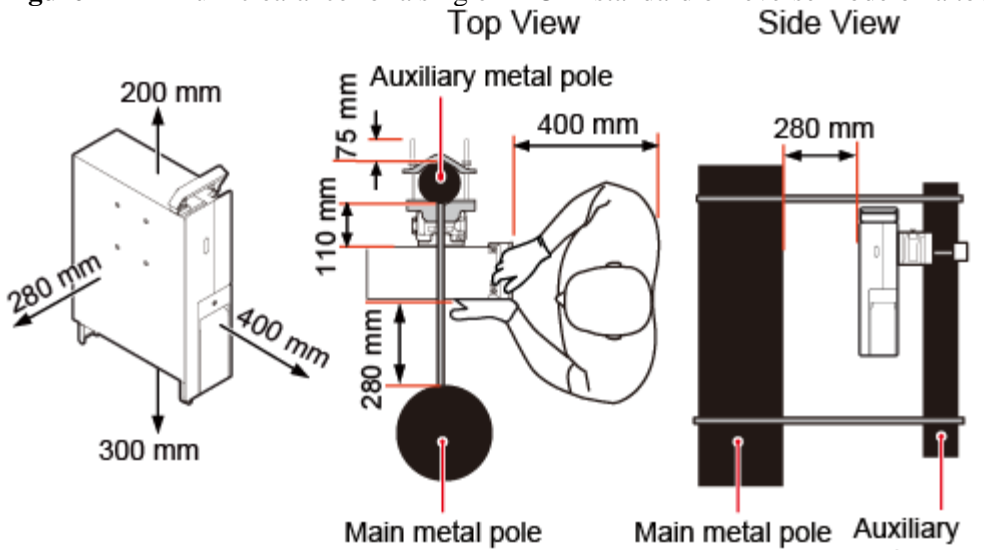

SRRA7C0053

Parent Topic: [Installation Clearance Requirements of an RRU](#)

Huawei Proprietary and Confidential Copyright © Huawei Technologies Co., Ltd.

Huawei Proprietary and Confidential

Copyright © Huawei Technologies Co., Ltd.

[Next topic >](#)

7.2.2.3.5.2 Clearance for Three or More RRUs

This section describes the recommended and minimum clearances for three or more RRUs.

⚠ NOTICE:

If an RRU is installed on the bitumen ground, the RRU must be at least 500 mm (700 mm or more is recommended) away from the bitumen ground. The following describes the space requirements for installing multiple RRUs on the non-bitumen ground.

📖 NOTE:

- The recommended clearances ensure normal running and provide appropriate space for operation and maintenance (O&M). If the installation space is sufficient, leave the recommended clearances after installing the equipment.
 - The minimum clearance ensures normal running and heat dissipation, but O&M activities such as checking indicator status and opening the cabling cavity cannot be properly conducted. If the installation space is restricted, leave the minimum clearance after installing the equipment.
-

- [Recommended Clearances for Multiple RRUs Installed in Stacked Mode](#)
- [Minimum Clearances for Multiple RRUs Installed in Stacked Mode](#)
- [Recommended Clearances for Multiple RRUs Installed in Standard or Reverse Mode on a Wall](#)
- [Minimum Clearances for Multiple RRUs Installed in Standard or Reverse Mode on a Wall](#)
- [Recommended Clearances for Multiple RRUs Installed in Side-Mounted Mode on a Wall](#)

Recommended Clearances for Multiple RRUs Installed in Stacked Mode

[Figure 1](#) shows the recommended clearances for multiple RRUs installed in stacked mode.

Figure 1 Recommended clearances for multiple RRUs installed in stacked mode

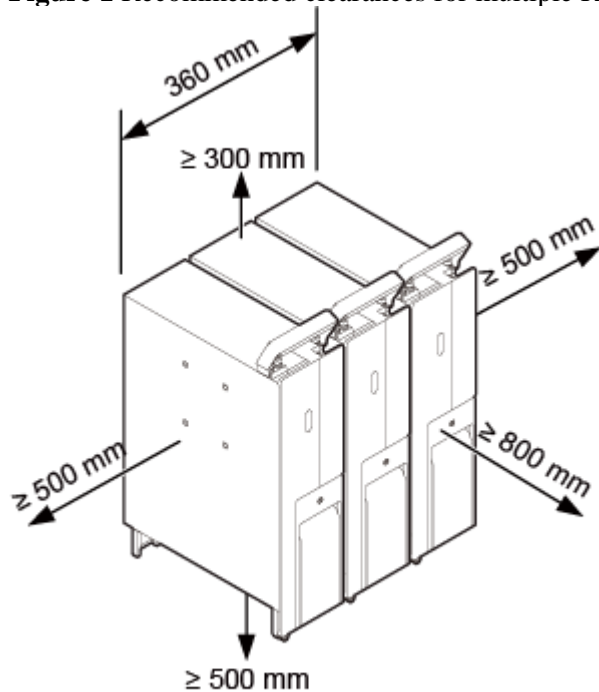

SRRA7C0054

Minimum Clearances for Multiple RRUs Installed in Stacked Mode

[Figure 2](#) shows the minimum clearances for multiple RRUs installed in stacked mode.

Figure 2 Minimum clearances for multiple RRUs installed in stacked mode

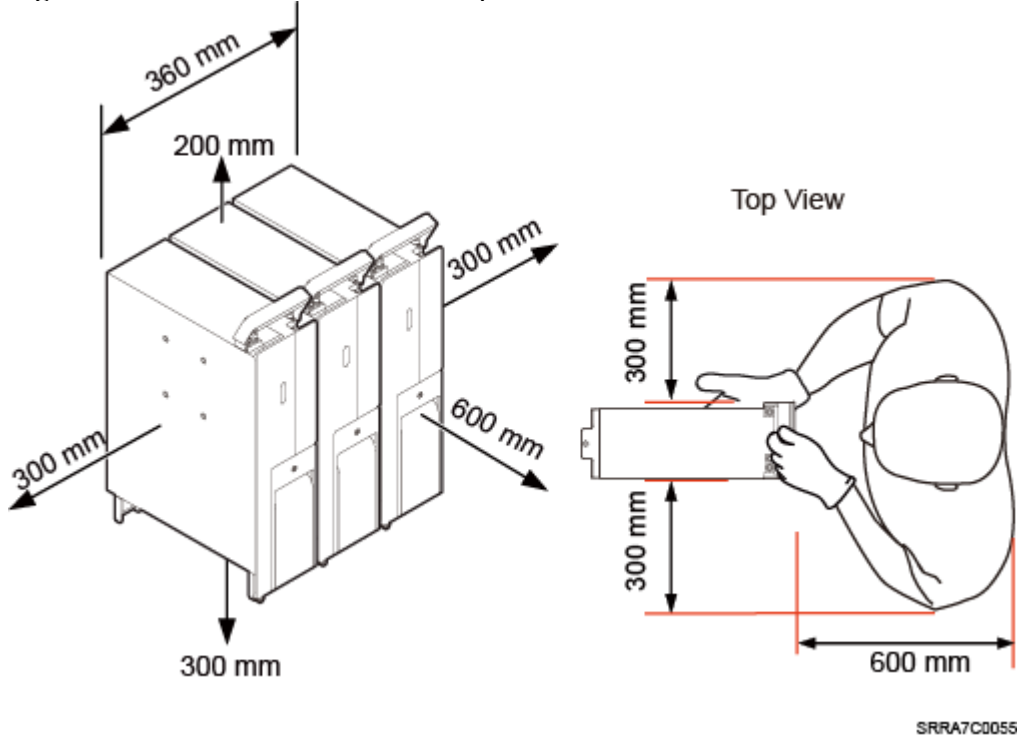

Recommended Clearances for Multiple RRUs Installed in Standard or Reverse Mode on a Wall

[Figure 3](#) shows the recommended clearances for multiple RRUs installed in standard or reverse mode on a wall.

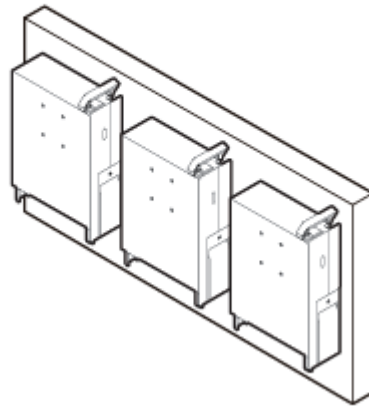
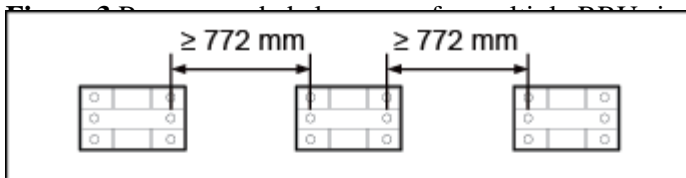

SRRA7C0015

talled in standard or reverse mode on a wall

Minimum Clearances for Multiple RRUs Installed in Standard or Reverse Mode on a Wall

[Figure 4](#) shows the minimum clearances for multiple RRUs installed in standard or reverse mode on a wall.

Figure 4 Minimum clearances for multiple RRUs installed in standard or reverse mode on a wall

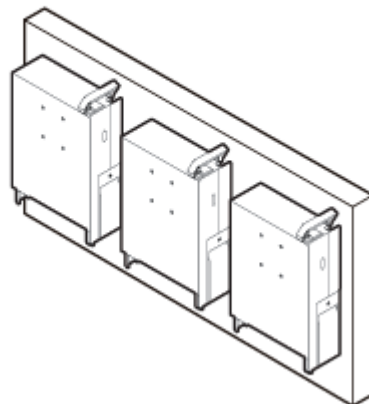
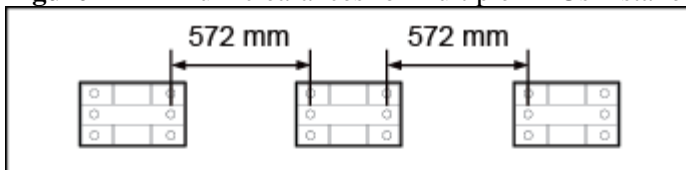

SRRA7C0016

Recommended Clearances for Multiple RRUs Installed in Side-Mounted Mode on a Wall

[Figure 5](#) shows the recommended clearances for multiple RRUs installed in side-mounted mode on a wall.

Figure 5 Recommended clearances for multiple RRUs installed in side-mounted mode on a wall

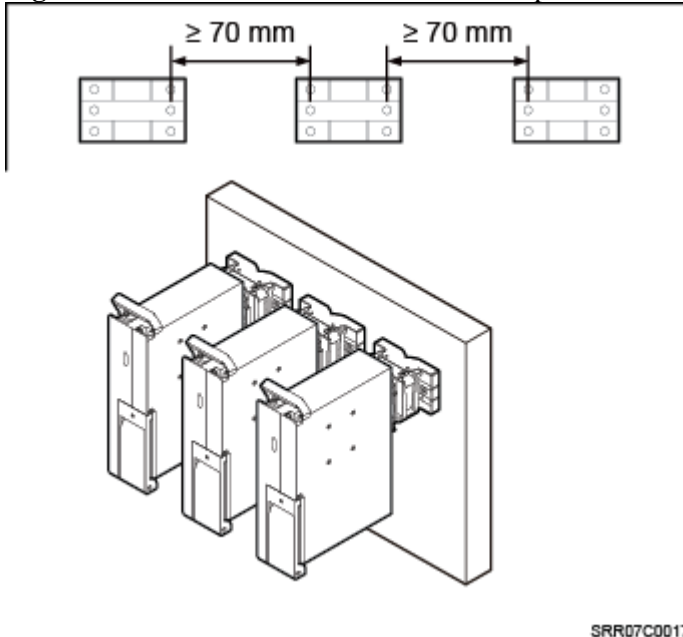

Parent Topic: [Installation Clearance Requirements of an RRU](#)

Huawei Proprietary and Confidential Copyright © Huawei Technologies Co., Ltd.

Huawei Proprietary and Confidential

Copyright © Huawei Technologies Co., Ltd.

[< Previous topic](#) [Next topic >](#)

7.2.2.3.5.3 Installation Spacing Between RRUs

This section describes the horizontal and vertical spacing between RRUs.

- [Recommended Horizontal Spacing Between RRUs](#)
- [Minimum Horizontal Spacing Between RRUs](#)
- [Recommended Vertical Spacing Between RRUs](#)
- [Minimum Vertical Spacing Between RRUs](#)

Recommended Horizontal Spacing Between RRUs

[Figure 1](#) shows the recommended horizontal spacing between RRUs.

Figure 1 Recommended horizontal spacing between RRUs

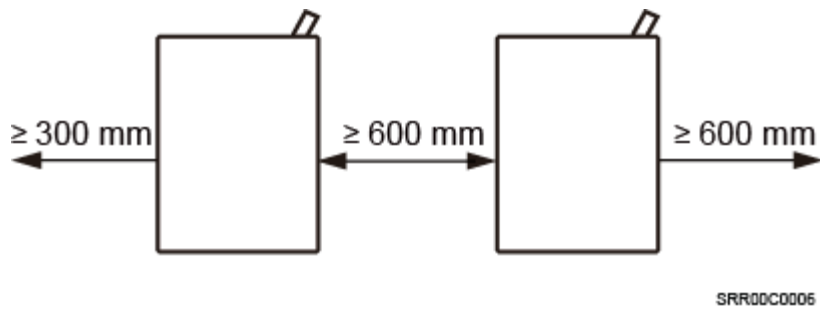

Minimum Horizontal Spacing Between RRUs

[Figure 2](#) shows the minimum horizontal spacing between RRUs.

Figure 2 Minimum horizontal spacing between RRUs

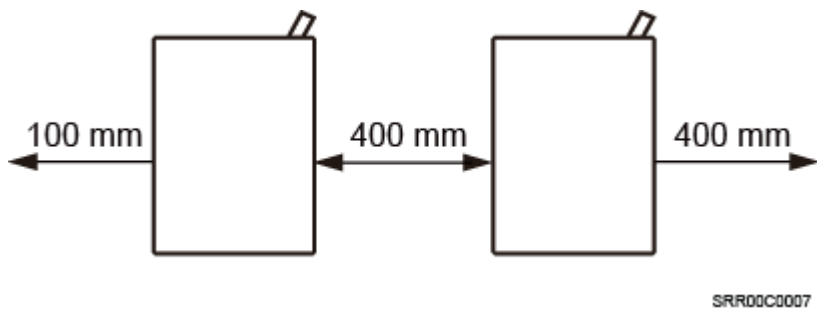

Recommended Vertical Spacing Between RRUs

[Figure 3](#) shows the recommended vertical spacing between RRUs.

Figure 3 Recommended vertical spacing between RRUs

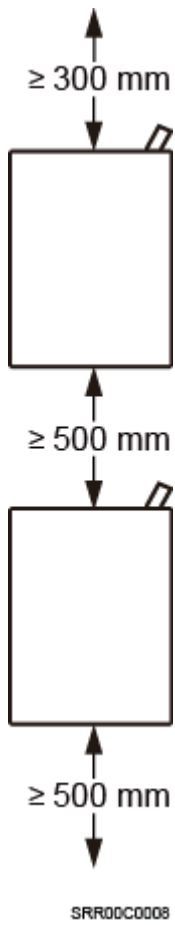

Minimum Vertical Spacing Between RRUs

[Figure 4](#) shows the minimum vertical spacing between RRUs.

Figure 4 Minimum vertical spacing between RRUs

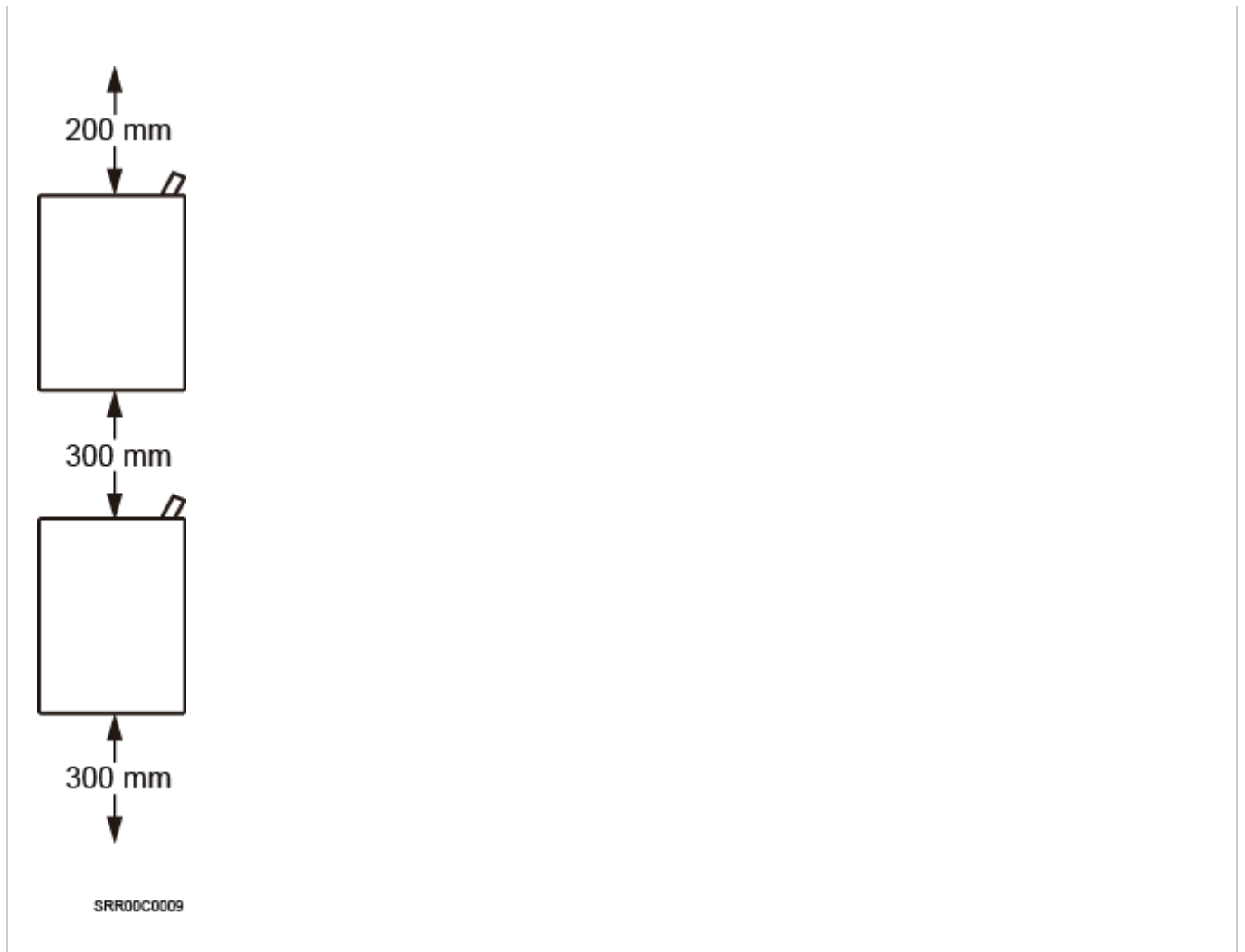

Parent Topic: [Installation Clearance Requirements of an RRU](#)

Huawei Proprietary and Confidential Copyright © Huawei Technologies Co., Ltd.

Huawei Proprietary and Confidential

Copyright © Huawei Technologies Co., Ltd.

[< Previous topic](#)

7.2.2.4 Unpacking the Equipment

This chapter describes how to unpack and check the delivered equipment to ensure that all the materials are included and intact.

Context

 **NOTE:**

When transporting, moving, or installing the equipment, components, or parts, you must:

- The base stations need to be transported to the site before they are installed. Do not unpack them or change the packages of them before transportation.
- Prevent them from colliding with doors, walls, shelves, or other objects.

- Wear clean gloves, and avoid touching the equipment, components, or parts with bare hands, sweat-soaked gloves, or dirty gloves.
 - Transportation of the base stations must comply with requirements of ETSI 300 019-1-2 class 2.3. For the goods damage caused by non-standard and violent transportation or non-human factors (such as natural disasters), the transportation entity should take the responsibility.
-

 **NOTICE:**

- After a cabinet or a BBU is unpacked, it must be powered on within 7 days.
 - After an RRU is unpacked, it must be powered on within 24 hours.
-

Procedure

1. Check the total number of articles in each case according to the packing list.

If ...	Then ...
The total number tallies with the packing list	Go to 2 .
The total number does not tally with the packing list	Find out the cause and report any missing articles to the local Huawei office.

2. Check the exterior of the packing case.

If ...	Then ...
The outer packing is intact	Go to 3 .
The outer packing is severely damaged or soaked	Find out the cause and report it to the local Huawei office.

3. Check the type and quantity of the equipment in the cases according to the packing list.

If ...	Then ...
Types and quantity of the article tally with those on the packing list	Sign the <i>Packing List</i> with the customer.
Either shipment shortage, wrong shipment or damaged articles.	Report to the local Huawei office.

4.  **CAUTION:**

- To protect the equipment and prevent damage to the equipment, you are advised to keep the unpacked equipment and packing materials indoors, take photos of the stocking environment, packing case or carton, packing materials, and any rusted or eroded equipment, and then file the photos.
 - Verify that the insulation layers of all RRU cables are intact. If the insulation layers are damaged or broken, water will penetrate into the cables, which may cause damages to RRUs or human injury.
-

7.2.2.5 Installation Process

The installation process involves installing an **RRU** and RRU cables, checking the RRU hardware installation, and powering on an RRU.

[Figure 1](#) shows the installation process.

Figure 1 Process of installing an RRU

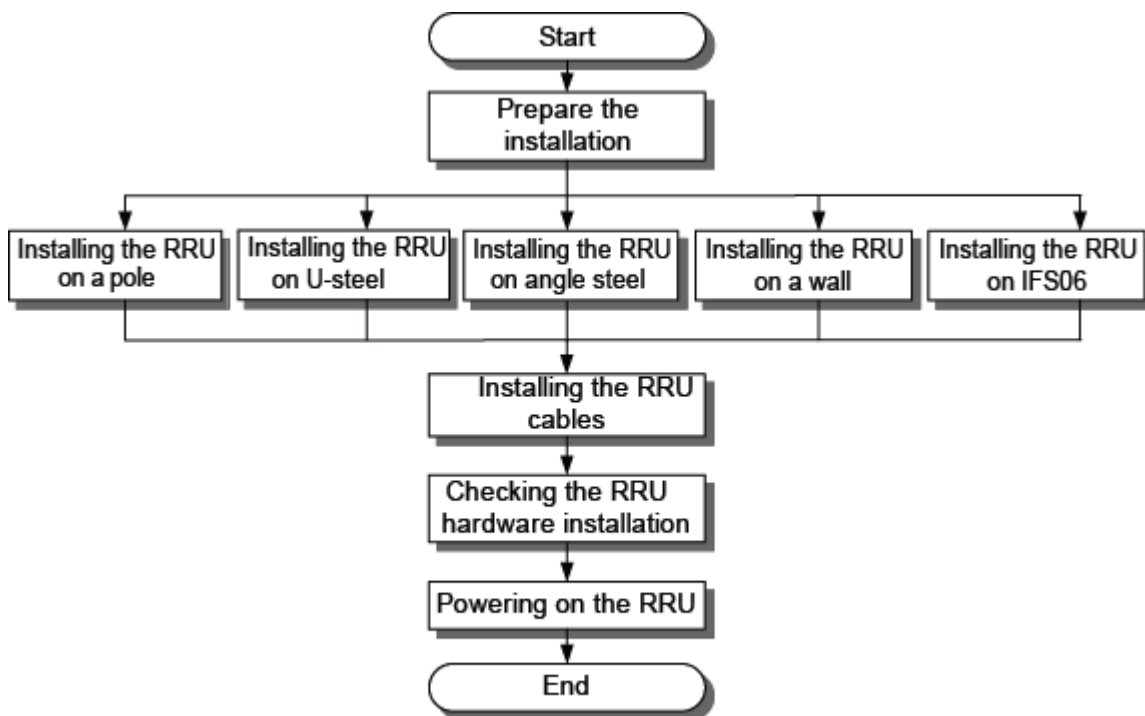

IPR42C0001

7.2.2.6 Hoisting an RRU and Related Cables onto a Tower

This section describes the procedure for hoisting an **RRU** and related cables onto a tower and the precautions that must be taken.

[Hoisting an RRU onto a Tower](#)

This section describes the procedures and precautions for hoisting an RRU and its mounting kits onto a tower. In tower-mounted scenarios, the RRU can be installed on a pole, U-steel, or angle steel.

[Hoisting Optical Fibers onto a Tower](#)

This section describes the procedure for hoisting optical fibers onto a tower and the precautions that must be taken.

[Hoisting Power Cables onto a Tower](#)

This section describes the procedure for hoisting power cables onto a tower and the precautions that must be taken.

Huawei Proprietary and Confidential Copyright © Huawei Technologies Co., Ltd.

Huawei Proprietary and Confidential

Copyright © Huawei Technologies Co., Ltd.

[< Previous topic](#) [Next topic >](#)

7.2.2.6.1 Hoisting an RRU onto a Tower

This section describes the procedures and precautions for hoisting an **RRU** and its mounting kits onto a tower. In tower-mounted scenarios, the RRU can be installed on a pole, U-steel, or angle steel.

Prerequisites

When the RRU is powered by an AC/DC power module, you need to install the AC/DC power module onto the RRU before hoisting them onto a tower. For detailed operations, see *OPM15M(Ver.B) User Guide* or *OPM50M(Ver.B) User Guide*.

NOTICE:

- Do not stand the RRU upright because the **RF** ports cannot support the weight of the RRU.
 - Place a foam pad or cardboard under the RRU to protect the RRU housing from damage during the installation.
-

Procedure

1. After climbing up to the tower, installation engineer A secures the fixed pulley to the tower platform support and leads the lifting sling through the fixed pulley.
2. Installation engineer C binds the mounting kits using the lifting sling and traction sling on the ground, as shown in [Figure 1](#). Then installation engineer B pulls the lifting sling downwards, and installation engineer C pulls the traction sling outwards to protect the mounting kits from colliding with the tower.

Figure 1 Binding mounting kits for the RRU

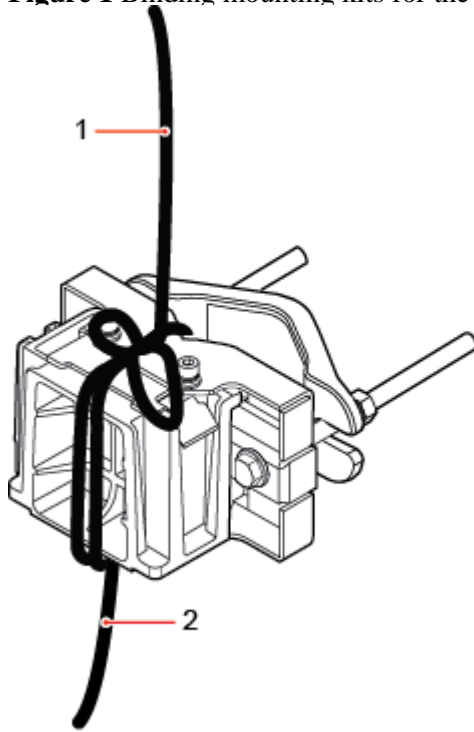

HIR47C0139

(1) Lifting sling

(2) Traction sling

3. Installation engineer A catches the mounting kits and then unties the slings.
4. Install the mounting kits. For detailed operations, see steps 1 to 3 in [Installing a Single RRU](#).
5. Installation engineer C binds the RRU using the lifting sling and traction sling, as shown in [Figure 2](#). The binding methods in [Figure 3](#) and [Figure 4](#) are incorrect.

Figure 2 Binding the RRU

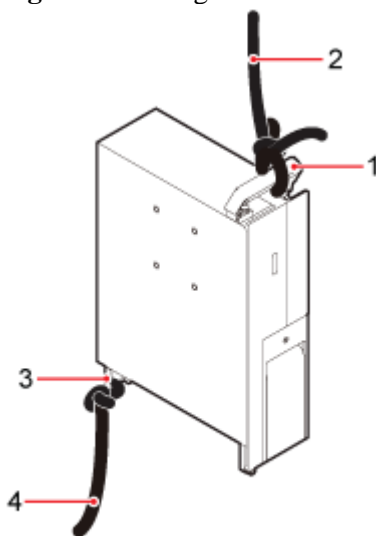

HIRA7C0033

(1) Handle

(2) Lifting sling

(3) Traction eye

(4) Traction sling

Figure 3 Incorrect binding method (1)



HIRA7C0034

Figure 4 Incorrect binding method (2)



HIRA7C0035

6. Hoist the RRU onto the tower, as shown in [Figure 5](#). Installation engineer B pulls the lifting sling downwards, and installation engineer C pulls the traction sling outwards to protect the RRU from colliding with the tower.

Figure 5 Hoisting the RRU onto the tower

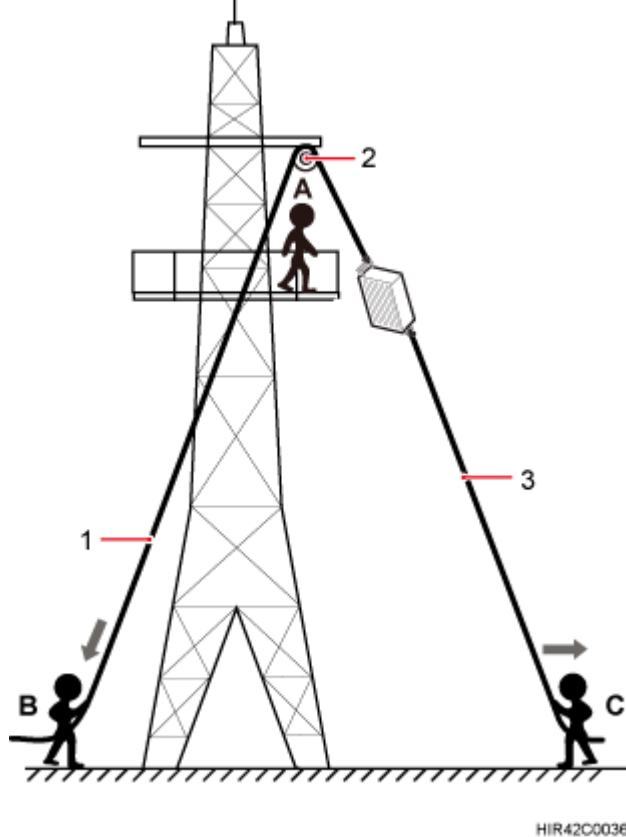

(1) Lifting sling

(2) Fixed pulley

(3) Traction sling

⚠ NOTICE:

- The load-bearing capacity of each sling must be greater than 200 kg (441 lb) and the diameter of each sling must be less than 25 mm (0.98 in.).
- When hoisting each device onto a tower, protect them from colliding with the tower.
- Hoist the RRU onto the tower before it is installed on a pole, angle steel, or U-steel.
- Do not hoist anything using the traction eye.

-
7. Installation engineer A catches the RRU hoisted onto the tower.
 8. Installation engineer A installs the RRU onto the main bracket and uses an inner hexagon torque screwdriver to tighten the captive screw into the hole of the attachment plate and main bracket to 5 N·m (44.25 lbf·in.). For detailed operations, see steps 4 and 5 in [Installing a Single RRU](#).
 9. Untie the lifting sling and traction sling.

📖 NOTE:

The procedure for hoisting the RRU and its mounting kits onto the tower is for your reference only.

Parent Topic: [Hoisting an RRU and Related Cables onto a Tower](#)

Huawei Proprietary and Confidential Copyright © Huawei Technologies Co., Ltd.

7.2.2.6.2 Hoisting Optical Fibers onto a Tower

This section describes the procedure for hoisting optical fibers onto a tower and the precautions that must be taken.

Context

Cabling requirements for power cables are met. For details, see [Cabling Requirements](#).

Procedure

1. Hoist the optical fibers onto the tower, as shown in [Figure 1](#).

Figure 1 Hoisting optical fibers onto the tower

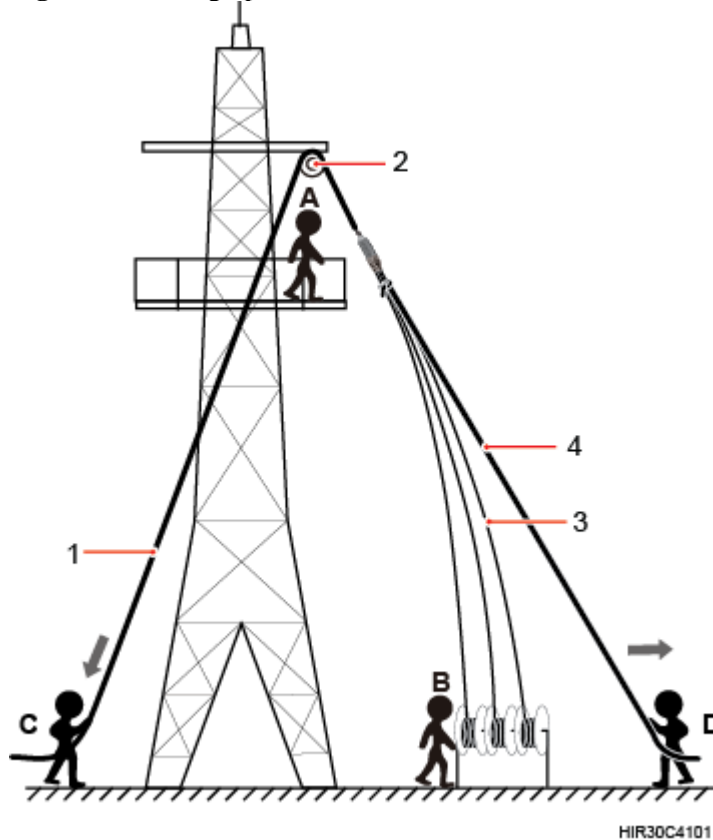

(1) Lifting sling

(2) Fixed pulley

(3) optical fibers

(4) Traction sling

NOTICE:

Before hoisting optical fibers onto the tower, connect the optical fibers to the [RRU](#) or [BBU](#) based on the labels on both ends of the cables and determine the hoisting direction.

- a. After climbing up to the tower, installation engineer A secures the fixed pulley to the tower platform support and leads the lifting sling through the fixed pulley.
- b. Installation engineer B places the fiber coiler for coiling optical fibers on the fiber spools, and installation engineer D lead the lifting sling through the stretch sling of the optical fibers and use the other sling as a traction sling to secure the cables 4 m (13.12 ft) away from the lifting sling, as shown in [Figure 2](#).

Figure 2 Binding optical fibers

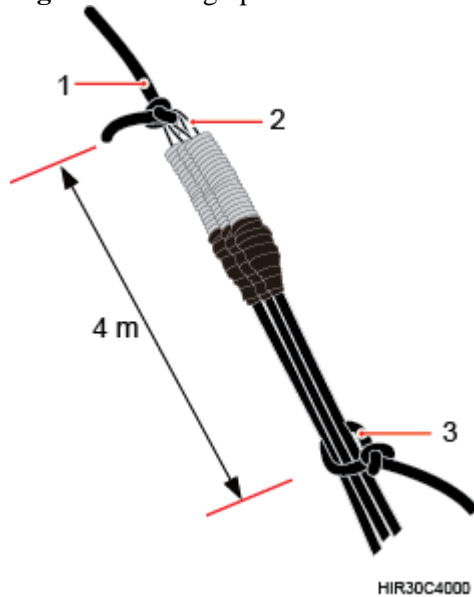

(1) Lifting sling

(2) Stretch sling

(3) Traction sling

⚠ NOTICE:

Do not remove the stretch sling and protection pipe or bind optical fibers using one sling, as shown in [Figure 3](#).

Figure 3 Incorrect binding method



- c. Installation engineer B rotates the fiber spools at the speed of 5 m (16.4 ft) to 15 m (49.21 ft) per minute to coil the optical fibers.
 - d. Installation engineer C pulls the lifting sling downwards, and installation engineer D pulls the traction sling outwards to protect the optical fibers from colliding with the tower.
2. Secure the optical fibers to the tower vertically using cable clips.
 3. Remove the lifting sling, traction sling, and protection pipe.

 **NOTE:**

The procedure for hoisting the optical fibers onto the tower is for your reference only.

Parent Topic: [Hoisting an RRU and Related Cables onto a Tower](#)

Huawei Proprietary and Confidential Copyright © Huawei Technologies Co., Ltd.

Huawei Proprietary and Confidential

Copyright © Huawei Technologies Co., Ltd.

[< Previous topic](#) [Next topic >](#)

7.2.2.6.3 Hoisting Power Cables onto a Tower

This section describes the procedure for hoisting power cables onto a tower and the precautions that must be taken.

Context

Cabling requirements for power cables are met. For details, see [Cabling Requirements](#).

The procedure for adding a connector to the [RRU](#) power cable on the RRU side is done under the tower.

Procedure

1. Hoist the power cables onto the tower, as shown in [Figure 1](#).

Figure 1 Hoisting power cables onto the tower

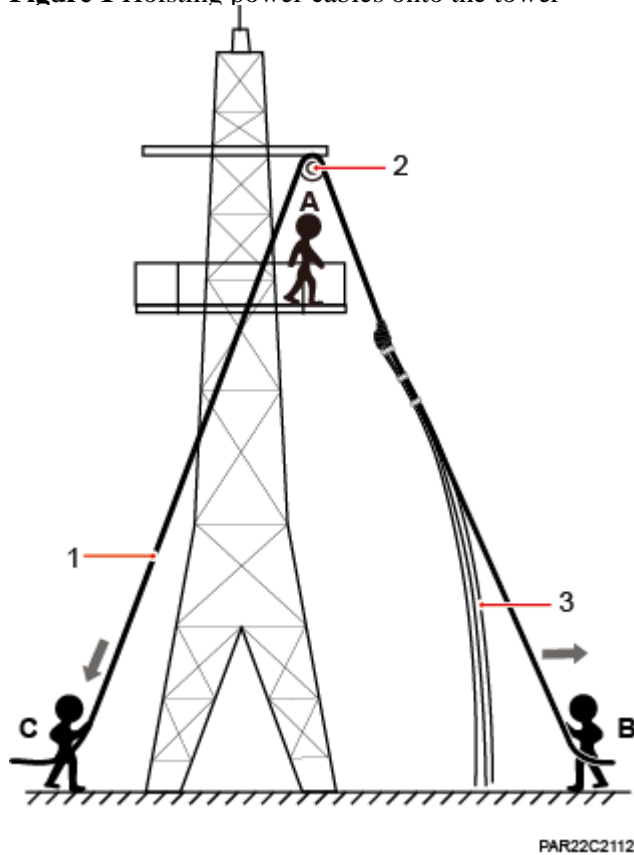

(1) Lifting sling

(2) Fixed pulley

(2) power cables

- a. After climbing up to the tower, installation engineer A secures the fixed pulley to the tower platform support and leads the lifting sling through the fixed pulley.
- b. Installation engineer B secures three cable ties to the power cable connector, and then secures the power cable to the lifting sling, as shown in [Figure 2](#).

 **NOTE:**

The connector on the power cable in the figure is only an example. The actual connector may vary according to the situation.

Figure 2 Binding cable ties

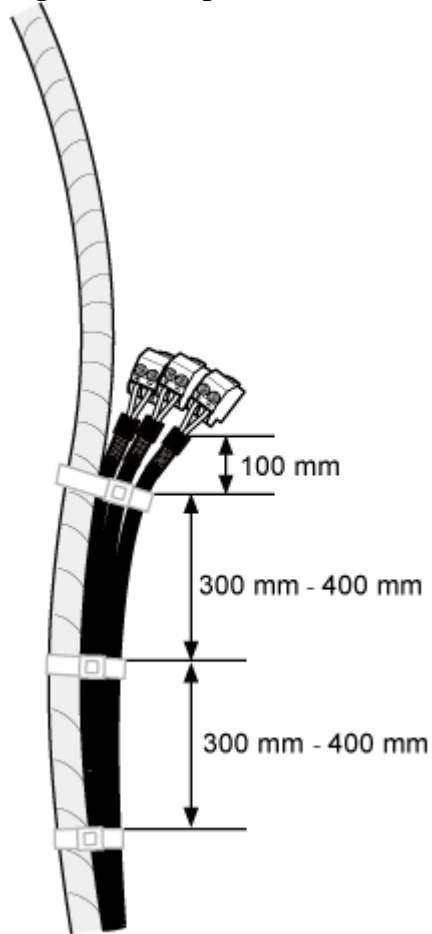

PAR22C2010

- c. Installation engineer B wraps the power cable connector with a layer of PVC insulation tape, as shown in [Figure 3](#).

 **NOTE:**

Wrap the PVC insulation tape from 30 mm (1.18 in.) away from one end of the connector until it reaches the other end of the connector. The total length of the wrapped connector is 100 mm (3.94 in.).

Figure 3 Wrapping the PVC insulation tape

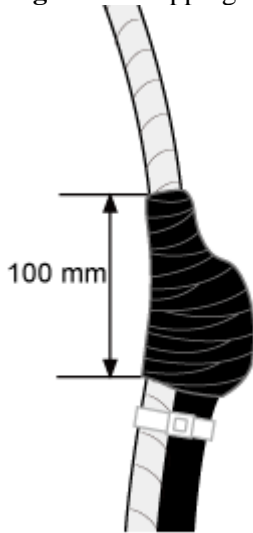

PAR22C2011

- d. Installation engineer C pulls the lifting sling downwards, and installation engineer B pulls the other end of the lifting sling outwards to protect the power cables from colliding with the tower.
2. Secure the power cables to the tower vertically using cable clips.
3. Remove the cable ties, PVC insulation tape, and lifting sling.

 **NOTE:**

The procedure for hoisting the power cables onto the tower is for your reference only.

Parent Topic: [Hoisting an RRU and Related Cables onto a Tower](#)

Huawei Proprietary and Confidential Copyright © Huawei Technologies Co., Ltd.

Huawei Proprietary and Confidential

Copyright © Huawei Technologies Co., Ltd.

[< Previous topic](#)

7.2.2.7 Installing the RRU

This chapter describes the procedure for installing the [RRU](#). The procedure for installing the RRU varies depending on installation options.

[Mounting Kits for an RRU](#)

This section describes the bracket assembly and the attachment plate for an RRU.

[Installing the RRU on a Pole](#)

One or more RRUs can be installed on a pole.

[Installing an RRU on U-steel](#)

This section describes the procedure and precautions for installing an RRU on U-steel. An RRU can be installed on U-steel secured on the ground or a tower. Each piece of U-steel allows only one RRU to be installed in standard or reverse mode.

[Installing an RRU on Angle Steel](#)

This section describes the process and precautions for installing an RRU on angle steel. An RRU can be installed on angle steel secured on the ground or a tower. Each piece of angle steel allows only one RRU to be installed in standard or reverse mode.

[Installing an RRU on a Wall](#)

This section describes the procedure and precautions for installing an RRU on a wall.

[Installing an RRU on an IFS06](#)

This section describes the process and precautions for installing an RRU on an IFS06.

Huawei Proprietary and Confidential Copyright © Huawei Technologies Co., Ltd.

Huawei Proprietary and Confidential

Copyright © Huawei Technologies Co., Ltd.

[< Previous topic](#) [Next topic >](#)

7.2.2.7.1 Mounting Kits for an RRU

This section describes the bracket assembly and the attachment plate for an RRU.

[Figure 1](#) shows the front and side of an RRU.

Figure 1 Front and side view of an RRU

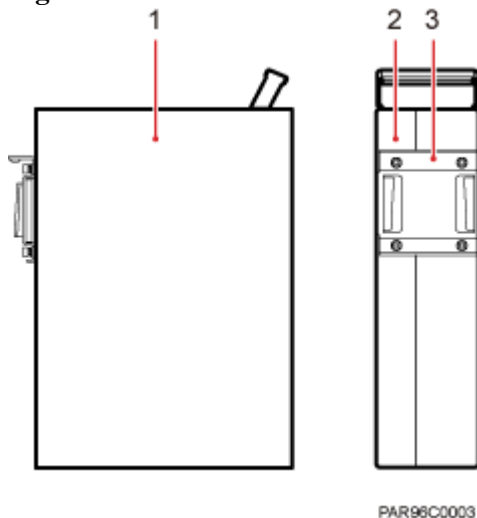

(1) Front view

(2) Side view

(3) Attachment plate

[Figure 2](#) shows the bracket assembly for an RRU.



NOTE:

The RRU described in this document must use the required RRU mounting kits in new deployment scenarios.

Figure 2 12 L blade RRU mounting kit

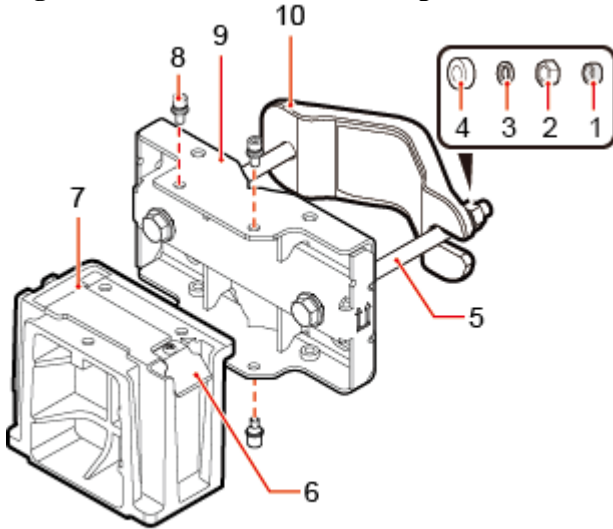

PIR42C0004

- | | | | | |
|-------------------------------------|----------------------|-------------------------|-------------------------------|------------------------|
| (1) Plastic cap | (2) Standard M10 nut | (3) Spring washer | (4) Thick flat washer | (5) Square-neck bolt |
| (6) Hoist clamp on the main bracket | (7) Main bracket | (8) Inner hexagon screw | (9) Pole installation bracket | (10) Auxiliary bracket |

Parent Topic: [Installing the RRU](#)

Huawei Proprietary and Confidential Copyright © Huawei Technologies Co., Ltd.

Huawei Proprietary and Confidential

Copyright © Huawei Technologies Co., Ltd.

[Next topic >](#)

7.2.2.7.2 Installing the RRU on a Pole

One or more RRUs can be installed on a pole.

[Installing a Single RRU](#)

This section describes the procedure and precautions for installing a single [RRU](#) on a pole.

[Installing Two RRUs](#)

This section describes the procedure and precautions for installing two RRUs on a pole.

[Installing Three or More RRUs](#)

This section describes the procedure and precautions for installing three or more RRUs on a pole.

Parent Topic: [Installing the RRU](#)

Huawei Proprietary and Confidential Copyright © Huawei Technologies Co., Ltd.

Huawei Proprietary and Confidential

Copyright © Huawei Technologies Co., Ltd.

[< Previous topic](#) [Next topic >](#)

7.2.2.7.2.1 Installing a Single RRU

This section describes the procedure and precautions for installing a single RRU on a pole.

Prerequisites

- Before you install an RRU on a pole secured on a tower, the RRU and its mounting kits are hoisted onto the tower. For details, see [Hoisting an RRU onto a Tower](#).
- The hoist clamp on the main bracket is secured properly.

NOTICE:

- Do not stand an RRU upright because the RF ports cannot support the weight of the RRU.
 - Place a foam pad or cardboard under an RRU to protect the RRU housing from damage during the installation.
-

Procedure

1. Determine a position for installing the mounting kits.
 - If the RRU is installed on a tower, determine a position for installing the mounting kits according to the instructions in [Clearance for a Single RRU](#).
 - If the RRU is installed on the ground, determine a position for installing the mounting kits according to [Figure 1](#).

Figure 1 Distance between the mounting kits and the ground

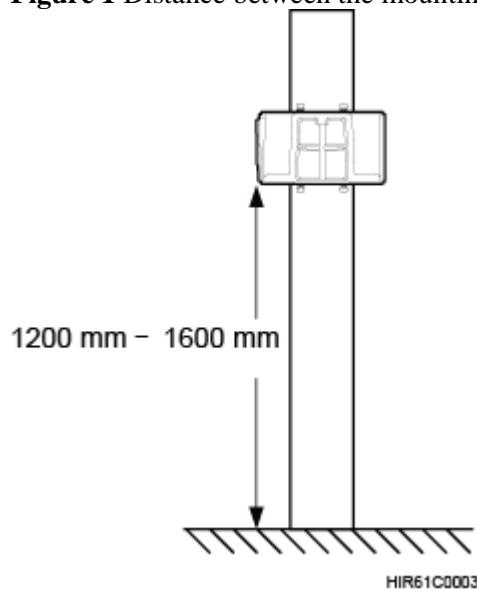

NOTE:

As shown in the figure above, it is recommended that the mounting kits be installed at a position 1200 mm (47.24 in.) to 1600 mm (59.06 in.) high above the ground. If the space is insufficient, only the [Installation Clearance Requirements of an RRU](#) needs to be provided.

2. Install the RRU mounting kits, as shown in [Figure 2](#).

Figure 2 Installing the RRU mounting kits

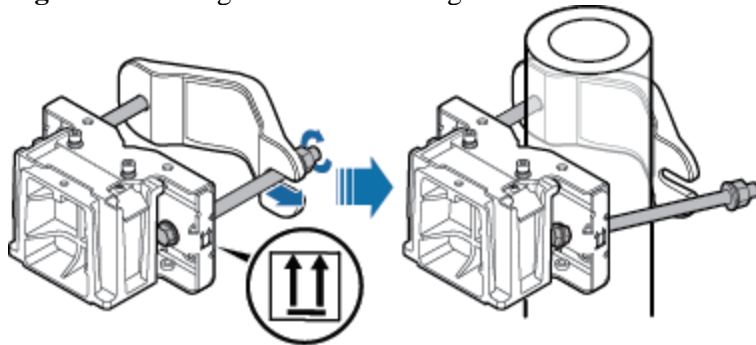

HIR42C0004

 **NOTE:**

Ensure that the arrows on the mounting kits are pointing up.

- a. Adjust the position of the nut and remove the square-neck bolt at the open end from the slot on the auxiliary bracket.
 - b. Slide the mounting kits onto the pole horizontally and insert the square-neck bolt into the slot.
3. Use a 16 mm (0.63 in.) M10 torque wrench to tighten the nuts to 40 N·m (354.03 lbf·in.) so that the mounting kits are secured onto the pole, as shown in [Figure 3](#).

 **NOTICE:**

Tighten the nuts on the two square-neck bolts simultaneously. After the main and auxiliary brackets are secured properly, measure the spacing between the brackets on both sides and ensure that the spacing is the same on the two sides.

Figure 3 Securing the RRU mounting kits

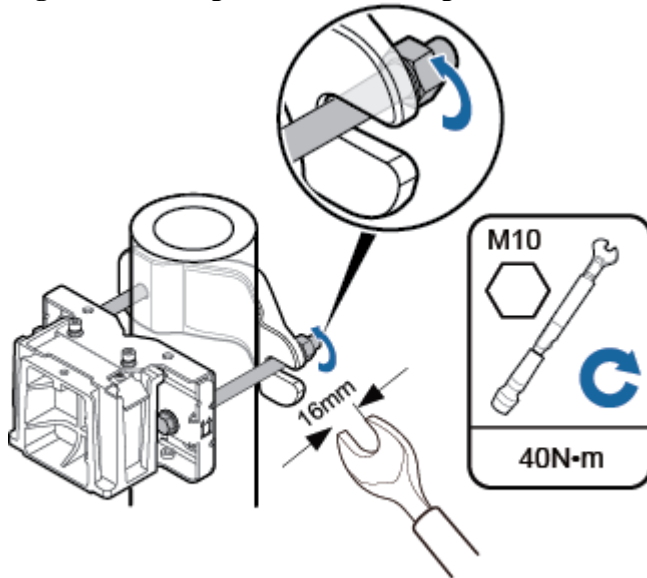

HIR42C0005

4. Install the RRU onto the main bracket, as shown in [Figure 4](#).

Figure 4 Installing the RRU onto the main bracket

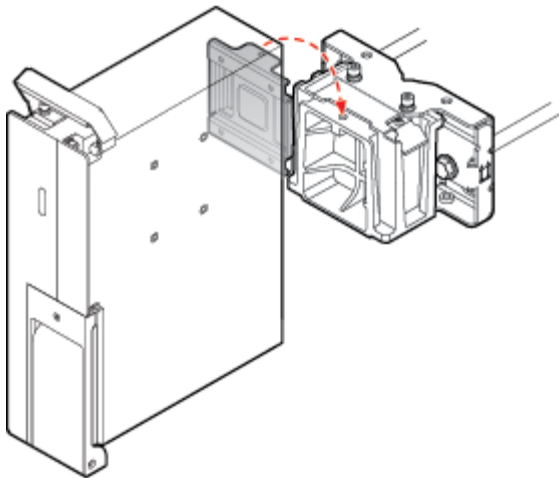

HIRA7C0056

5. Use an inner hexagon torque screwdriver to tighten the captive screw into the holes on the top of the attachment plate and main bracket to 5 N·m (44.25 lbf·in.) so that the attachment plate and main bracket are firmly secured, as shown in [Figure 5](#).

Figure 5 Securing the captive screw into the connection hole

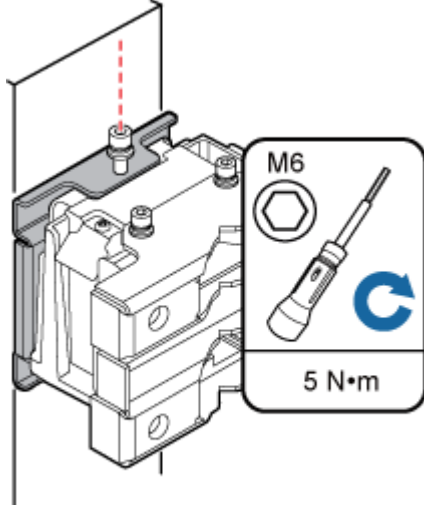

HIR42C0011

Parent Topic: [Installing the RRU on a Pole](#)

Huawei Proprietary and Confidential Copyright © Huawei Technologies Co., Ltd.

Huawei Proprietary and Confidential

Copyright © Huawei Technologies Co., Ltd.

[Next topic >](#)

7.2.2.7.2.2 Installing Two RRUs

This section describes the procedure and precautions for installing two RRUs on a pole.

Prerequisites

The hoist clamp on the main bracket is secured properly.

NOTICE:

- Do not stand an **RRU** upright because the **RF** ports cannot support the weight of the RRU.
 - Place a foam pad or cardboard under an RRU to protect the RRU housing from damage during the installation.
-

Procedure

1. Install the first RRU onto the main bracket, as shown in [Figure 1](#). For details, see [Installing a Single RRU](#).

Figure 1 Installing the first RRU onto the main bracket

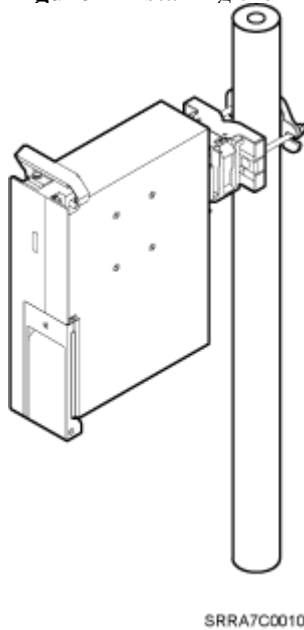

2. Use an M6 inner hexagon screwdriver to loosen the four hex socket screws from the main bracket and pole mounting kit on the second set of mounting kits, and remove the main bracket, as shown in [Figure 2](#).

Figure 2 Removing the RRU main bracket

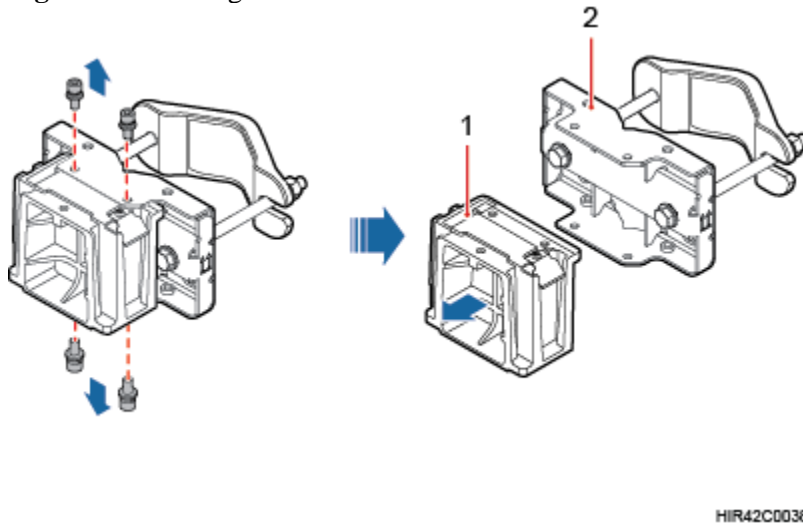

(1) Main bracket

(2) Pole mounting kit

3. Install the removed main bracket on one side of the first main bracket, as shown in [Figure 3](#).

⚠ NOTICE:

The second main bracket must be installed, with the open ends of U-shaped slots on both sides facing downwards.

Figure 3 Installing the second main bracket

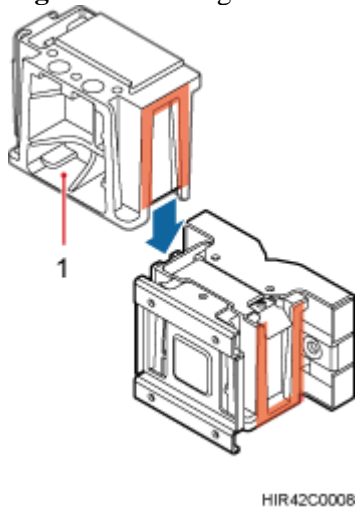

(1) Removed main bracket

 **NOTE:**

The main mounting bracket for installing a blade RRU can connect to the main mounting bracket for installing a common RRU in the scenarios of adding RRUs, as shown in [Figure 4](#).

Figure 4 Connecting to the main mounting bracket for installing a common RRU

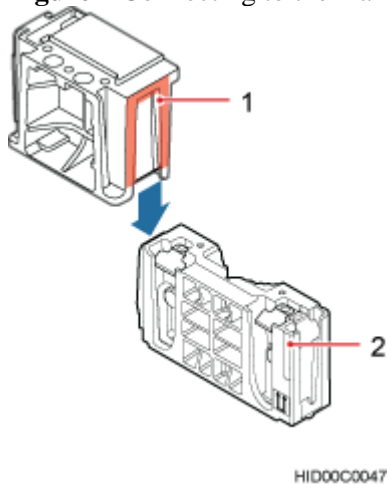

(1) Main mounting bracket for a blade RRU

(2) Main mounting bracket for a common RRU

4. Install the second RRU onto the main bracket, as shown in [Figure 5](#).

Figure 5 Installing the second RRU onto the main bracket

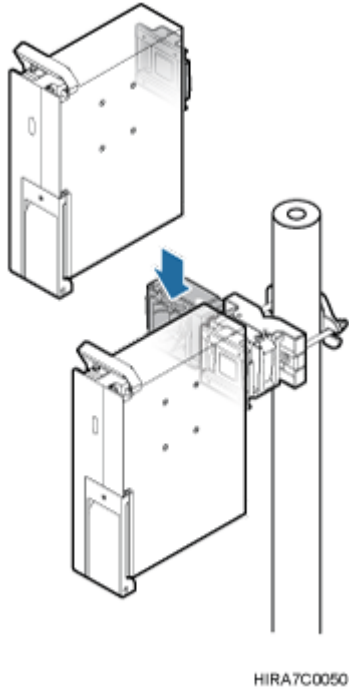

⚠ NOTICE:

After installing each RRU on its main bracket, use an inner hexagon torque screwdriver to tighten the captive screw into the holes on the top of the attachment plate and main bracket to 5 N·m (44.25 lbf·in.) so that the attachment plate and main bracket are firmly secured, as shown in [Figure 6](#).

Figure 6 Securing the captive screw into the connection hole

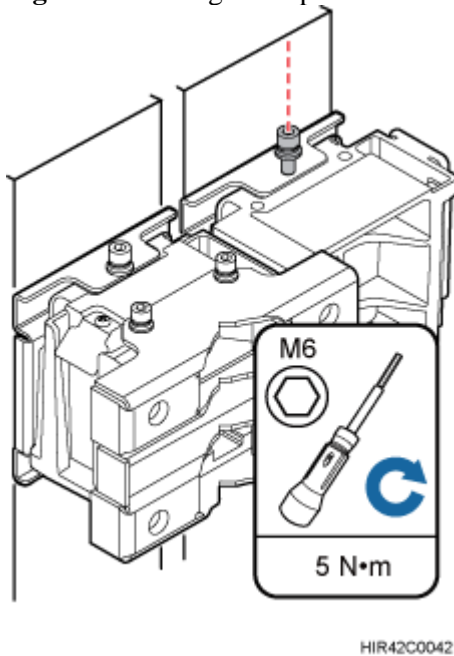

5. Install the sheet metal tab for fixing the neighboring RRUs, as shown in [Figure 7](#).

Figure 7 Installing the sheet metal tab

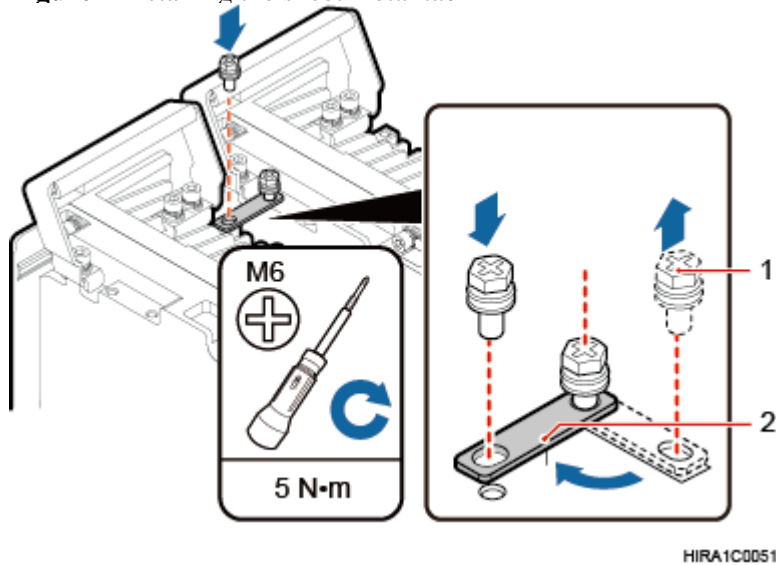

(1) Screw

(2) Sheet metal tab

- a. Use an M6 Phillips screwdriver to loosen the screw on the sheet metal tab farther from the handle of the second RRU and remove the screw.
- b. Use an M6 Phillips screwdriver to loosen the screw on the sheet metal tab closer to the handle of the second RRU. Then, rotate the sheet metal tab to align the vacant hole in the sheet metal tab with a hole on the top of the first RRU.
- c. Insert the removed screw into the hole on the top of the first RRU and use an M6 torque screwdriver to tighten the screw to 5 N·m (44.25 lbf·in.).

Parent Topic: [Installing the RRU on a Pole](#)

Huawei Proprietary and Confidential Copyright © Huawei Technologies Co., Ltd.

Huawei Proprietary and Confidential

Copyright © Huawei Technologies Co., Ltd.

[< Previous topic](#) [Next topic >](#)

7.2.2.7.2.3 Installing Three or More RRUs

This section describes the procedure and precautions for installing three or more RRUs on a pole.

Prerequisites

The hoist clamp on the main bracket is secured properly.

NOTICE:

- Do not stand an RRU upright because the RF ports cannot support the weight of the RRU.
 - Place a foam pad or cardboard under an RRU to protect the RRU housing from damage during the installation.
-

Context

A pole supports three, four, or six RRUs. The procedures for installing them are the same. The following provides an example for the procedure of installing four RRUs on a pole.

NOTICE:

RRUs can be stacked only when installed on one or more poles, and a maximum of three RRUs can be stacked.

Procedure

1. Install two RRUs, as shown in [Figure 1](#). For details, see [Installing Two RRUs](#).

Figure 1 Two RRUs installed on a pole

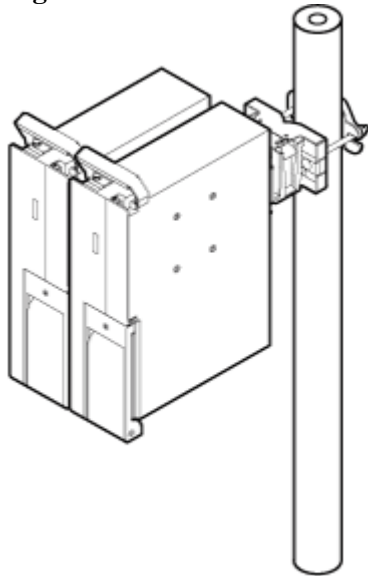

SRR47C0011

2. Use an M6 inner hexagon screwdriver to loosen the four hex socket screws from the main bracket and pole mounting kit on the second set of mounting kits, and remove the main bracket, as shown in [Figure 2](#).

Figure 2 Removing the RRU main bracket

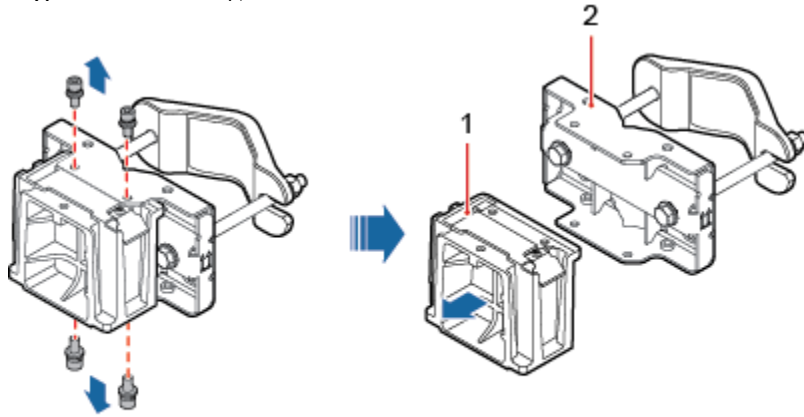

HIR42C0038

(1) Main bracket

(2) Pole mounting kit

3. Install the third main bracket and install the third RRU onto the third main bracket. Then, use an inner hexagon torque screwdriver to tighten the captive screw into the holes on the top of the attachment plate and main bracket for the RRU to 5 N·m (44.25 lbf·in.), as shown in [Figure 3](#).

⚠ NOTICE:

The third main bracket must be installed, with the open ends of U-shaped slots on both sides facing downwards.

Figure 3 Installing the third RRU onto the third main bracket

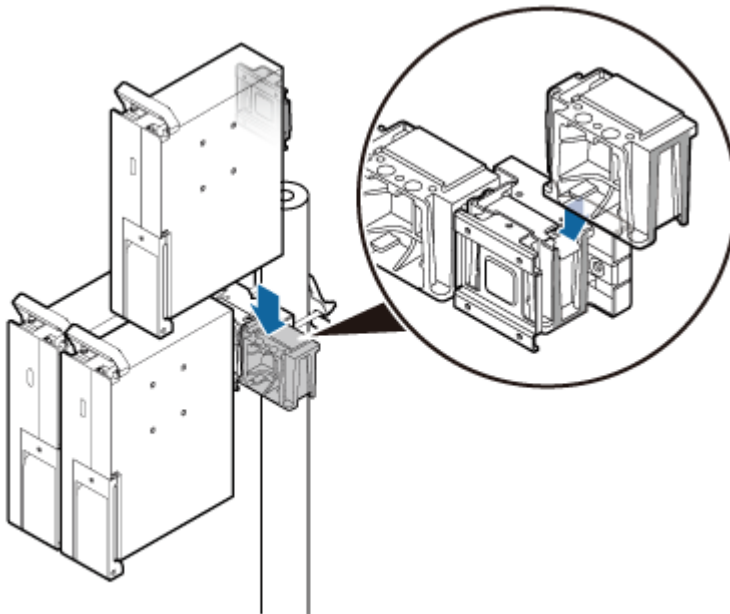

HIRA7C0055

📖 NOTE:

The main mounting bracket for installing a blade RRU can connect to the main mounting bracket for installing a common RRU in the scenarios of adding RRUs, as shown in [Figure 4](#).

Figure 4 Connecting to the main mounting bracket for installing a common RRU

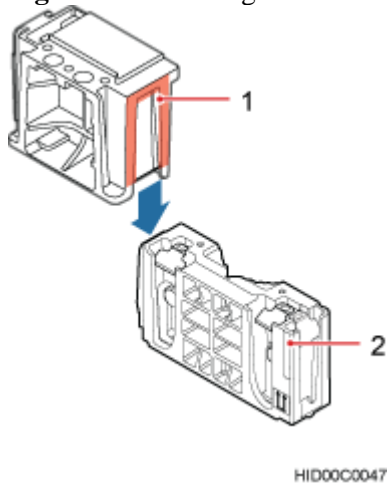

(1) Main mounting bracket for a blade RRU

(2) Main mounting bracket for a common RRU

4. Install the sheet metal tab for fixing the neighboring RRUs, as shown in [Figure 5](#).

Figure 5 Installing the sheet metal tab

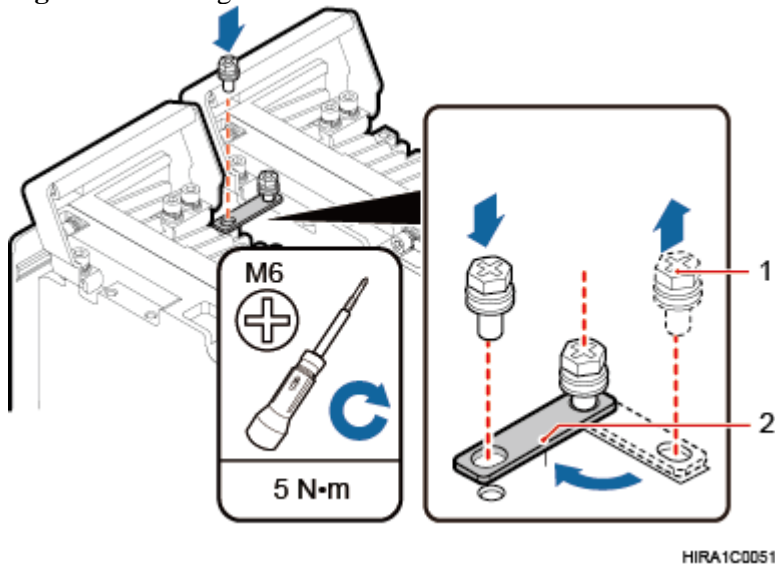

(1) Screw

(2) Sheet metal tab

- a. Use an M6 Phillips screwdriver to loosen the screw on the sheet metal tab farther from the handle of the first RRU and remove the screw.
- b. Use an M6 Phillips screwdriver to loosen the screw on the sheet metal tab closer to the handle of the first RRU. Then, rotate the sheet metal tab to align the vacant hole in the sheet metal tab with a hole on the top of the third RRU.
- c. Insert the removed screw into the hole on the top of the third RRU and use an M6 torque screwdriver to tighten the screw to 5 N·m (44.25 lbf·in.).

5. Install the second set of RRU mounting kits at least 80 mm (3.15 in.) above or below the first set of RRU mounting kits, as shown in [Figure 6](#).

Figure 6 Installing the second set of RRU mounting kits

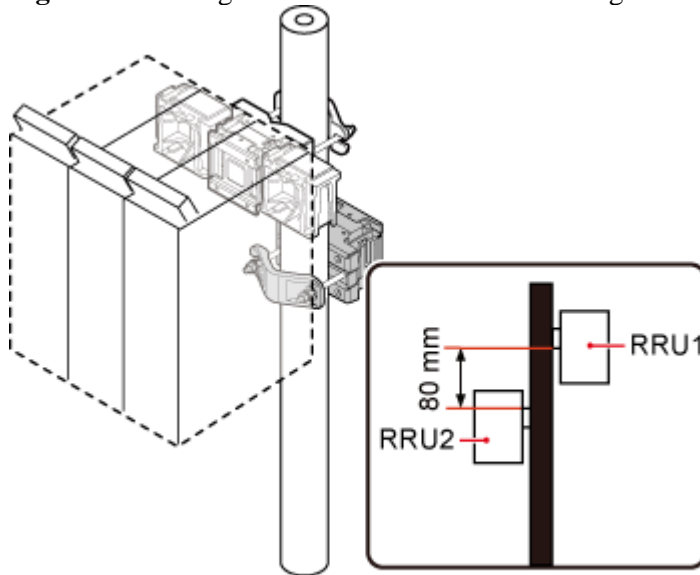

HIR42C0016

6. Install the fourth RRU onto the fourth main bracket, and use an inner hexagon torque screwdriver to tighten the captive screw into the holes on the top of the attachment plate and main bracket to 5 N·m (44.25 lbf·in.) so that the attachment plate and main bracket are firmly secured, as shown in [Figure 7](#).

Figure 7 Installing the fourth RRU onto the fourth main bracket

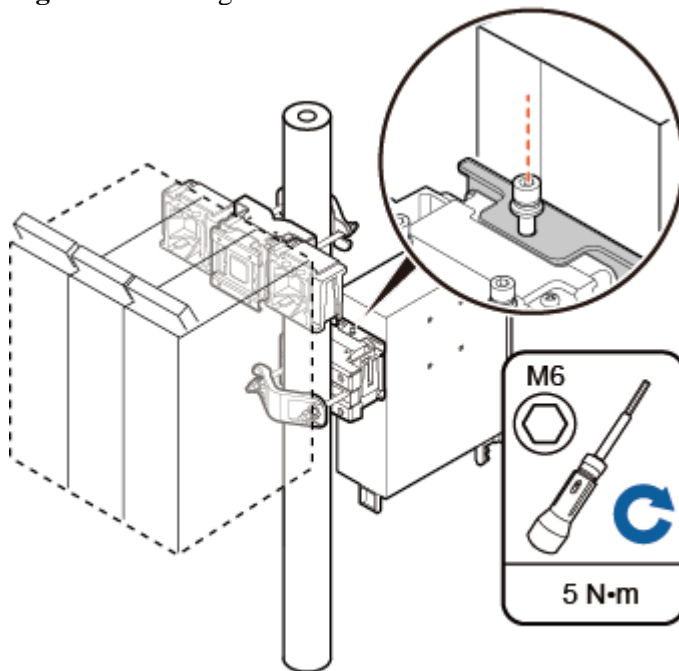

HIRA7C0017

Parent Topic: [Installing the RRU on a Pole](#)

Huawei Proprietary and Confidential Copyright © Huawei Technologies Co., Ltd.

7.2.2.7.3 Installing an RRU on U-steel

This section describes the procedure and precautions for installing an [RRU](#) on U-steel. An RRU can be installed on U-steel secured on the ground or a tower. Each piece of U-steel allows only one RRU to be installed in standard or reverse mode.

Prerequisites

- Before you install an RRU on U-steel secured on a tower, the RRU and its mounting brackets are hoisted onto the tower. For details, see [Hoisting an RRU onto a Tower](#).
- The hoist clamp on the main bracket is secured properly.

NOTICE:

- Do not stand an RRU upright because the [RF](#) ports cannot support the weight of the RRU.
 - Place a foam pad or cardboard under an RRU to protect the RRU housing from damage during the installation.
-

Context

[Figure 1](#) shows the top view of an RRU installed on U-steel.

NOTICE:

When the width of the narrower edges of the U-steel is less than 40 mm (1.57 in.), only the a and b modes are supported.

Figure 1 Top view of an RRU

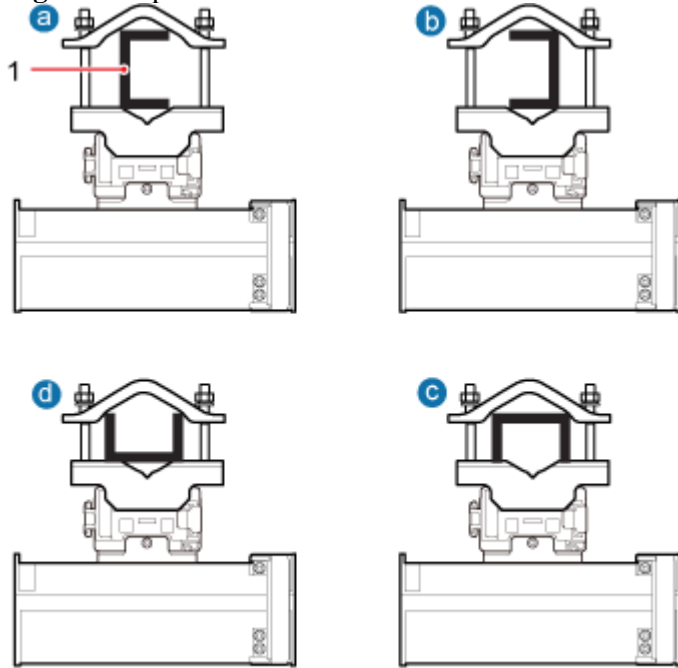

HIR96C0052

(1) U-steel

Procedure

1. Determine a position for installing the mounting kits.
 - If the RRU is installed on a tower, determine a position for installing the mounting kits according to the instructions in [Clearance for a Single RRU](#).
 - If the RRU is installed on the ground, determine a position for installing the mounting kits according to the instructions in [Figure 2](#).

Figure 2 Distance between the mounting kits and the ground

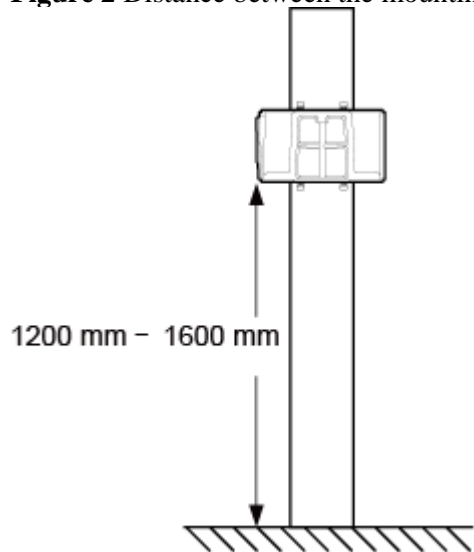

HIR61C0003

 **NOTE:**

As shown in the figure above, it is recommended that the mounting kits be installed at a position 1200 mm (47.24 in.) to 1600 mm (59.06 in.) high above the ground. If the space is insufficient, only the [Installation Clearance Requirements of an RRU](#) needs to be provided.

2. Install the RRU mounting kits, as shown in [Figure 3](#).

Figure 3 Installing the RRU mounting kits

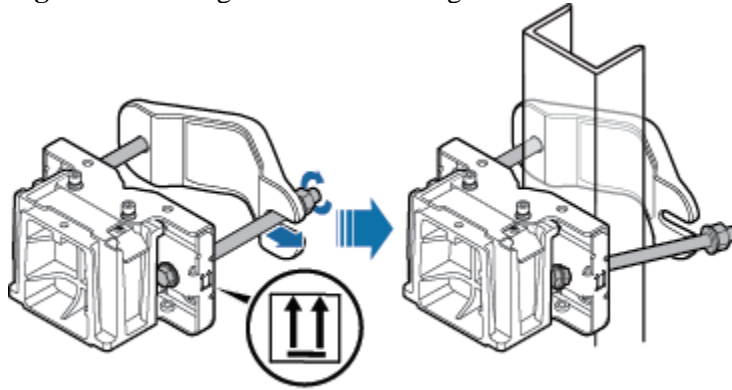

HIR42C0020

 **NOTE:**

Ensure that the arrows on the pole mounting kits are pointing up.

- a. Adjust the position of the nut and remove the square-neck bolt at the open end from the slot on the auxiliary bracket.
 - b. Slide the mounting kits onto the U-steel horizontally and insert the square-neck bolt into the slot.
3. Use a 16 mm (0.63 in.) M10 torque wrench to tighten the nuts to 40 N·m (354.03 lbf·in.) so that the mounting kits are secured onto the U-steel, as shown in [Figure 4](#).

 **NOTICE:**

Tighten the nuts on the two square-neck bolts simultaneously. After the main and auxiliary brackets are secured properly, measure the spacing between the mounting kits on both sides and ensure that the spacing is the same on the two sides.

Figure 4 Securing the RRU mounting kits

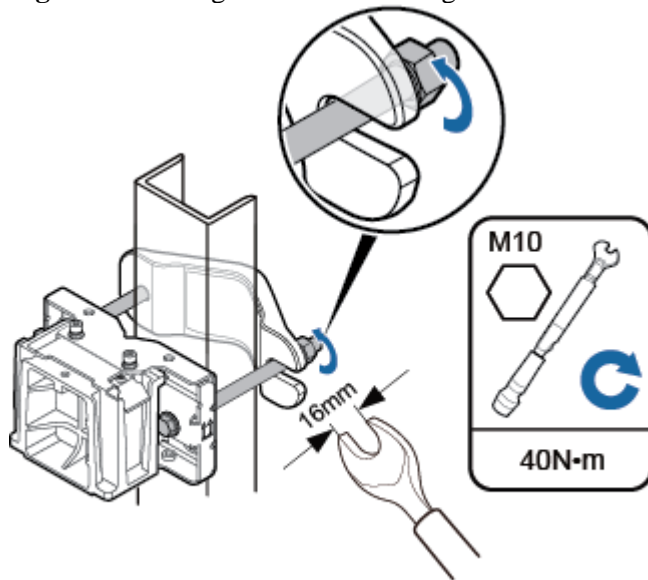

HIR42C0021

4. Use an inner hexagon torque screwdriver to remove the attachment plate from one side of the RRU, reinstall the attachment plate onto the rear of the RRU, and tighten the four stainless screws to 5 N·m (44.25 lbf·in.), as shown in [Figure 5](#).

Figure 5 Installing the attachment plate onto the rear of the RRU

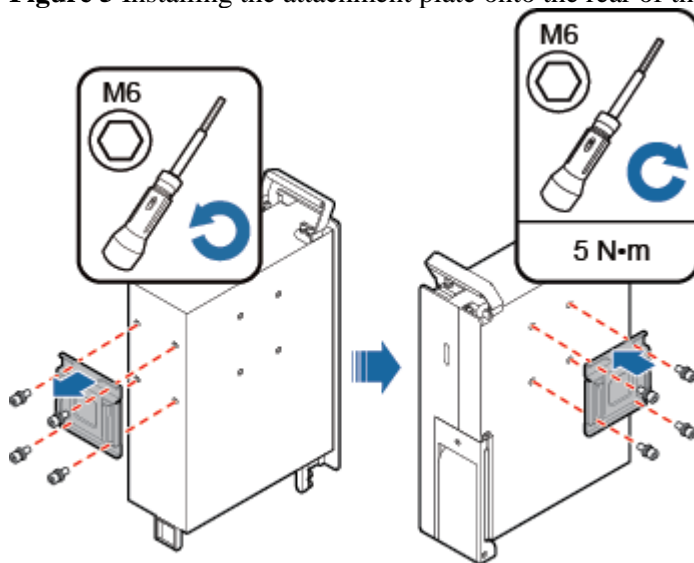

HIA07C0059

5. Install the RRU onto the main bracket, as shown in [Figure 6](#).

Figure 6 Installing the RRU onto the main brackets

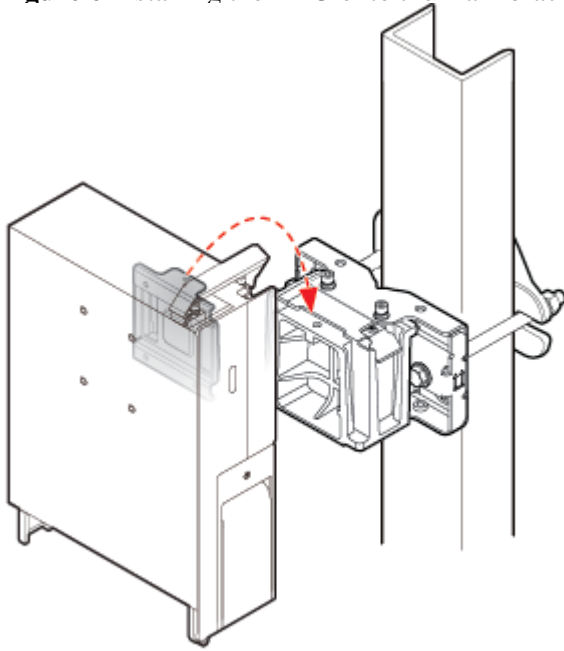

HIRA7C0013

6. Use an inner hexagon torque screwdriver to tighten the captive screw into the holes on the top of the attachment plate and main bracket to 5 N·m (44.25 lbf·in.) so that the attachment plate and main bracket are firmly secured, as shown in [Figure 7](#).

Figure 7 Securing the captive screw into the connection hole

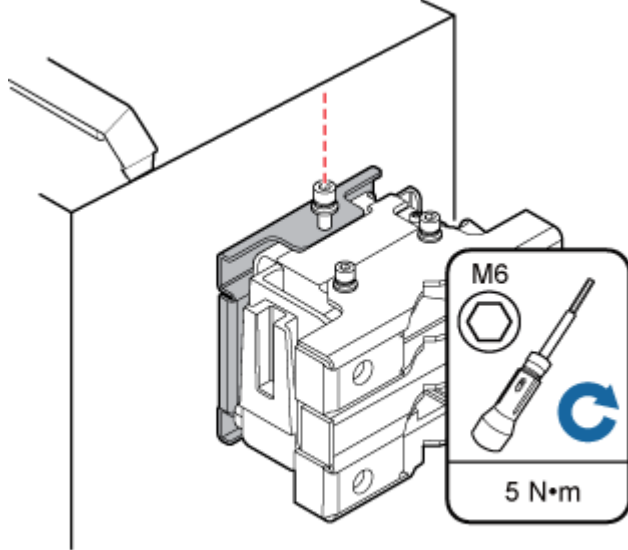

HIR42C0041

Parent Topic: [Installing the RRU](#)

Huawei Proprietary and Confidential Copyright © Huawei Technologies Co., Ltd.

Huawei Proprietary and Confidential

Copyright © Huawei Technologies Co., Ltd.

[< Previous topic](#) [Next topic >](#)

7.2.2.7.4 Installing an RRU on Angle Steel

This section describes the process and precautions for installing an [RRU](#) on angle steel. An RRU can be installed on angle steel secured on the ground or a tower. Each piece of angle steel allows only one RRU to be installed in standard or reverse mode.

Prerequisites

- Before you install an RRU on U-steel secured on a tower, the RRU and its mounting brackets are hoisted onto the tower. For details, see [Hoisting an RRU onto a Tower](#).
- The hoist clamp on the main bracket is secured properly.

NOTICE:

- Do not stand an RRU upright because the [RF](#) ports cannot support the weight of the RRU.
 - Place a foam pad or cardboard under an RRU to protect the RRU housing from damage during the installation.
-

Context

[Figure 1](#) shows the top view of an RRU installed on angle steel.

Figure 1 Top view of an RRU

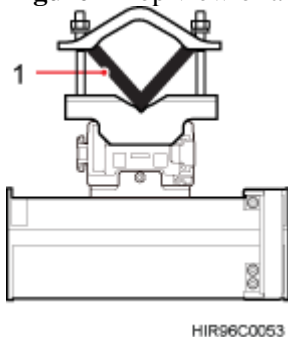

(1) Angle steel

Procedure

1. Determine a position for installing the mounting kits.
 - If the RRU is installed on angle steel secured on a tower, determine a position for installing the mounting brackets according to the instructions in [Clearance for a Single RRU](#).
 - If the RRU is installed on angle steel secured on the ground, determine a position for installing the mounting brackets according to [Figure 2](#).

Figure 2 Distance between the mounting kits and the ground

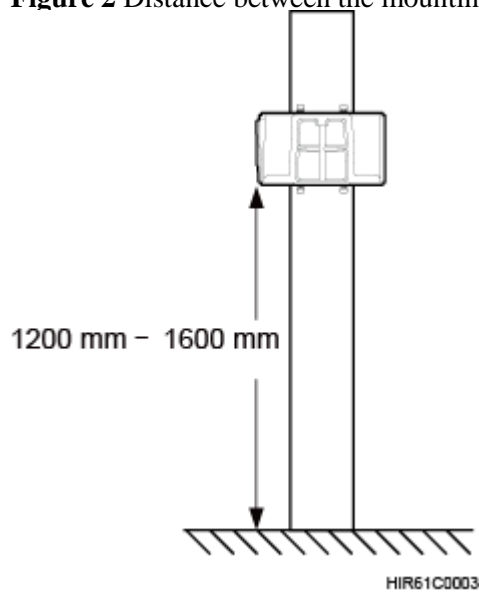

 **NOTE:**

As shown in the figure above, it is recommended that the mounting kits be installed at a position 1200 mm (47.24 in.) to 1600 mm (59.06 in.) high above the ground. If the space is insufficient, only the [Installation Clearance Requirements of an RRU](#) needs to be provided.

2. Install the RRU mounting kits, as shown in [Figure 3](#).

Figure 3 Installing the RRU mounting kits

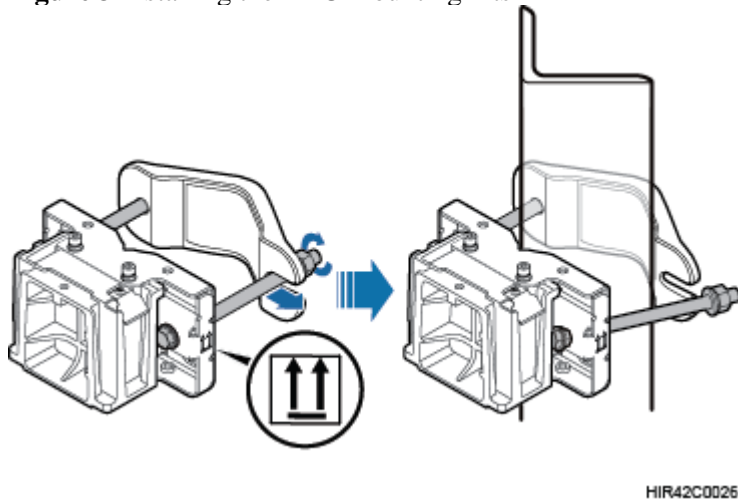

 **NOTE:**

Ensure that the arrows on the pole mounting kits are pointing up.

- a. Adjust the position of the nut and remove the square-neck bolt at the open end from the slot on the auxiliary bracket.
- b. Slide the mounting brackets onto the angle steel horizontally and insert the square-neck bolt into the slot.

3. Use a 16 mm (0.63 in.) M10 torque wrench to tighten the nuts to 40 N·m so that the mounting kits are secured onto the angle steel, as shown in [Figure 4](#).

⚠NOTICE:

Tighten the nuts on the two square-neck bolts simultaneously. After the main and auxiliary brackets are secured properly, measure the spacing between the mounting kits on both sides and ensure that the spacing is the same on the two sides.

Figure 4 Securing the RRU mounting kits

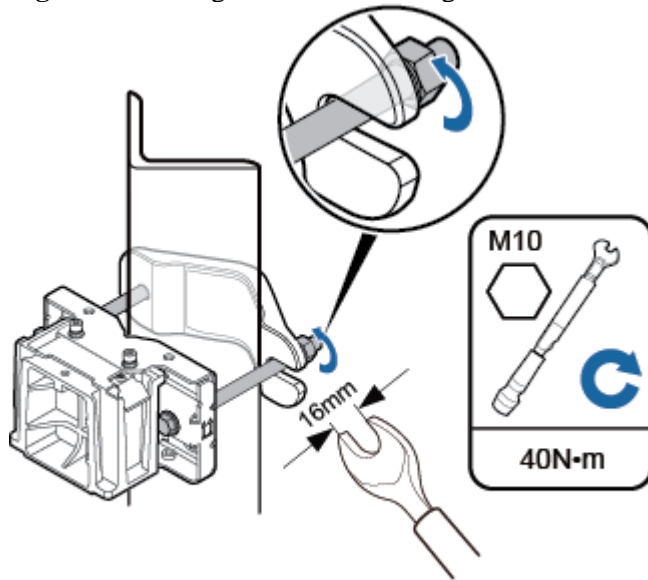

HIR42C0027

4. Use an inner hexagon torque screwdriver to remove the attachment plate from one side of the RRU, reinstall the attachment plate onto the rear of the RRU, and tighten the four stainless screws to 5 N·m (44.25 lbf·in.), as shown in [Figure 5](#).

Figure 5 Installing the attachment plate onto the rear of the RRU

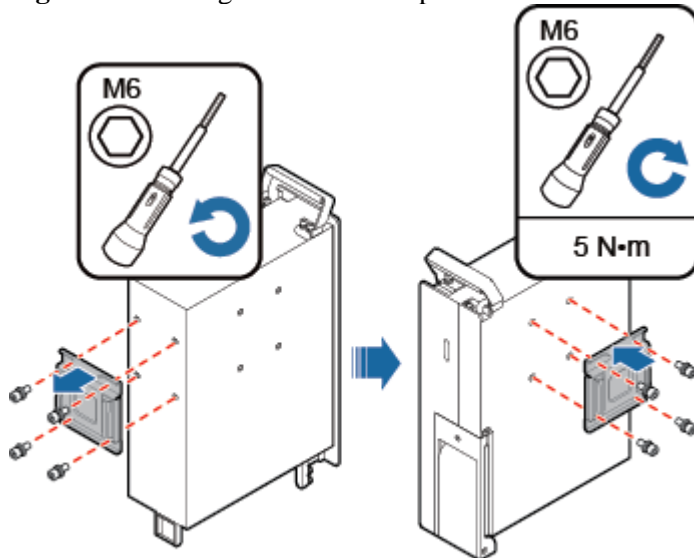

HIA07C0059

5. Install the RRU onto the main bracket, as shown in [Figure 6](#).

Figure 6 Installing the RRU onto the main brackets

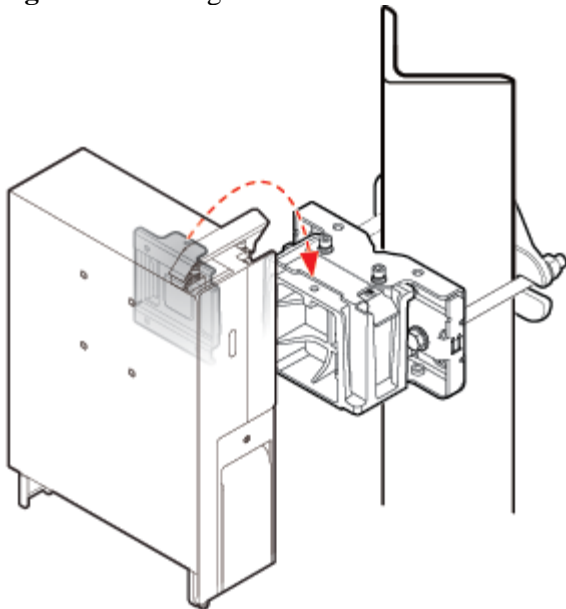

HIRA7C0054

6. Use an inner hexagon torque screwdriver to tighten the captive screw into the holes on the top of the attachment plate and main bracket to 5 N·m (44.25 lbf·in.) so that the attachment plate and main bracket are firmly secured, as shown in [Figure 7](#).

Figure 7 Securing the captive screw into the connection hole

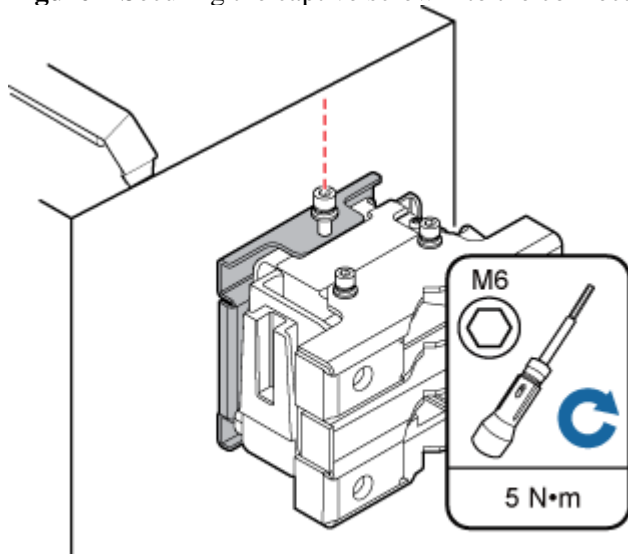

HIR42C0041

Parent Topic: [Installing the RRU](#)

Huawei Proprietary and Confidential Copyright © Huawei Technologies Co., Ltd.

Huawei Proprietary and Confidential

Copyright © Huawei Technologies Co., Ltd.

[< Previous topic](#) [Next topic >](#)

7.2.2.7.5 Installing an RRU on a Wall

This section describes the procedure and precautions for installing an [RRU](#) on a wall.

Prerequisites

The hoist clamp on the main bracket is secured properly.

NOTICE:

- Do not stand an RRU upright because the [RF](#) ports cannot support the weight of the RRU.
 - Place a foam pad or cardboard under an RRU to protect the RRU housing from damage during the installation.
-

Context

The wall on which RRUs are installed must meet the following requirements:

- For each RRU, the wall must be able to bear a weight four times heavier than the RRU's weight and the bolts' pulling force of 1.25 kN (281.25 lbf) vertical to the wall.
- Expansion bolts must be tightened to 30 N·m (265.52 lbf·in.) to ensure that the bolts work properly and the wall remains intact.

Procedure

1. Disassemble the RRU mounting kits, as shown in [Figure 1](#).

Figure 1 Disassembling the RRU mounting kits

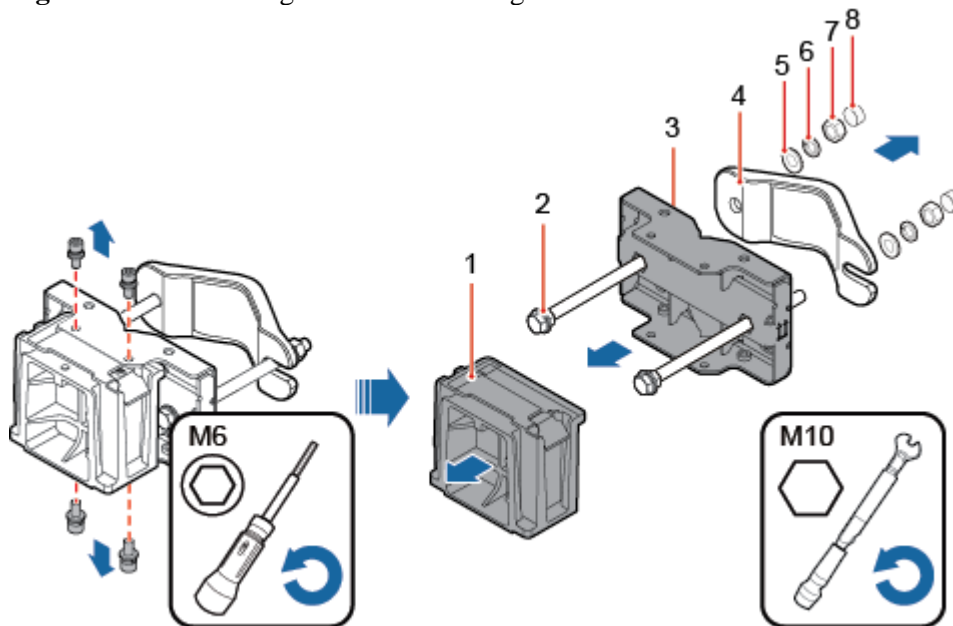

HIR42C0040

- (1) Main bracket (2) Square-neck bolt (3) Pole installation bracket (4) Auxiliary bracket

(5) Flat washer (6) Spring washer (7) Nut (8) Plastic screw cap

- a. Use an M6 inner hexagon torque screwdriver to remove the four inner hexagon screws on the pole installation bracket, and remove the main bracket from the pole installation bracket.
 - b. Use an M10 torque wrench to loosen the nuts on the two square-neck bolts, and remove the plastic screw cap, nuts, spring washers, flat washers, square-neck bolts, and pole installation bracket from the auxiliary bracket.
2. Place the pole installation bracket against the wall, and use a level to verify that the pole installation bracket is placed horizontally, and then mark anchor points with a marker, as shown in [Figure 2](#).

Figure 2 Marking anchor points

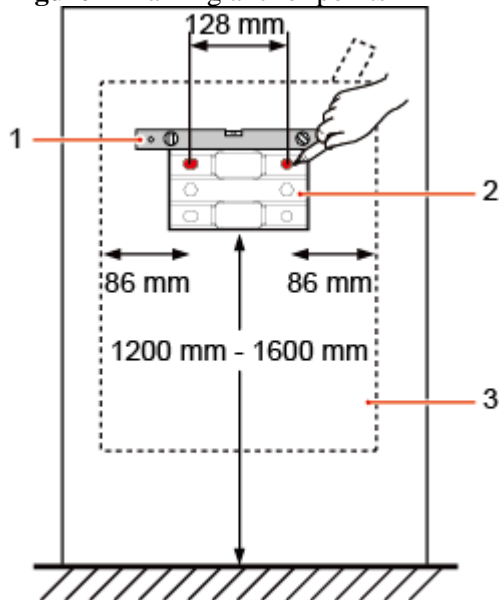

SRR51C0018

(1) Level

(2) Pole installation bracket

(3) RRU

NOTE:

As shown in the figure above, it is recommended that the pole installation bracket be installed at a position 1200 mm (47.24 in.) to 1600 mm (59.06 in.) high above the ground. If the space is insufficient, only the [Installation Clearance Requirements of an RRU](#) needs to be provided.

3. Drill holes at the anchor points, and then insert expansion anchor bolts, as shown in [Figure 3](#).

Figure 3 Drilling holes and inserting expansion anchor bolts

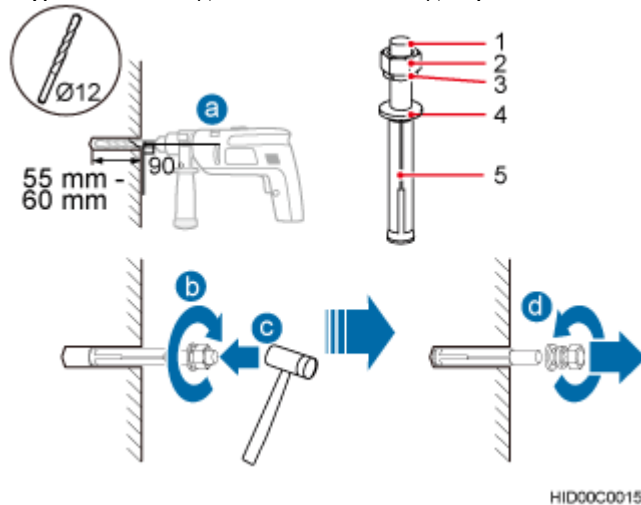

- (1) M10x80 bolt (2) Nut (3) Spring washer (4) Flat washer (5) Expansion sleeve

- a. Use a hammer drill with a $\Phi 12$ bit to drill holes vertically at the marked anchor points with the depth ranging from 55 mm (2.17 in.) to 60 mm (2.36 in.), and use a vacuum cleaner to clear the dust out from inside and around the holes, and measure the distances between holes. If any of the holes is beyond the acceptable range, mark a new anchor point and drill a new hole.

⚠NOTICE:

Take proper safety measures to protect your eyes and respiratory tract against the dust before drilling holes.

- b. Tighten the expansion anchor bolts slightly and place one vertically into each hole.
- c. Use a rubber mallet to pound the expansion anchor bolt until it goes into the hole completely.
- d. Tighten and then loosen the expansion bolt, and remove the M10 nut, spring washer, and flat washer in sequence.

⚠NOTICE:

After dismantling an expansion anchor bolt, ensure that the top of the expansion sleeve is on the same level as the wall. Otherwise, the device cannot be installed on the wall evenly and securely.

4. Install the pole installation bracket on the expansion anchor bolts, place the flat washers, spring washers, and nuts through the expansion anchor bolts in sequence, and then use an M10 torque socket to tighten the nuts to 30 N·m (265.52 lbf·in.), as shown in [Figure 4](#).

Figure 4 Installing the pole installation bracket on the expansion anchor bolts

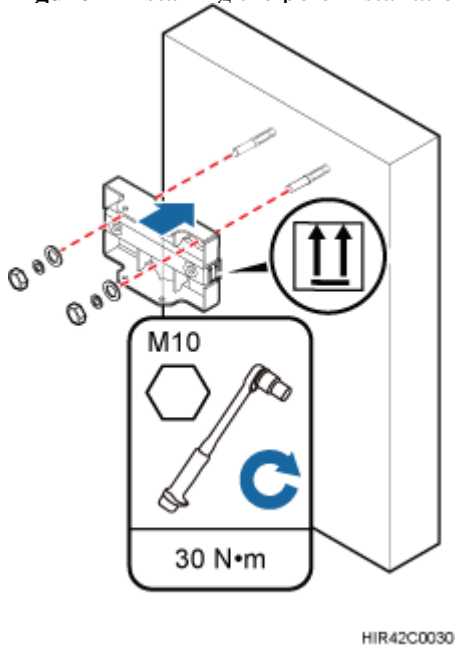

⚠ NOTICE:

Ensure that the arrows on the pole installation bracket are pointing up.

5. Install the main bracket onto the pole installation bracket using four M6x16 inner hexagon screws, and use an inner hexagon torque screwdriver to tighten the inner hexagon screws to 5 N·m (44.25 lbf·in.) so that the main bracket and pole installation bracket are firmly secured, as shown in [Figure 5](#).

Figure 5 Installing the main bracket

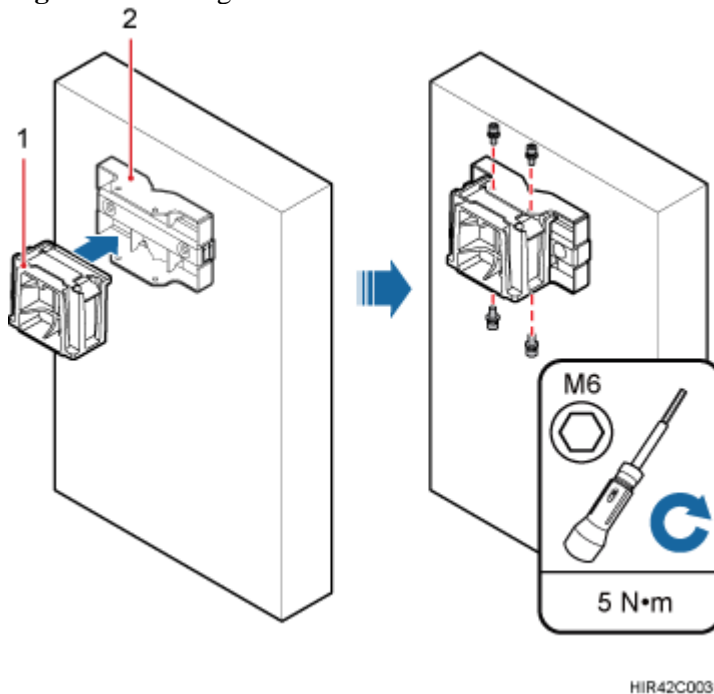

(1) Main bracket

(2) Pole installation bracket

6. Use an inner hexagon torque screwdriver to remove the attachment plate from one side of the RRU, reinstall the attachment plate onto the rear of the RRU, and tighten the four stainless screws to 5 N·m (44.25 lbf·in.), as shown in [Figure 6](#).

Figure 6 Installing the attachment plate onto the rear of the RRU

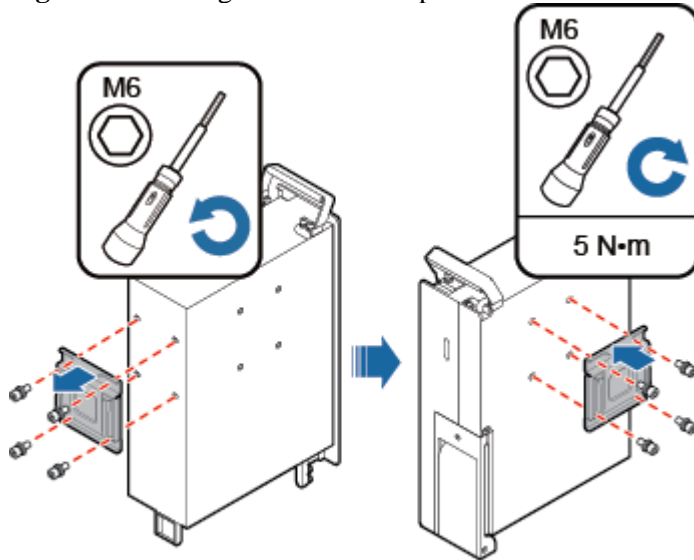

HIA07C0059

7. Install the RRU onto the main bracket, as shown in [Figure 7](#).

Figure 7 Installing the RRU onto the main bracket

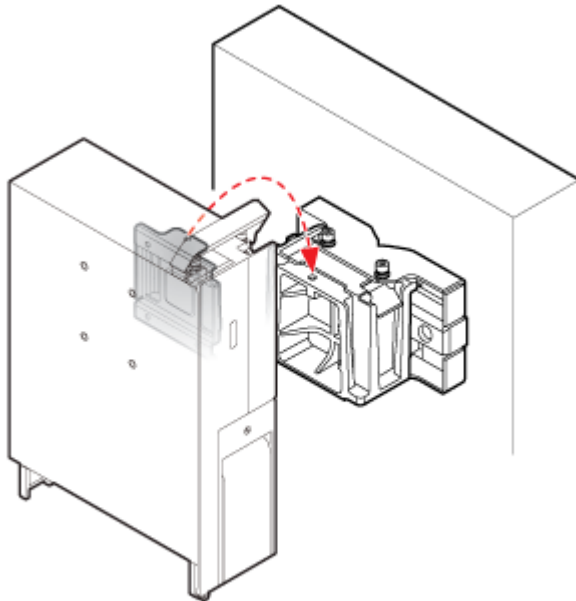

HIRA7C0057

8. Use an inner hexagon torque screwdriver to tighten the captive screw into the holes on the top of the attachment plate and main bracket to 5 N·m (44.25 lbf·in.) so that the attachment plate and main bracket are firmly secured, as shown in [Figure 8](#).

Figure 8 Securing the captive screw into the connection hole

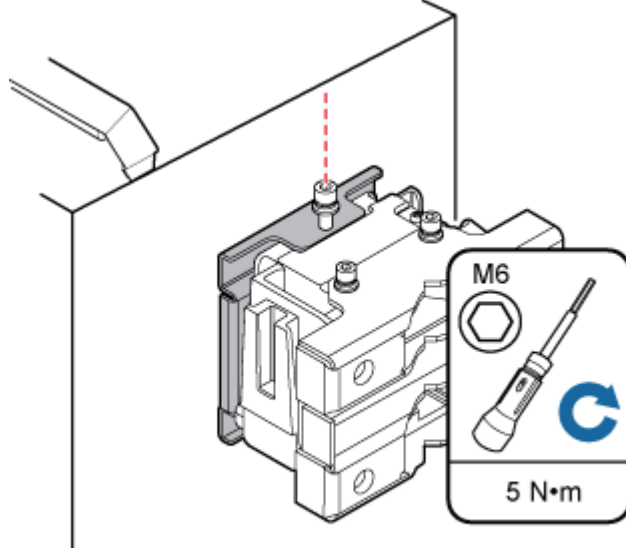

HIR42C0041

Parent Topic: [Installing the RRU](#)

Huawei Proprietary and Confidential Copyright © Huawei Technologies Co., Ltd.

Huawei Proprietary and Confidential

Copyright © Huawei Technologies Co., Ltd.

[< Previous topic](#) [Next topic >](#)

7.2.2.7.6 Installing an RRU on an IFS06

This section describes the process and precautions for installing an [RRU](#) on an IFS06.

Prerequisites

The hoist clamp on the main bracket is secured properly.

NOTICE:

- Do not stand an RRU upright because the [RF](#) ports cannot support the weight of the RRU.
 - Place a foam pad or cardboard under an RRU to protect the RRU housing from damage during the installation.
-

Context

- The upper and lower adjustable beams on an IFS06 can be moved up and down to fit for heights of RRUs.
- RRUs can be installed on an IFS06 when the ambient temperature is higher than or equal to the lowest operating temperature of the RRUs and at least 5°C (41°F) lower than the highest working temperature of the RRU. In this scenario, the IFS06 supports at least three RRUs. The IFS06 supports a maximum of six RRUs when the ambient temperature is higher than or equal to the

lowest operating temperature of the RRUs and at least 10°C (50°F) lower than the highest operating temperature of the RRUs.

NOTE:

For details about the operating temperature of the RRUs, see section "Technical Specifications of RRUs" in *Base Station Technical Description*.

- Install RRUs from bottom to top and from left to right.
- This section describes how to install an RRU in height-unrestricted scenarios. The procedure for installing an RRU in height-restricted scenarios is the same as that in height-unrestricted scenarios.
- When installing the pole mounting kit, use the M10x50 bolts delivered with the IFS06.
- Rubber washers are easily compressed or broken, whereas do not need to be replaced.

Procedure

1. Disassemble the RRU mounting kits, as shown in [Figure 1](#).

Figure 1 Disassembling the RRU mounting kits

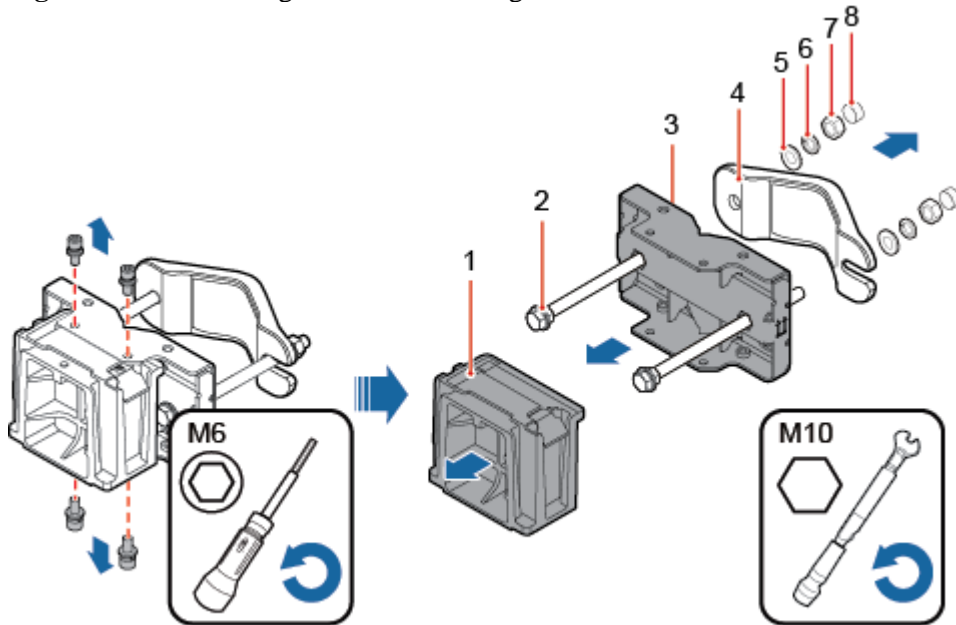

HIR42C0040

- | | | | |
|------------------|----------------------|-------------------------------|-----------------------|
| (1) Main bracket | (2) Square-neck bolt | (3) Pole installation bracket | (4) Auxiliary bracket |
| (5) Flat washer | (6) Spring washer | (7) Nut | (8) Plastic screw cap |

- a. Use an M6 inner hexagon torque screwdriver to remove the four inner hexagon screws on the pole installation bracket, and remove the main bracket from the pole installation bracket.
- b. Use an M10 torque wrench to loosen the nuts on the two square-neck bolts, and remove the plastic screw cap, nuts, spring washers, flat washers, square-neck bolts, and pole installation bracket from the auxiliary bracket.

2. Install the RRU main bracket using the M10x50 bolts delivered with the IFS06. Then tighten the bolts using an M10 torque socket to 30 N·m (265.52 lbf·in.).

⚠NOTICE:

Ensure that the arrows on the pole mounting kits are pointing up.

Install the RRU mounting kits, as shown in [Figure 2](#).

Figure 2 Installing the pole mounting kit in height-unrestricted scenario

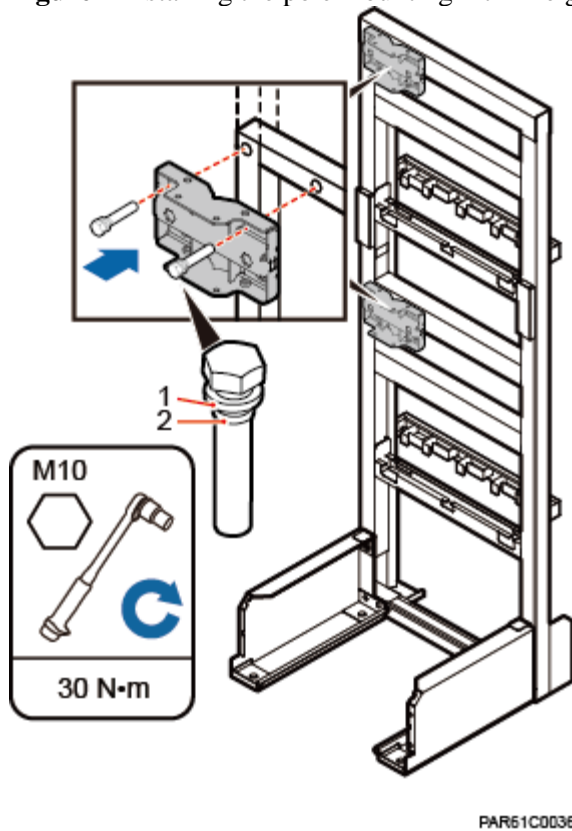

(1) Spring washer

(2) Rubber washer

3. Attach the main bracket to the pole mounting kit, and use an inner hexagon screwdriver to tighten four M6x16 screws to 5 N·m (44.25 lbf·in.) so that the main bracket and pole mounting kit are firmly secured, as shown in [Figure 3](#).

Figure 3 Installing the RRU main brackets

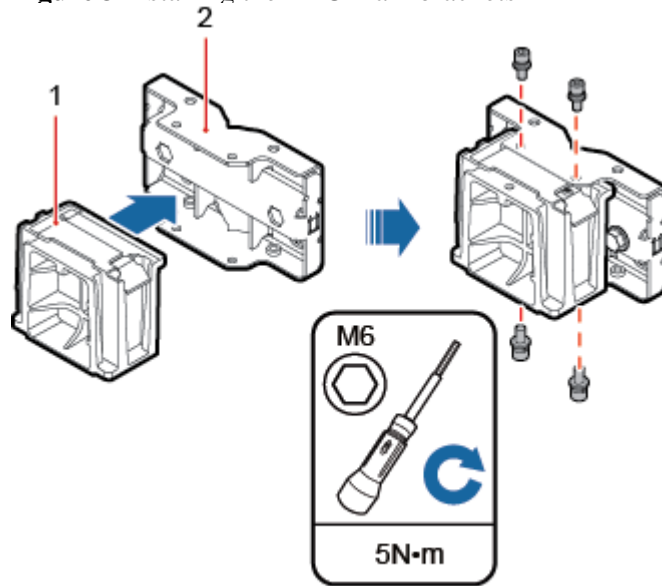

HIR00C0020

(1) Main bracket

(2) Pole mounting kit

4. Attach the RRU to the main bracket, and then use an inner hexagon screwdriver to tighten the captive screw into the holes of the attachment plate and main bracket to 5 N·m (44.25 lbf·in.) so that the attachment plate and main bracket are firmly secured, as shown in [Figure 4](#).

Figure 4 Installing and securing the RRU on the main bracket

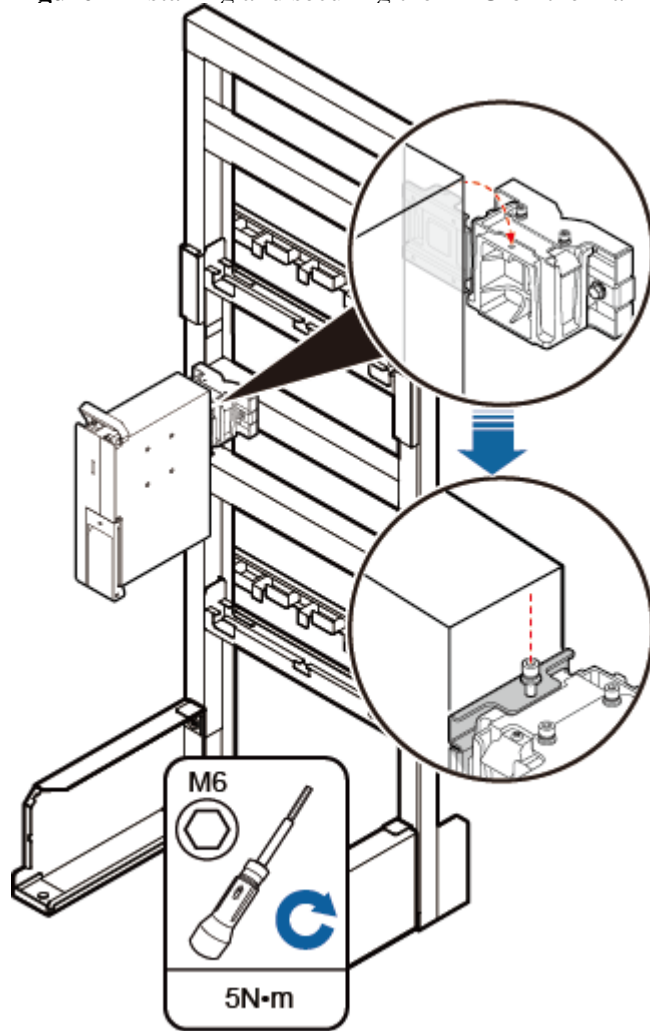

HIRA7C0060

5. Install the RRUs on the lower level from left to right, as shown in [Figure 5](#).

Figure 5 Installing RRUs on the lower level

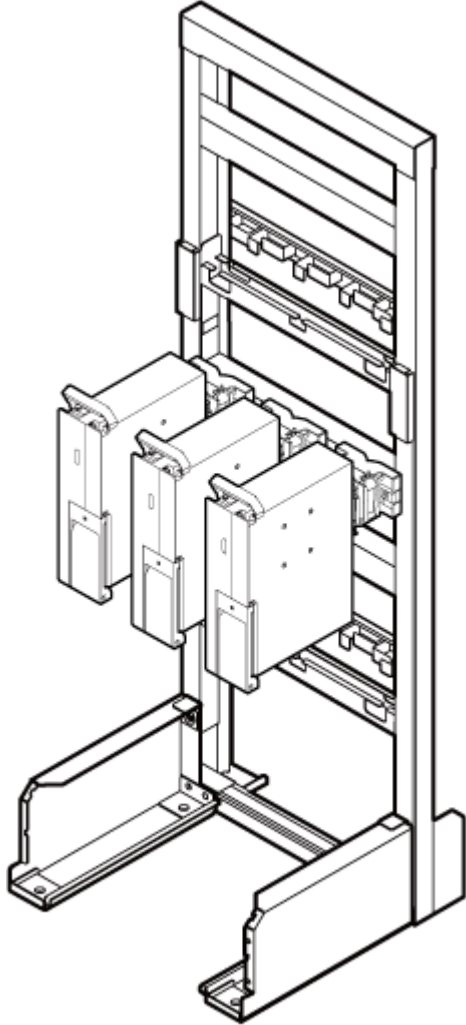

PARA7C0007

6. **Optional:** When the ambient temperature is greater than or equal to the lowest operating temperature of the RRU and at least 10°C (50°F) lower than the highest operating temperature of the RRU, repeat the preceding steps to install the RRUs on the higher level, as shown in [Figure 6](#).

Figure 6 Installing RRUs on the higher level

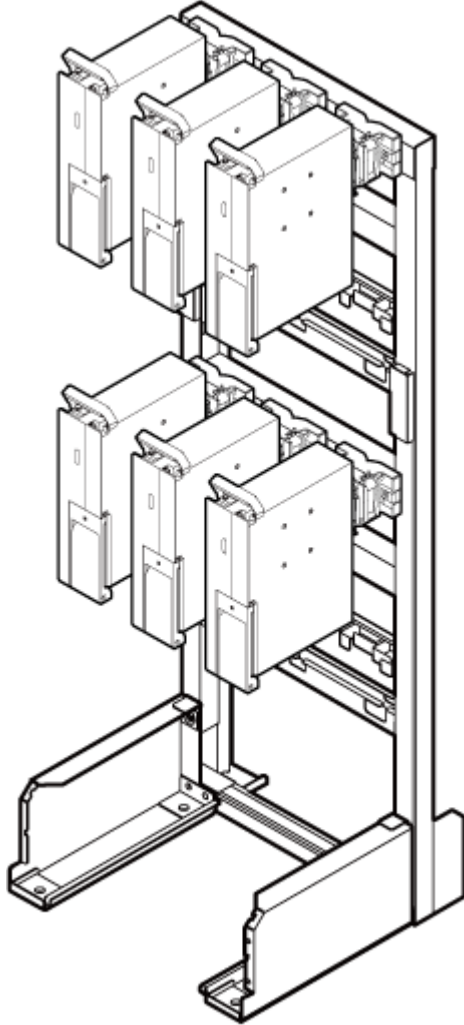

PARA7C0010

Parent Topic: [Installing the RRU](#)

Huawei Proprietary and Confidential Copyright © Huawei Technologies Co., Ltd.

Huawei Proprietary and Confidential

Copyright © Huawei Technologies Co., Ltd.

[< Previous topic](#)

7.2.2.8 Installing RRU Cables

This chapter describes the procedure for installing [RRU](#) cables.

[Cabling Requirements](#)

Cables must be routed according to the specified cabling requirements to prevent signal interference.

[RRU Cable Connections](#)

This section describes RRU cable connections.

[Installing RRU Cables](#)

This chapter describes the procedure for installing RRU cables.

[RRU Cable List](#)

This section describes RRU cable connections.

[Installing an RRU PGND Cable](#)

This section describes the procedure for installing an RRU PGND cable.

[Installing an RRU RF Jumper](#)

This section describes the procedure for installing an RRU RF jumper.

[Installing an RRU AISG Multi-Wire Cable and AISG Extension Cable](#)

This section describes the procedures for installing an RRU AISG multi-wire cable and AISG extension cable.

[Opening the Cover Plate of an RRU Cabling Cavity](#)

This section describes the procedure for opening the cover plate of an RRU cabling cavity.

[Installing a CPRI Optical Fiber](#)

This section describes the procedure for installing a CPRI optical fiber.

[Installing an RRU power cable](#)

This section describes the procedure for installing an RRU power cable.

[Closing the Cover Plate of an RRU Cabling Cavity](#)

This section describes the procedure for closing the cover plate of an RRU cabling cavity.

Huawei Proprietary and Confidential Copyright © Huawei Technologies Co., Ltd.

Huawei Proprietary and Confidential

Copyright © Huawei Technologies Co., Ltd.

[< Previous topic](#) [Next topic >](#)

7.2.2.8.1 Cabling Requirements

Cables must be routed according to the specified cabling requirements to prevent signal interference.



NOTE:

If a cable listed below is not required, skip the cabling requirements of the cable.

General Cabling Requirements

Bending radius requirements

- The bending radius of a 7/8" feeder must be greater than 250 mm (9.84 in.), and the bending radius of a 5/4" feeder must be greater than 380 mm (14.96 in.).
- The bending radius of a 1/4" jumper must be greater than 35 mm (1.38 in.). The bending radius of a super-flexible 1/2" jumper must be greater than 50 mm (1.97 in.), and the bending radius of an ordinary 1/2" jumper must be greater than 127 mm (5 in.).
- The bending radius of a power cable or PGND cable must be at least three times its diameter.

- The bending radius of a fiber optic cable is at least 20 times of its diameter, and the bending radius of a breakout cable is at least 30 mm (1.18 in.).
- The bending radius of an E1/T1 cable must be at least three times its diameter.
- The bending radius of a signal cable must be at least five times its diameter.

Cable binding requirements

- Cables of the same type must be bound together.
- Different types of cables must be separately routed and bound, with a minimum distance of 30 mm (1.18 in.) from each other.
- The cables must be bound tightly and neatly. The sheaths of the cables must not be damaged.
- The cable ties must face the same direction, and those at the same horizontal line must be in a straight line.
- The excess of the indoor cable ties is cut off. The excess of 5 mm (0.2 in.) of the outdoor cable ties is reserved, and the cut surfaces are smooth without sharp edges.
- After cables are installed, labels or nameplates must be attached to the cables at their ends, curves, and interconnection positions.

Security requirements

- When routing cables, avoid sharp objects, for example sharp edges on the wall. If necessary, use tubes to protect the cables.
- When routing cables, keep the cables away from heat sources and use heat insulation materials to insulate the cables from the heat sources.
- Reserve a proper distance (0.1 m or 0.33 ft is recommended) between equipment and cables especially at the cable curves to protect the cables and equipment.

Indoor cabling requirements

- Route each cable into the room through the feeder window.
- Reserve drip loops for all cables outside the feeder window before routing them into the room. Ensure that the radiuses of the drip loops are greater than or equal to the minimum bending radiuses of the cables.
- When routing a cable into the room, ensure that a person is assisting you in the room.
- Apply waterproof treatment to the feeder window.

Outdoor Cabling Requirements

- After being connected to a ground clip on power cables, a ground cable must be routed downwards to prevent water from entering the equipment to which the power cables connect.
- Protect outdoor cables against potential damage. For example, put the cables through tubes.
- The cables to be protected include AC power cables, transmission cables, and cables routed underground.

- When routing cables through tubes on the ground below the cabinet, put a 30 mm to 50 mm (1.18 in. to 1.97 in.) length of the tubes into the base of the cabinet but do not put the tubes into the cabinet. Use waterproof tape or waterproof silicon gel to block both ends of the tubes and use sheet metal tabs to secure the tubes to the cable holes in the base.
- When routing cables through tubes along a metal cable trough below the cabinet, do not put the tubes into the base of the cabinet but cover the cable trough and connect the tubes to the cable holes in the base.
- When routing RRU cables, ensure that the highest positions of the routes of all RRU cables (except RF cables and AISG cables) are lower than the bottom of the RRU to prevent water from entering the maintenance cavity of the RRU.
- Use clips to secure cables outdoors. For the method of installing a clip, see the installation guide delivered with the clip.
- Arrange cables neatly along the routing direction and use clips to secure the cables.
- Determine the positions where the clips are installed according to the actual situation. For example, 7/8" feeders are secured with clips at an interval of 1.5 m to 2 m (4.92 ft to 6.56 ft), CPRI fiber optic cables and power cables are secured with clips at an interval of 1 m to 1.5 m (3.28 ft to 4.92 ft). Ensure that the clips are evenly spaced and in the same direction.
- When fastening cables with a clip, ensure that the cables are aligned neatly and are routed through the holes in the clip. Do not stretch the cables too tightly.

 **NOTE:**

There are two types of clips: 3-hole clip and 6-hole clip, which are described as follows:

- A 3-hole clip is shown by illustration a in the following figure. It is often used to fasten feeders.
 - A 6-hole clip is shown by illustration b in the following figure. It is often used to fasten power cables and CPRI fiber optic cables.
-

Figure 1 Exterior of the clips

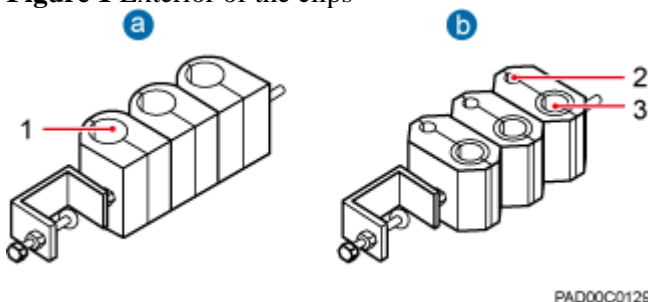

(1) Cable hole for feeders (2) Cable hole for CPRI fiber optic cables (3) Cable hole for power cables

The following figure shows the cables secured on a cable tray.

Figure 2 Cables secured on a cable tray

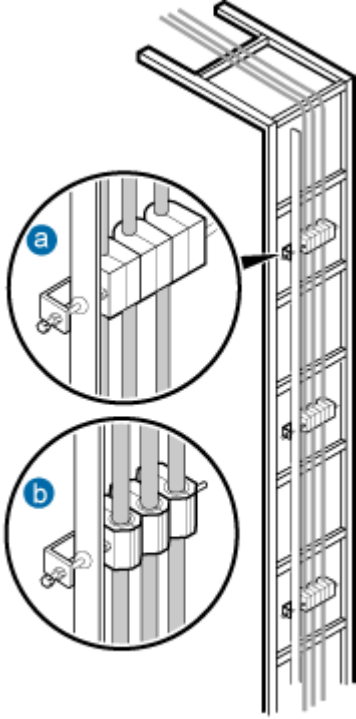

SRD00C1001

(1) 3-hole clip

(2) 6-hole clip

The following figure shows the cables secured on a tower.

Figure 3 Cables secured on a tower

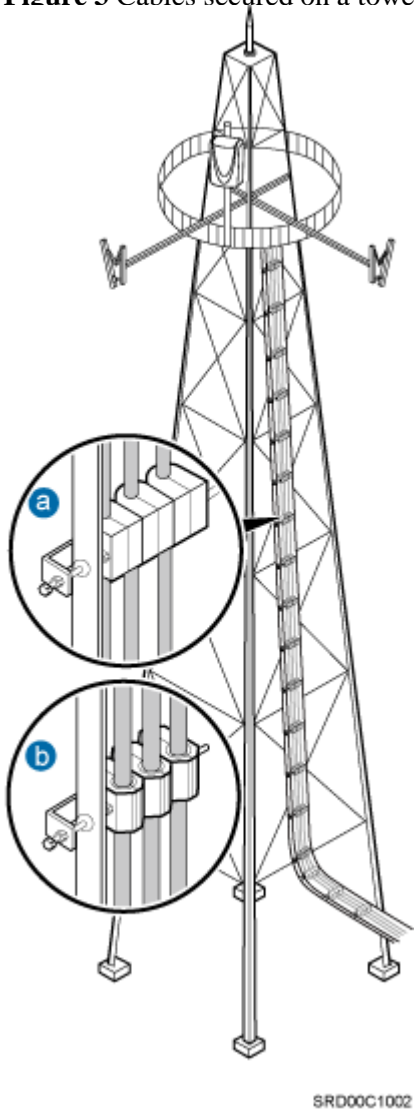

(1) 3-hole clip

(2) 6-hole clip

Special Cabling Requirements

Cabling of power cables

- Power cables must be installed in the position specified in engineering design documents.
- If the length of power cables is insufficient, replace the cables rather than adding connectors or soldering joints to lengthen the cables.
- Cables can only be routed under well-planned instructions. The cabling activities of fiber optic cables are allowed only when qualified personnel and communication facilities are available.
- Do not circle and twist cables.
- After routing a **DC** power cable onto the platform on a tower, route it along the shortest path to the rails surrounding the platform, and route it along the inside of the rails.

- After routing a DC power cable close to the equipment on a tower, use clips to secure the power cable onto a pole or the rails surrounding the platform. Ensure that there is no excessively long distance between the equipment and the position where the power cable is secured.

Cabling of PGND cables

- PGND cables for a base station must be connected to the same group of ground bars.
- PGND cables must be buried in the ground or routed indoors.
- The external conductor of the coaxial wire and the shield layer of the shielded cable must have proper electrical contact with the metal surface of the equipment to which they are connected.
- PGND cables and signal cables must be installed separately. A certain distance must be reserved between them to prevent interference from each other.
- Switches or fuses must not be installed on the PGND cables.
- Other devices must not be used for electrical connections of the PGND cables.
- All the metal parts in the housing of the equipment must be reliably connected to the ground terminal.

Cabling of E1 cables

- E1 cables must not cross power cables, PGND cables, or RF cables when routed. If transmission cables are routed with power cables, PGND cables, or RF cables in parallel, the spacing between them must be greater than 30 mm (1.18 in.).
- E1 cables are lined up straight and bound neatly with cable ties.
- Sufficient slack is provided for E1 cables at turns.
- E1 cables must not be pressed by the door of the cabinet when routed, as shown in the following figure.

Figure 4 E1 cables routed in the cabinet

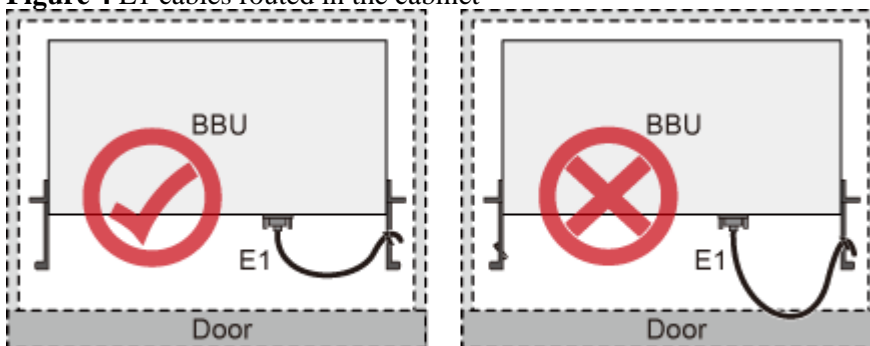

CIH00C4013

Cabling of fiber optic cables

- At least three people are required for laying out fiber optic cables. The cabling activities of fiber optic cables are allowed only when qualified personnel and communication facilities are available.

- The operating temperature of fiber optic cables ranges from -40°C to $+60^{\circ}\text{C}$ (-40°F to $+140^{\circ}\text{F}$). If the actual temperature is beyond this range, take protective measures or select another route.
- Do not circle and twist cables.
- Do not bind a fiber optic cable at the position where it bends.
- Do not stretch, step on, or place heavy objects on fiber optic cables. Keep the fiber optic cables away from sharp objects.
- When fiber optic cables are routed, the excess of the fiber optic cables must be coiled around special devices, such as a fiber coiler.
- An unarmored fiber optic cable must be bound using binding straps. If a fiber optic patch cord needs to be secured in a cabinet or a piece of equipment, use binding straps to bind it and then use cable ties to secure the binding straps to the cabinet or equipment. Ensure that the fiber optic cables can flexibly move in the cable ties. Do not bend the fiber optic cables sharply. The following figure shows how to bind the fiber optic cables correctly.

Figure 5 Binding fiber optic cables

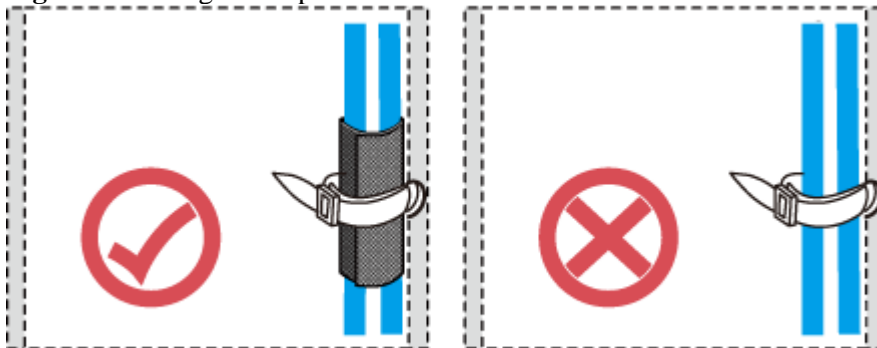

CIH00C4014

- When coiling fiber optic cables, apply even strength. Do not bend the fiber optic cables with force.
- Unused optical connectors must be covered with dustproof caps.
- The fiber optic cables must not be pressed by the door of the cabinet when routed, as shown in the following figures.

Figure 6 CPRI fiber optic cables routed in the cabinet (1)

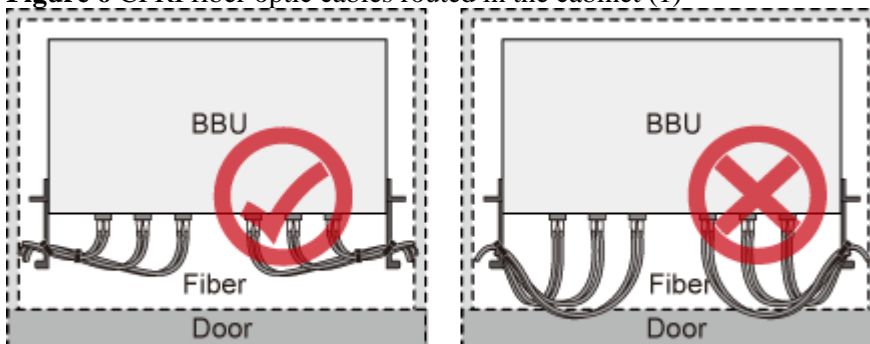

CIH00C4008

Figure 7 CPRI fiber optic cables routed in the cabinet (2)

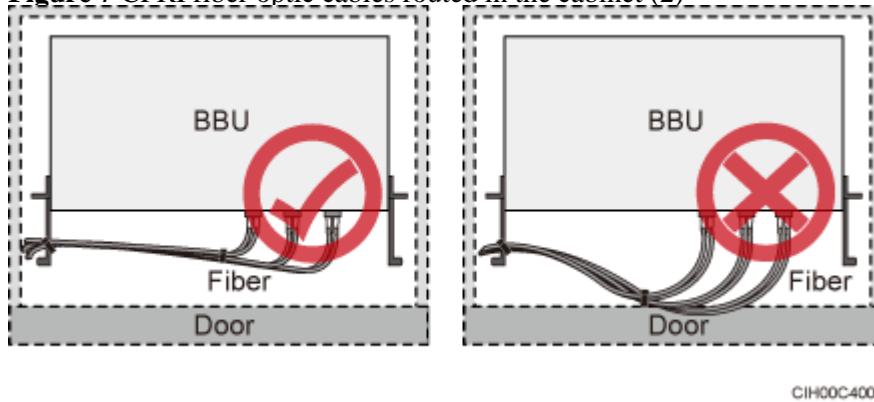
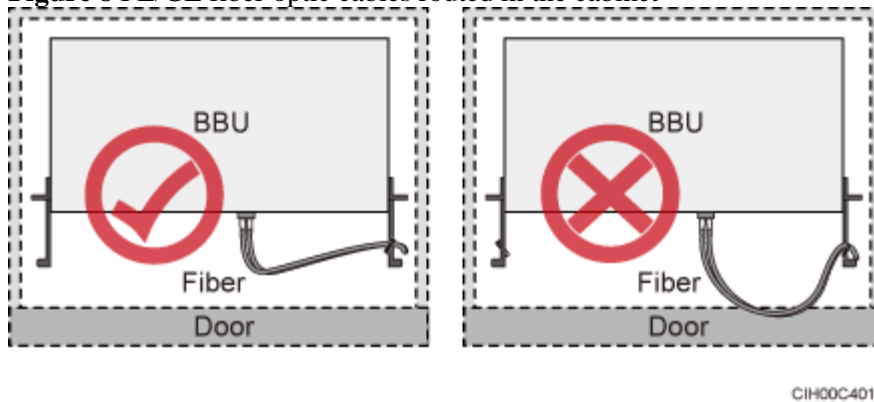

Figure 8 FE/GE fiber optic cables routed in the cabinet



- After routing a fiber optic cable onto the platform on a tower, route it along the shortest path to the rails surrounding the platform, and route it along the inside of the rails.
- After routing a fiber optic cable close to the equipment on a tower, use clips to secure the fiber optic cable onto a pole or the rails surrounding the platform. Ensure that there is no excessively long distance between the equipment and the position where the cable is secured.
- Coil the excess of the fiber optic cables near the equipment on the tower before securing the cables on the tower.

Parent Topic: [Installing Cables](#)

Huawei Proprietary and Confidential Copyright © Huawei Technologies Co., Ltd.

Huawei Proprietary and Confidential

Copyright © Huawei Technologies Co., Ltd.

[Next topic >](#)

7.2.2.8.2 RRU Cable Connections

This section describes [RRU](#) cable connections.

 **NOTE:**

The RRU does not support power cable cascading.

[Figure 1](#) and [Figure 2](#) show the cable connections of a single-mode RRU.

 **NOTE:**

When the following scenarios need to be monitored by RRUs,

- If the external power supply system needs to be monitored and supports modulating RS485 and dry contact alarm signals using power cables, you do not need to install the MEB.
- In other scenarios, you need to install MEB. For details about MEB and MEB cable installation, see *MEB06D User Guide*.

Figure 1 Cable connections of a single-mode RRU (MEB not installed)

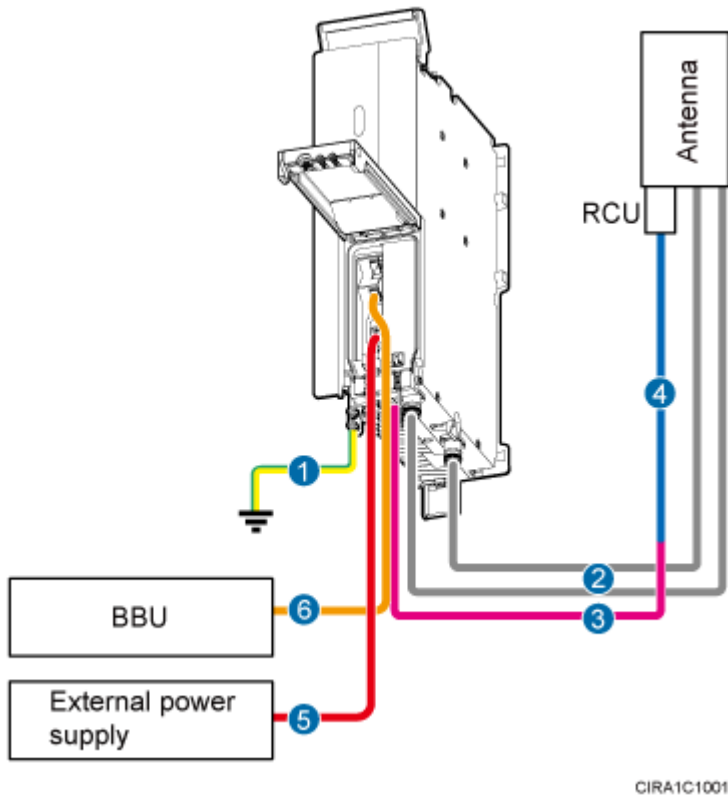

(1) RRU PGND cable

(2) RRU RF jumper

(3) RRU AISG multi-wire cable

(4) RRU AISG extension cable

(5) RRU power cable

(6) CPRI optical fiber

Figure 3 shows the cable connections of a multimode RRU (called)

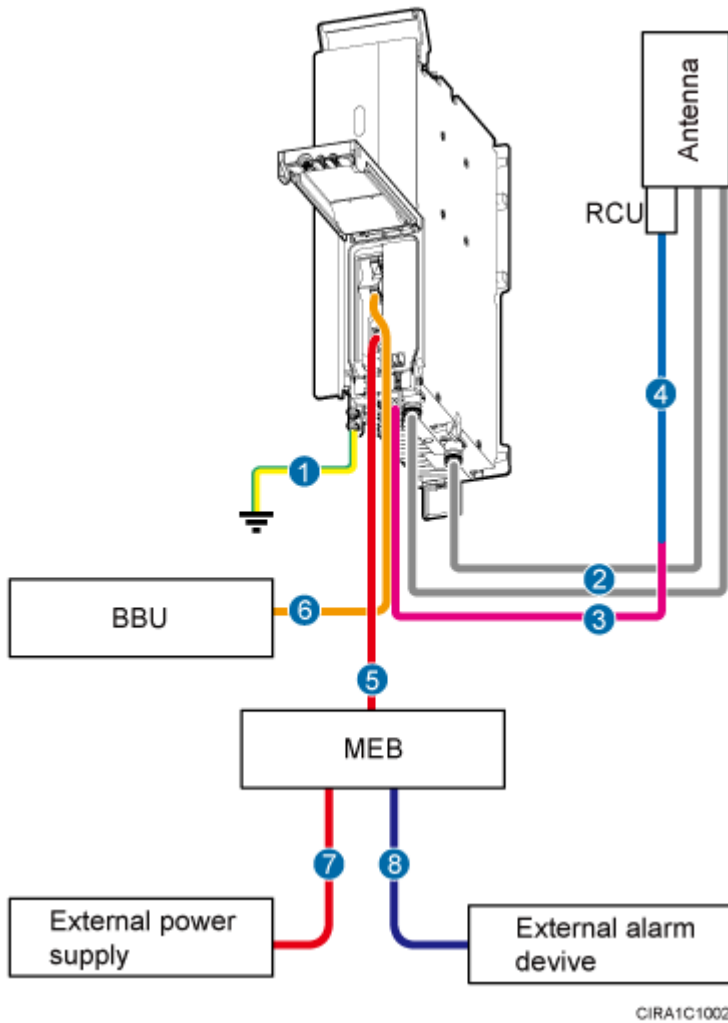

(1) RRU PGND cable

(2) RRU RF jumper

(3) RRU AISG multi-wire cable

(4) RRU AISG extension cable

(5) RRU power cable

(6) CPRI optical fiber

(7) MEB power cable

(8) MEB alarm cable

-

[Figure 3](#) shows the cable connections of a multimode RRU.

 **NOTE:**

RRU5309 and RRU5309w are not supported in multimode scenarios.

Figure 3 Cable connections of a multimode RRU

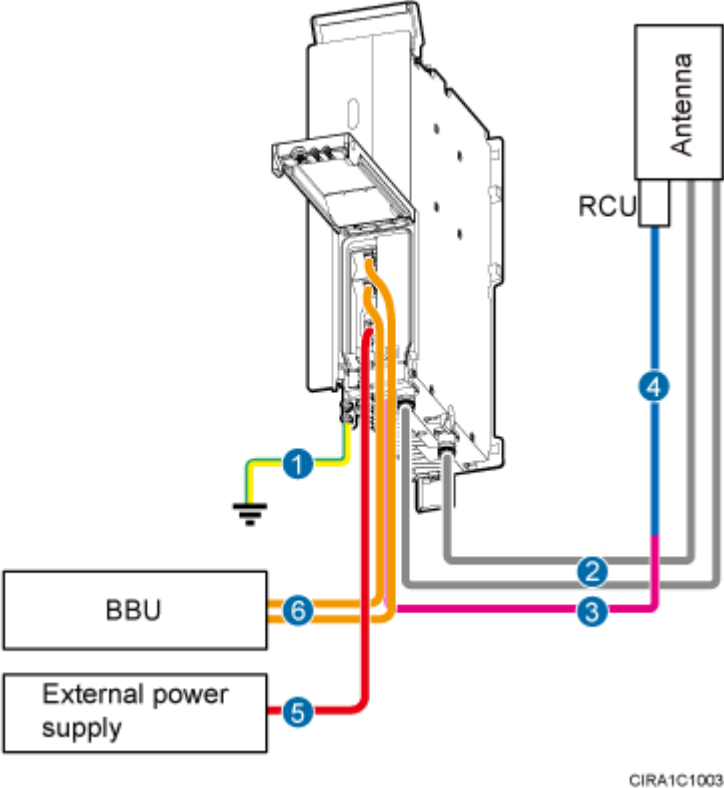

- (1) RRU PGND cable
- (2) RRU RF jumper
- (3) RRU AISG multi-wire cable
- (4) RRU AISG extension cable
- (5) RRU power cable
- (6) CPRI optical fiber

[Figure 4](#) shows the cable connections of multiple single-mode RRUs.

Figure 4 Cable connections of multiple single-mode RRUs

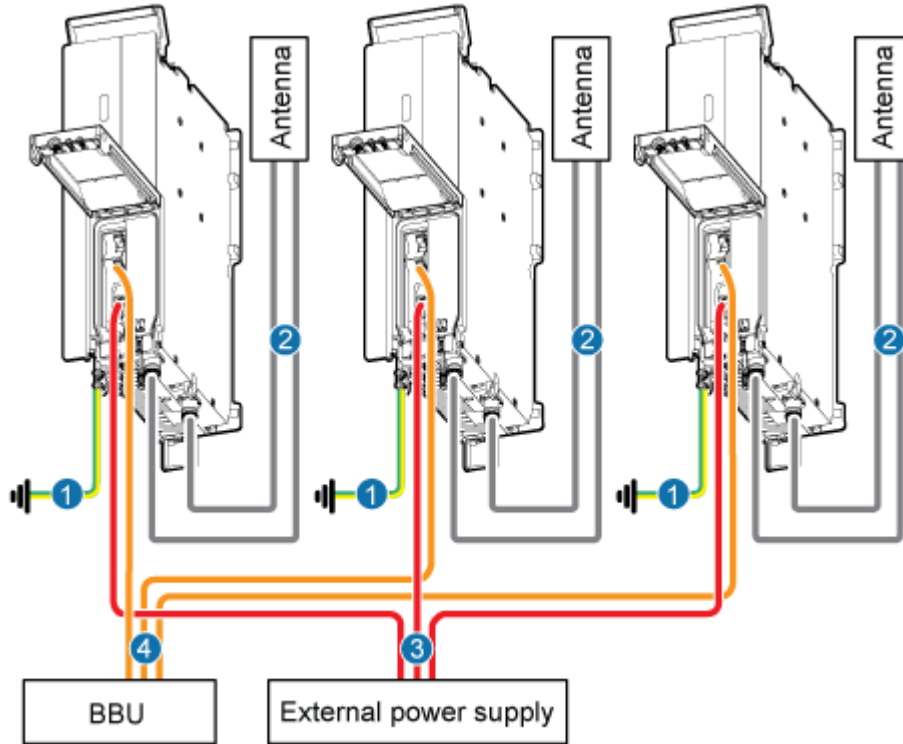

CIRA1C1005

- | | | |
|------------------------|-------------------|---------------------|
| (1) RRU PGND cable | (2) RRU RF jumper | (3) RRU power cable |
| (4) CPRI optical fiber | - | - |

Parent Topic: [Installing RRU Cables](#)

Huawei Proprietary and Confidential Copyright © Huawei Technologies Co., Ltd.

Huawei Proprietary and Confidential

Copyright © Huawei Technologies Co., Ltd.

[< Previous topic](#) [Next topic >](#)

7.2.2.8.3 Installing RRU Cables

This chapter describes the procedure for installing [RRU](#) cables.

[Figure 1](#) shows the procedure for installing RRU cables.

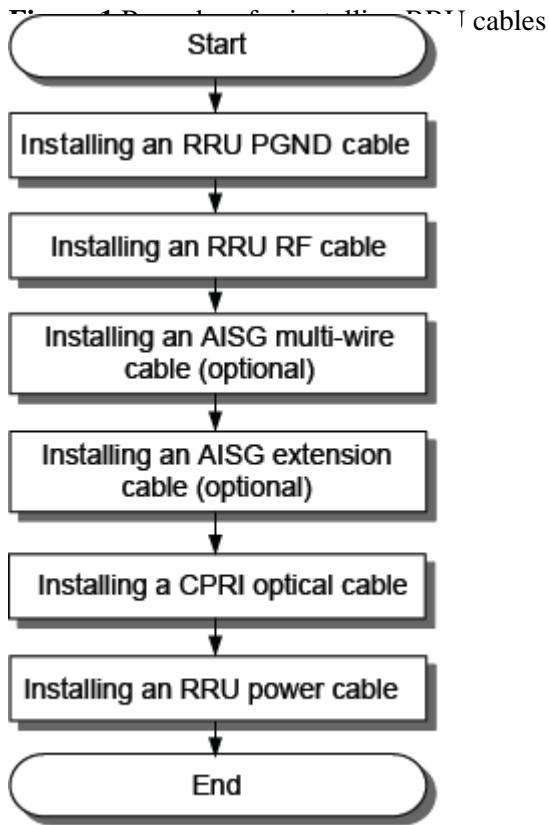

PARA1CG10

Parent Topic: [Installing RRU Cables](#)

Huawei Proprietary and Confidential Copyright © Huawei Technologies Co., Ltd.

Huawei Proprietary and Confidential

Copyright © Huawei Technologies Co., Ltd.

[< Previous topic](#) [Next topic >](#)

7.2.2.8.4 RRU Cable List

This section describes [RRU](#) cable connections.

[Table 1](#) lists RRU cables.

Table 1 RRU cables

Cable	One End		The Other End	
	Connector	Installation Position	Connector	Installation Position
RRU PGND Cable	OT terminal (M6, 16 mm ² or 0.025 in. ²)	Ground terminal on the RRU	OT terminal (M8, 16 mm ² or 0.025 in. ²)	Ground terminal on the ground bar
RRU Power Cable	Female fast connector (pressfit type)	NEG(-) and RTN(+) ports on the RRU	Depending on the power supply equipment	External power equipment
CPRI Fiber Optic Cable	DLC connector	CPRI0 port on the RRU	DLC connector	CPRI port on a board in the BBU or CPRI1 port on the upper-level RRU
		CPRI1 port on the RRU		CPRI0 port on the lower-level RRU or CPRI port on a board in the BBU
RRU RF Jumper	4.3-10 male connector	RF ports on the RRU	4.3-10 male connector or DIN male connector NOTICE: Select cables based on the type of the connector at the other end of the cable on live networks.	Antenna system
RRU AISG Multi-Wire Cable	DB9 waterproof male connector	RET port on the RRU	Standard AISG female connector	Standard AISG male connector on the RCU or on the AISG extension cable
RRU AISG Extension Cable	Standard AISG male connector	Standard AISG female connector on the AISG multi-wire cable	Standard AISG female connector	Standard AISG male connector on the RCU

Parent Topic: [RRU Cables](#)

Huawei Proprietary and Confidential Copyright © Huawei Technologies Co., Ltd.

7.2.2.8.5 Installing an RRU PGND Cable

This section describes the procedure for installing an [RRU](#) PGND cable.

Context

The cross-sectional area of an RRU PGND cable is 16 mm² (0.025 in.²). The cable has an M6 OT terminal at one end and an M8 terminal at the other end.



DANGER:

Install RRU PGND cables by strictly following the following operations. Otherwise, damage to the RRU or personal injury may occur.

Procedure

1. According to the actual cable route, cut the PGND cable into a proper length to prepare an RRU PGND cable. Then, add an OT terminal at each end of the cable according to the instructions in [Assembling the OT Terminal and the Power Cable](#).
2. Install the RRU PGND cable.

Connect the M6 OT terminal at one end of the PGND cable to the ground terminal at the RRU bottom and the M8 OT terminal at the other end to the external ground bar, as shown in [Figure 1](#).

Figure 1 Installing an RRU PGND cable

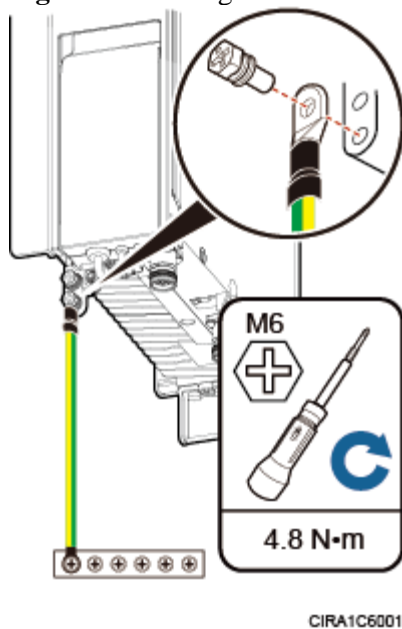

NOTE:

Crimp OT terminals in correct positions, as shown in [Figure 2](#).

Figure 2 Correct position of an OT terminal

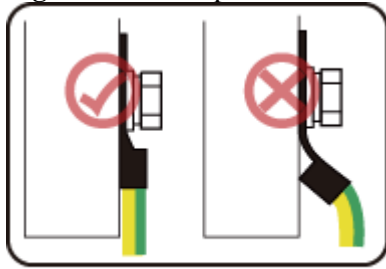

EIR22C6001

3. Label the installed cables according to the instructions in [Attaching a Cable-Tying Label](#).

Parent Topic: [Installing RRU Cables](#)

Huawei Proprietary and Confidential Copyright © Huawei Technologies Co., Ltd.

Huawei Proprietary and Confidential

Copyright © Huawei Technologies Co., Ltd.

[< Previous topic](#) [Next topic >](#)

7.2.2.8.6 Installing an RRU RF Jumper

This section describes the procedure for installing an [RRU RF](#) jumper.

Context

For details about connections between RRU ports and antenna ports, see the RF cable connection section for the corresponding RRU in *RRU Hardware Description*.

Procedure

1. Connect the 4.3-10 straight male connector on the RRU RF jumper to the antenna port, and use a torque wrench to tighten the connector to 5 N·m (44.25 lbf·in.) to 15 N·m (132.74 lbf·in.), as shown in [Figure 1](#).

Figure 1 Installing an RRU RF jumper

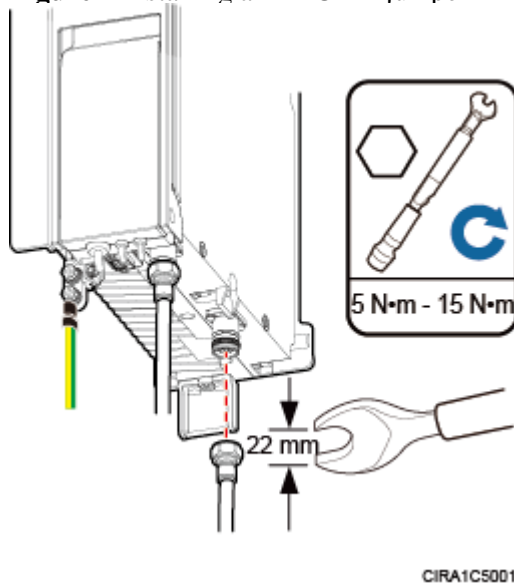

⚠ NOTICE:

On AC-powered electric railways, such as high-speed railways, when leaky cables are connected to RRUs installed in tunnels, high-voltage-resistance DC blocks must be installed between RRU RF jumpers and the leaky cables to protect the RRUs against damage.

2. Connect the other end of the RRU RF jumper to the external antenna system.
-

⚠ NOTICE:

Before installation, check whether the connector at the other end is a 4.3-10 straight male connector or DIN male connector.

3. Waterproof the connectors of the RF jumper by referring to [Figure 2](#).

Figure 2 Waterproofing a connector of the RF jumper

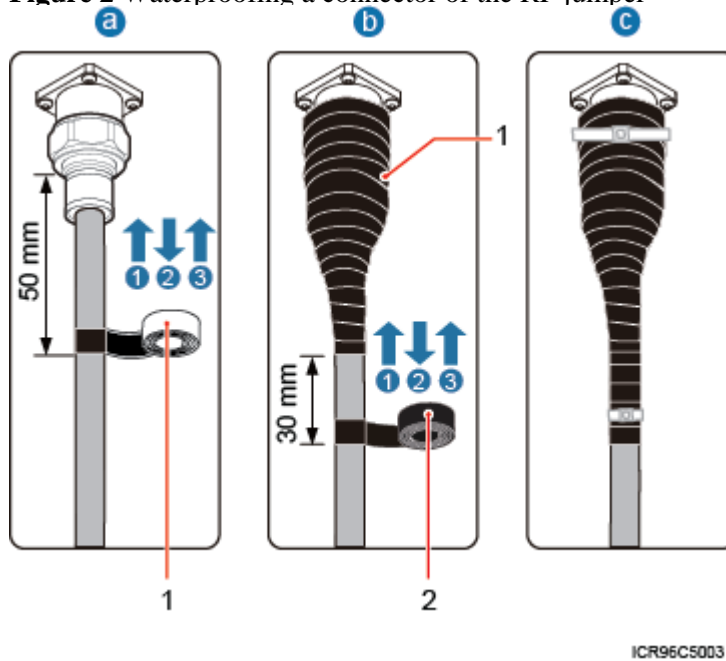

(1) Waterproof tape

(2) PVC insulation tape

NOTE:

- Before wrapping waterproof tape, stretch the tape evenly until the length of the tape becomes twice its original length.
- Do not stretch the PVC insulation tape when wrapping the PVC insulation tape.
- Wrap each layer of tape around the connector tightly and neatly, and ensure that each layer of tape overlaps more than 50% of the preceding layer. Ensure that neighboring layers are stuck to each other.
- Ensure that the adhesive surface of the tape overlaps the lower layer.
- When cutting off the cable ties, reserve a redundant length of 3 mm (0.12 in.) to 5 mm (0.2 in.).

- f. Wrap three layers of waterproof tape on the connector, first from bottom up, then from top down, and finally from bottom up. Start wrapping the connector at a position 50 mm (1.97 in.) away below the bottom of the connector to the top of the connector, first from bottom up, then from top down, and finally from bottom up. Cut off the redundant tape after three layers are wrapped. Wrap each layer of tape around the connector tightly.
 - g. Wrap three layers of PVC insulation tape. Start the wrapping at a position 30 mm (1.18 in.) away below the bottom of the waterproof tape to the top of the connector, first from bottom up, then from top down, and finally from bottom up. Cut off the redundant tape after three layers are wrapped. Wrap each layer of tape around the connector tightly.
 - h. Start binding cable ties to the cable at a position 3 mm (0.12 in.) to 5 mm (0.2 in.) away from one end of the PVC insulation tape.
4. Check the dustproof caps on antenna connectors. In outdoor scenarios, dustproof caps must be waterproofed, as shown in [Figure 3](#).

NOTICE:

Do not remove dustproof caps from vacant antenna connectors.

Figure 3 Waterproofing a dustproof cap

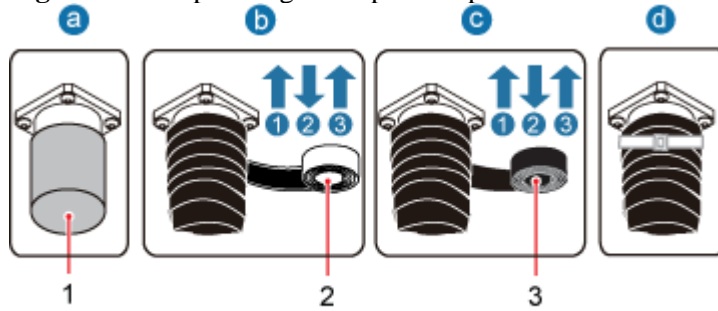

ICR06C5008

(1) Dustproof cap

(2) Waterproof tape

(3) PVC insulation tape

NOTE:

- Before wrapping waterproof tape, stretch the tape evenly until the length of the tape becomes twice its original length.
- Do not stretch the PVC insulation tape when wrapping the PVC insulation tape.
- Wrap each layer of tape around the connector tightly and neatly, and ensure that each layer of tape overlaps more than 50% of the preceding layer. Ensure that neighboring layers are stuck to each other.
- Ensure that the adhesive surface of the tape overlaps the lower layer.
- When cutting off the cable ties, reserve a redundant length of 3 mm (0.12 in.) to 5 mm (0.2 in.).

- e. Verify that dustproof caps are not removed.
 - f. Wrap three layers of waterproof tape on the connector, first from bottom up, then from top down, and finally from bottom up. Wrap each connector with three layers of waterproof tape, from bottom up, then from top down, and finally from bottom up. Do not cut the tape until all the three layers of the tape are already wrapped. Cut off the redundant tape after three layers are wrapped. Wrap each layer of tape around the connector tightly.
 - g. Wrap three layers of PVC insulation tape. Wrap each connector with three layers of waterproof tape, from bottom up, then from top down, and finally from bottom up. Do not cut the tape until all the three layers of the tape are already wrapped. Cut off the redundant tape after three layers are wrapped. Wrap each layer of tape around the connector tightly.
 - h. Start binding cable ties to the cable at a position 3 mm (0.12 in.) to 5 mm (0.2 in.) away from one end of the PVC insulation tape.
5. Route the cables according to the instructions in [Cabling Requirements](#).
 6. Label the installed cables according to the instructions in [Attaching a Sign Plate Label](#).
 7. Attach color-coding to the installed RF jumper according to the instructions in [Attaching the Color Ring](#).

Parent Topic: [Installing RRU Cables](#)

Huawei Proprietary and Confidential Copyright © Huawei Technologies Co., Ltd.

Huawei Proprietary and Confidential

Copyright © Huawei Technologies Co., Ltd.

[< Previous topic](#) [Next topic >](#)

7.2.2.8.7 Installing an RRU AISG Multi-Wire Cable and AISG Extension Cable

This section describes the procedures for installing an [RRU AISG](#) multi-wire cable and AISG extension cable.

Context

When the distance between an RRU and a Remote Control Unit (RCU) is longer than 5 m (16.4 ft.), an AISG multi-wire cable is not long enough to connect the RRU and the [RCU](#). In this case, an AISG extension cable is used to extend the AISG multi-wire cable.

Procedure

- Install an AISG multi-wire cable that is not configured with an AISG extension cable.
 1. Use an M3 flat-head screwdriver to loosen the screws on the dustproof cap on the [RET](#) port and remove the dustproof cap.
 2. Link the waterproofed DB9 connector at one end of the AISG multi-wire cable to the RET port on the RRU bottom, as shown in [Figure 1](#).

Figure 1 Installing an RRU AISG multi-wire cable

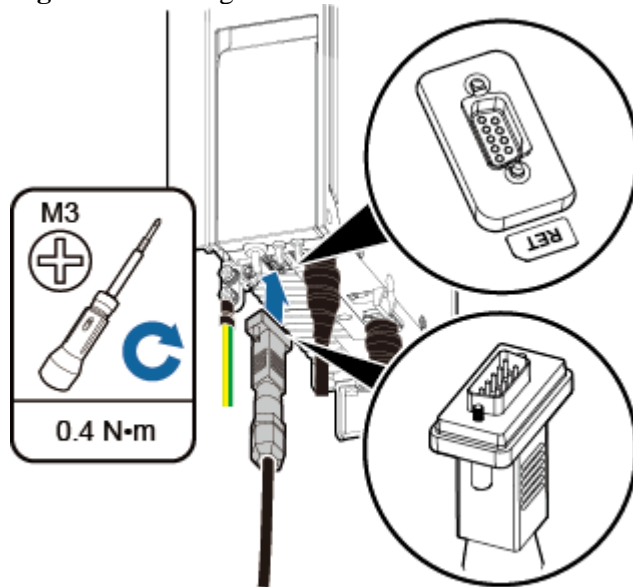

CIRA1C5003

3. Use an M3 Phillips screwdriver to tighten the posts on both sides of the waterproof DB9 connector to 0.4 N·m (3.54 lbf·in.).
4. Connect the other end of the cable to the standard AISG male connector on the RCU.
5. Route the cables according to the instructions in [Cabling Requirements](#).

6. Label the installed cables according to the instructions in [Attaching an L-Shaped Label](#).
- Install an AISG multi-wire cable that is configured with an AISG extension cable.
 1. Use an M3 flat-head screwdriver to loosen the screws on the dustproof cap on the RET port and remove the dustproof cap.
 2. Link the waterproofed DB9 connector at one end of the AISG multi-wire cable to the RET port on the RRU bottom, and link the other end to the standard AISG male connector of the AISG extension cable, as shown in [Figure 2](#).

Figure 2 Installing an RRU AISG multi-wire cable

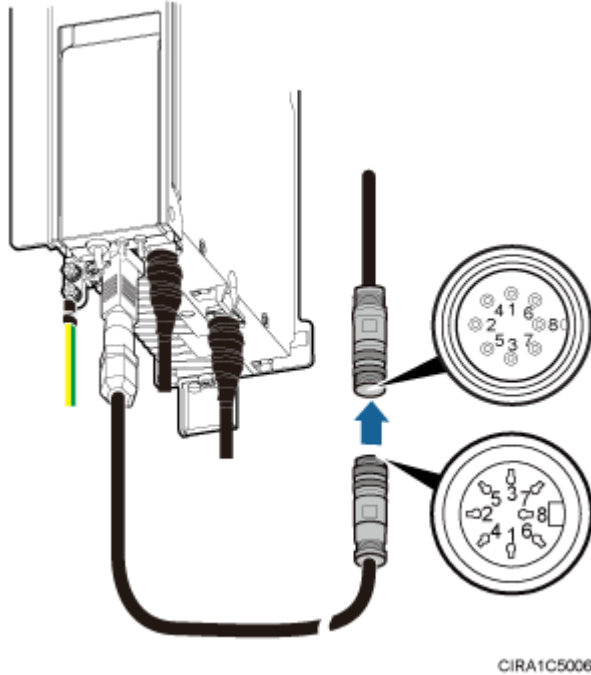

3. Use an M3 Phillips screwdriver to tighten the posts on both sides of the waterproof DB9 connector to 0.4 N·m (3.54 lbf·in.).
4. Connect the other end of the AISG extension cable to the standard AISG male connector on the RCU, as shown in [Figure 3](#).

Figure 3 Installing an RRU AISG extension cable

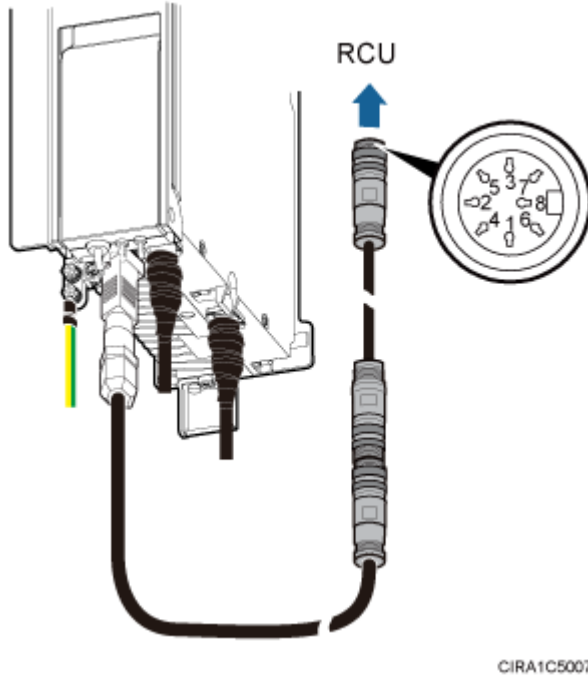

CIRA1C5007

5. Waterproof the joint of the AISG multi-wire cable and AISG extension cable.

 **NOTE:**

- Before wrapping waterproof tape, stretch the tape evenly until the length of the tape becomes twice its original length.
 - Do not stretch the PVC insulation tape when wrapping the PVC insulation tape.
 - Wrap each layer of tape around the connector tightly and neatly, and ensure that each layer of tape overlaps more than 50% of the preceding layer. Ensure that neighboring layers are stuck to each other.
 - Ensure that the adhesive surface of the tape overlaps the lower layer.
 - When cutting off the cable ties, reserve a redundant length of 3 mm (0.12 in.) to 5 mm (0.2 in.).
-

Figure 4 Waterproofing the connector on the AISG multi-wire cable

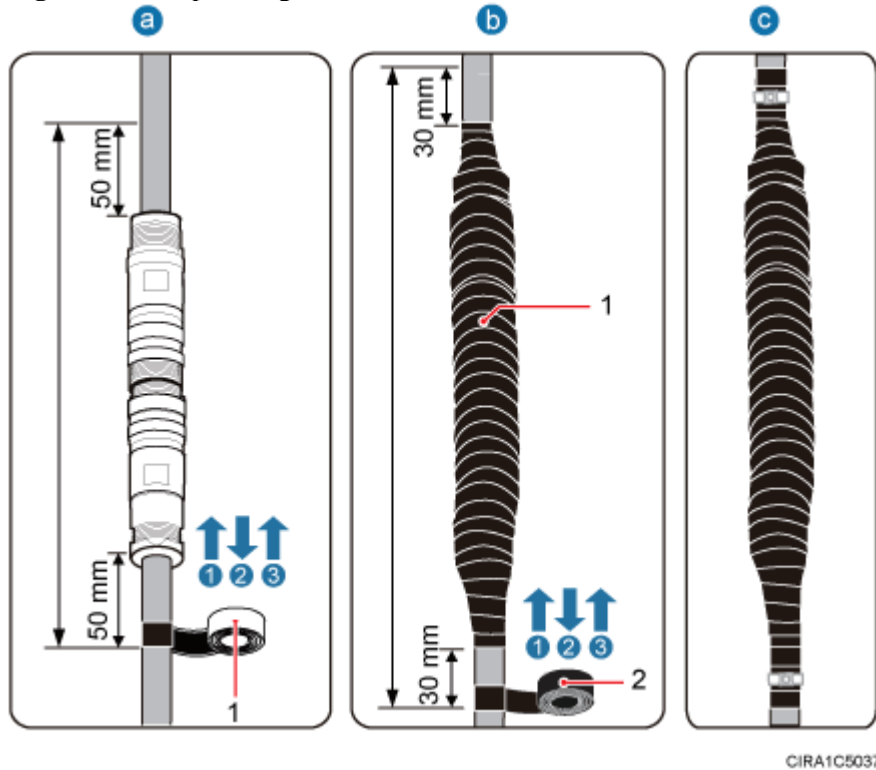

(1) Waterproof tape

(2) PVC insulation tape

6. Route the cables according to the instructions in [Cabling Requirements](#).
7. Label the installed cables according to the instructions in [Attaching an L-Shaped Label](#).

Parent Topic: [Installing RRU Cables](#)

Huawei Proprietary and Confidential Copyright © Huawei Technologies Co., Ltd.

Huawei Proprietary and Confidential

Copyright © Huawei Technologies Co., Ltd.

[< Previous topic](#) [Next topic >](#)

7.2.2.8.8 Opening the Cover Plate of an RRU Cabling Cavity

This section describes the procedure for opening the cover plate of an [RRU](#) cabling cavity.

Procedure

1. Wear ESD gloves.

NOTICE:

Take proper ESD protection measures, for example, wear ESD gloves, to prevent electrostatic damage to the boards, modules, or electronic components.

2. Use an M4 Phillips screwdriver to rotate the locking screw on the cover plate of the cabling cavity 90 degrees counterclockwise to unlock the cover plate. Then, pull the handle outwards to open the RRU cabling cavity, as shown in [Figure 1](#).

⚠ NOTICE:

Do not use the electric screwdriver to rotate the locking screw. Otherwise, the cross recess may be scratched.

Figure 1 Opening the cover plate of the RRU cabling cavity

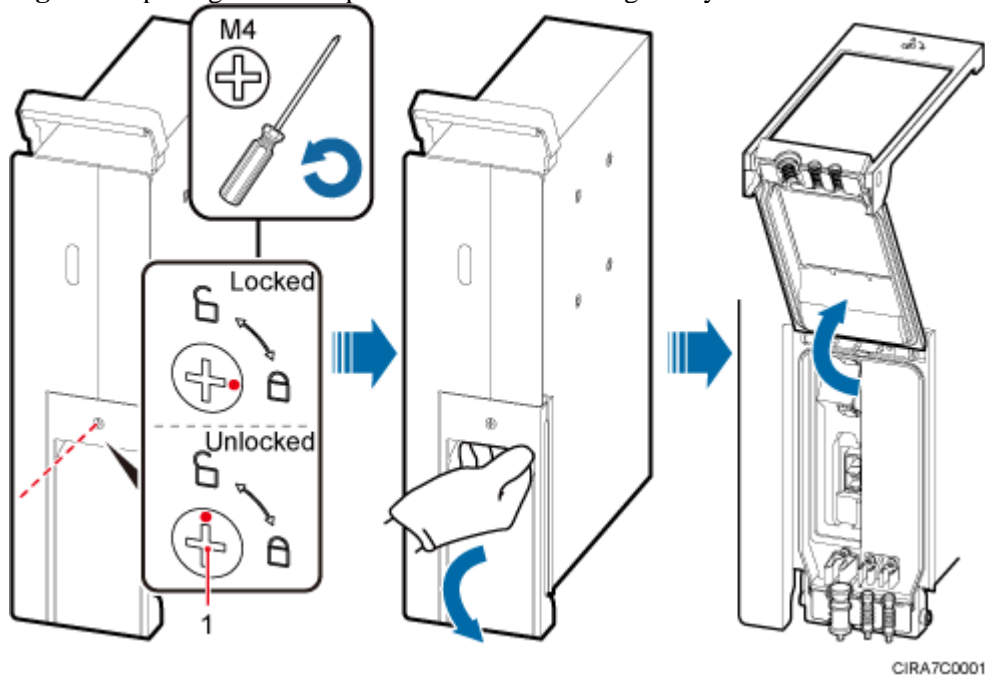

(1) Locking screw

[Figure 2](#) shows the internal structure of the cabling cavity.

Figure 2 RRU cabling cavity

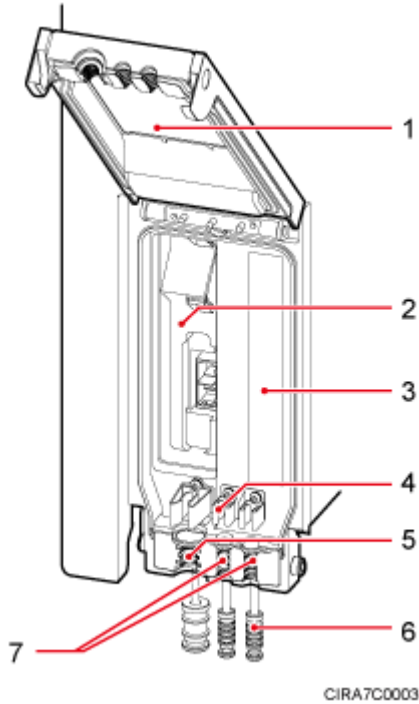

- | | | |
|---------------------------------------|------------------------|---|
| (1) Cover plate of the cabling cavity | (2) Cabling cavity | (3) Label for preparing the power cable |
| (4) Cable clip | (5) Power cable trough | (6) Waterproof block |
| (7) Optical cable trough | - | - |

3. Remove the waterproof block.

 **NOTE:**

Remove only the waterproof blocks for the cables to be installed.

Parent Topic: [Installing RRU Cables](#)

Huawei Proprietary and Confidential Copyright © Huawei Technologies Co., Ltd.

Huawei Proprietary and Confidential

Copyright © Huawei Technologies Co., Ltd.

[< Previous topic](#) [Next topic >](#)

7.2.2.8.9 Installing a CPRI Optical Fiber

This section describes the procedure for installing a [CPRI](#) optical fiber.

Prerequisites

Before the installation, single-mode optical modules can be distinguished from multimode optical modules in either of the following ways:

- SM and MM labels on an optical module: SM indicates a single-mode optical module, and MM indicates a multimode optical module.
- Color of the puller on an optical module: Blue indicates a single-mode optical module, and black or gray indicates a multimode optical module.

⚠NOTICE:

The optical modules to be installed must match CPRI rates.

Context

A CPRI optical fiber transmits CPRI signals between a **BBU** and an **RRU**.

⚠NOTICE:

- The performance of an optical module may deteriorate if it is exposed to the air for a long time. Therefore, after installing the optical module and before connecting the optical fiber, keep the dustproof cap in the port of the optical module.
 - The CPRI optical cables must be correctly connected in one time during the installation. Otherwise, the RRU may become faulty, causing cells to fail to provide services.
-

Procedure

1. Lower the pullers of two optical modules, insert one optical module into the CPRI0 port on the RRU and the other optical module into the CPRI port on the BBU, and raise the pullers, as shown in [Figure 1](#).

Figure 1 Installing an optical module

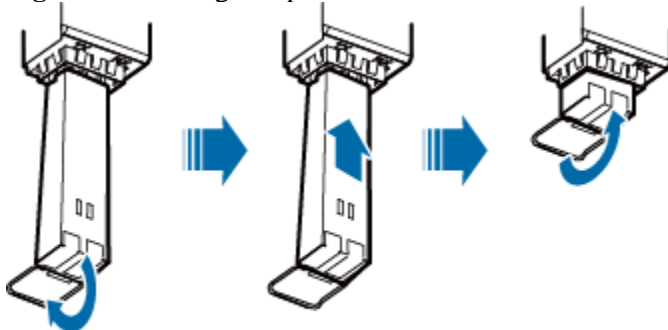

ICR06C4002

2. Install CPRI optical fibers.
-

⚠NOTICE:

- After removing dustproof caps from the optical module and optical fiber connector, insert the optical fiber into the optical module immediately (within one minute) to avoid pollution of the optical module or optical fiber connector, which may cause an optical module alarm.
- Ensure that CPRI optical fibers are correctly connected before the RRU is powered on. Otherwise, the RRU may become faulty, causing cells to fail to provide services.

- To avoid any damage to optical fibers, the fibers connected to the RRU must be installed according to the installation process. For details about the installation process, see [Installing RRU Cables](#).
-

- When installing CPRI optical fibers for dual-fiber bidirectional optical modules, remove the dustproof caps from the ports on the optical module and those from the optical fiber connector, and connect the end labeled 1A and 1B on the optical fiber to the optical modules on the RRU side, as shown in [Figure 2](#). Connect the DLC ends labeled 2A and 2B to the CPRI port on the main control board (such as the [GTMU](#)) or baseband processing board (such as the [WBBP](#)) in the BBU.

Figure 2 Installing CPRI optical fibers for dual-fiber bidirectional optical modules

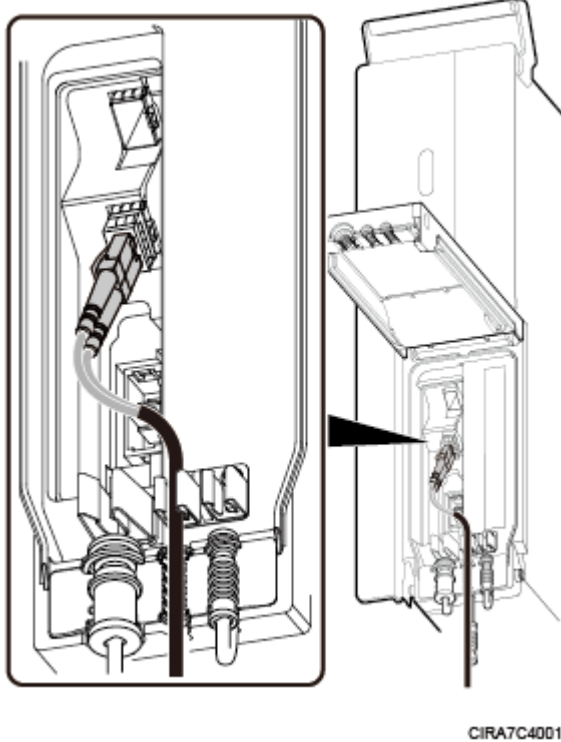

- When installing CPRI optical fibers for single-fiber bidirectional optical modules, remove the dustproof caps from the ports on the optical module and from the LC end labeled 1A on the optical cable, divide the DLC end into two LC ends, and connect the end labeled 1A to the optical module on the RRU side, as shown in [Figure 3](#). Connect the other LC end labeled 2A to the CPRI port on the main control board (such as the [GTMU](#)) or baseband processing board (such as the [WBBP](#)) in the BBU.

Figure 3 Installing CPRI optical fibers for single-fiber bidirectional optical modules

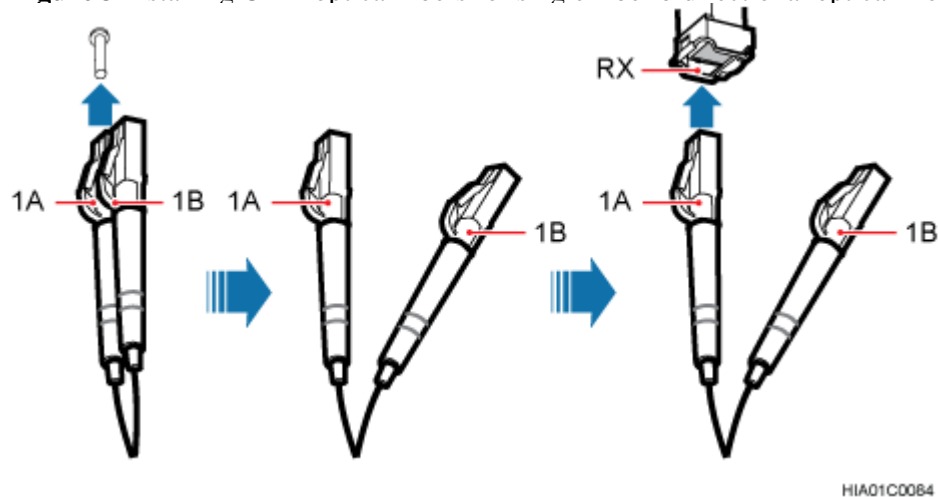

3. Route the cables according to the instructions in [Cabling Requirements](#).
4. Label the installed fibers according to the instructions in [Attaching an L-Shaped Label](#).

Parent Topic: [Installing RRU Cables](#)

Huawei Proprietary and Confidential Copyright © Huawei Technologies Co., Ltd.
Huawei Proprietary and Confidential
Copyright © Huawei Technologies Co., Ltd.
[< Previous topic](#) [Next topic >](#)

7.2.2.8.10 Installing an RRU power cable

This section describes the procedure for installing an [RRU](#) power cable.

Prerequisites

- A female fast connector (pressfit type) is added to the RRU power cable on the RRU side. For details, see [Adding a Female Fast Connector\(Pressfit Type\) to the RRU Power Cable on the RRU Side](#).
- A connector is added to the RRU power cable on the power device side. For details, see *DBS3900 Installation Guide* or *DBS5900 Installation Guide*.

Context

If a power device provided by the customer is used, the recommended specification of the circuit breaker on this power device is 20 A to 30 A.

[Table 1](#) describes RRU power cables.

Table 1 RRU power cables

Cable	On the RRU Side	On the Power Device Side	Power Device	Color
RRU power cable	Female fast connector (pressfit type)	Female fast connector (pressfit type)	EPU	A cable with a black jacket and two wires inside <ul style="list-style-type: none">• North American standards: The RTN(+) wire is black and the NEG(-) wire is blue.• European standards: The RTN(+) wire is brown and the NEG(-) wire is blue.• China: The RTN(+) wire is red and the NEG(-) wire is blue.
		EPC5 connector	DCDU-12B	

**CAUTION:**

- Before installing RRU power cables, ensure that the upper-level circuit breaker is disconnected, and the power cable has no voltage.
- A drip loop is required for the position between the RRU port and the cable, preventing rain from damaging the RRU.
- When installing the RRU power cable, connect the power cable to the RRU connector first and then to the power equipment connector. Incorrect connection sequence or reverse connection of positive and negative poles may damage the RRU or cause personal injury.

Procedure

1. Connect the female fast connector (pressfit type) at one end of the RRU power cable to the power supply socket on the RRU, as shown in [Figure 1](#).

Figure 1 Installing an RRU power cable

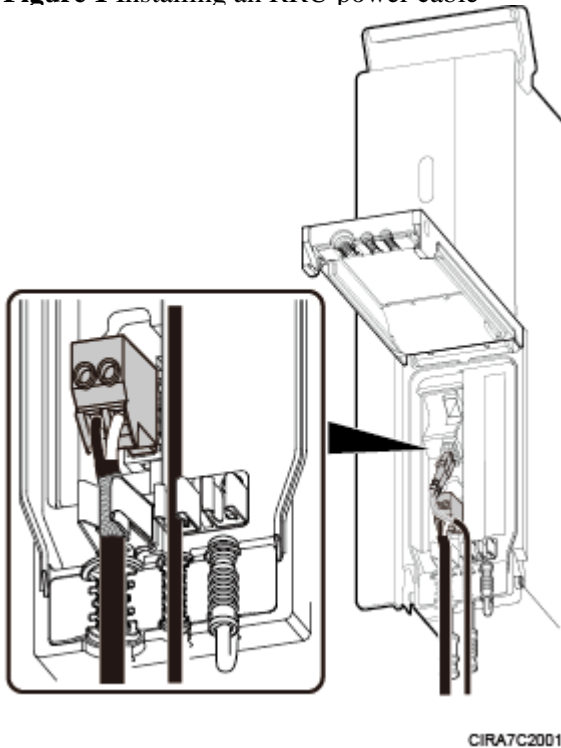

⚠ NOTICE:

Ensure that the exposed shield layer of the power cable is properly tightened using the clip.

2. Connect the connector at the other end of the RRU power cable to the corresponding position on the power device.
-

📖 NOTE:

- A DCDU-11B/DCDU-12B can supply power to a maximum of six RRUs. Ensure that the RRU power cable is connected to one of **LOAD0** to **LOAD5** ports on the DCDU-11B/DCDU-12B.
 - When the EPU supplies power, the maximum number of RRUs that can be connected to the EPU depends on the cabinet type. For details about RRU power cable connections, see *DBS3900 Installation Guide* or *DBS5900 Installation Guide*.
-

3. Route the cables according to the instructions in [Cabling Requirements](#).
4. Label the installed fibers according to the instructions in [Attaching a Cable-Tying Label](#).

Parent Topic: [Installing RRU Cables](#)

Huawei Proprietary and Confidential Copyright © Huawei Technologies Co., Ltd.

Huawei Proprietary and Confidential

Copyright © Huawei Technologies Co., Ltd.

[< Previous topic](#) [Next topic >](#)

7.2.2.8.11 Closing the Cover Plate of an RRU Cabling Cavity

This section describes the procedure for closing the cover plate of an RRU cabling cavity.

Procedure

1. Fasten the cables using clips, as shown in [Figure 1](#).

NOTICE:

Ensure that the exposed shield layer of the power cable is properly tightened using the clip.

Figure 1 Fastening cables using clips

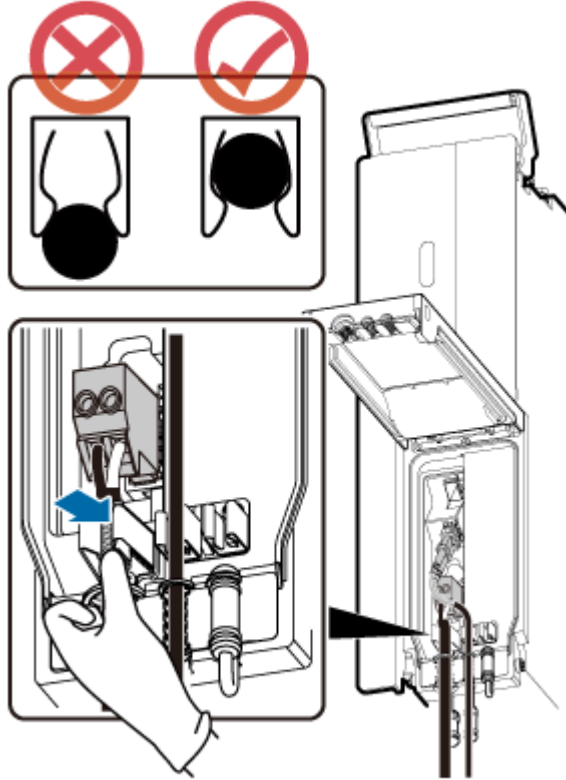

CIRA1C1010

2. Insert waterproof blocks into vacant cable troughs in the cabling cavity, as shown in [Figure 2](#).

NOTICE:

Ensure that cables and waterproof blocks are properly inserted into troughs.

Figure 2 Correct placement of waterproof blocks

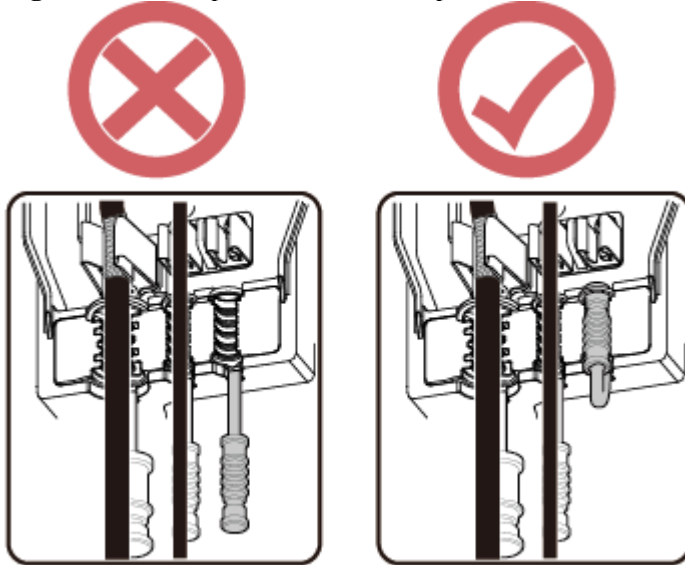

EIRA8C1003

3. Push the handle to close the cover plate of the cabling cavity. Then, use an M4 Phillips screwdriver to rotate the locking screw on the cover plate of the cabling cavity 90 degrees clockwise shown in the following figure to lock the cover plate of the cabling cavity, as shown in [Figure 3](#).

⚠ NOTICE:

- Do not use the electric screwdriver to rotate the locking screw. Otherwise, the cross recess may be scratched.
 - The RRU cabling cavity must be securely tightened to prevent water.
-

Figure 3 Closing the cover plate of an RRU cabling cavity

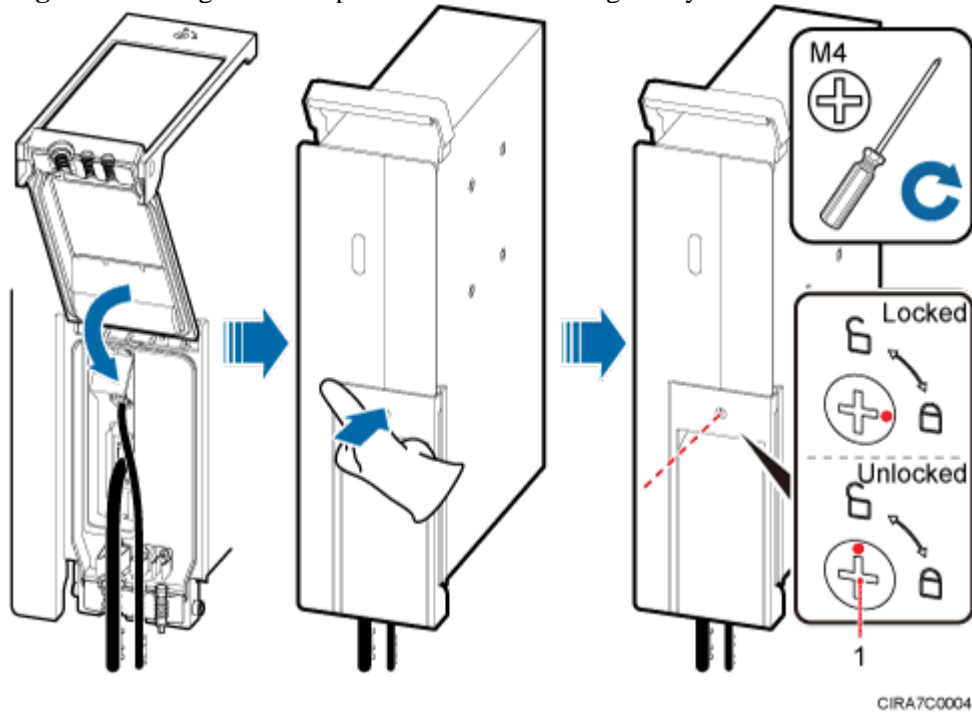

(1) Locking screw

4. Take off the ESD gloves, and pack up all the tools.

Parent Topic: [Installing RRU Cables](#)

Huawei Proprietary and Confidential Copyright © Huawei Technologies Co., Ltd.

Huawei Proprietary and Confidential

Copyright © Huawei Technologies Co., Ltd.

[< Previous topic](#)

7.2.2.9 Checking the RRU Hardware Installation

[Table 1](#) provides the checklist for the [RRU](#) hardware installation.

Table 1 Checklist for the RRU hardware installation	
SN	Item
1	The position for each device conforms to the engineering drawing and meets the space requirement. Sufficient space is reserved for equipment maintenance.
2	The RRU is securely installed.
3	The cover plate is securely installed on the RRU cabling cavity.

Table 1 Checklist for the RRU hardware installation

SN	Item
4	Waterproof blocks are securely installed in vacant cable troughs of the RRU cabling cavity, and the cover plate for the cabling cavity is securely installed. In addition, vacant RF ports are covered with dustproof caps and the caps are tightened.
5	There are no connectors or joints on each power cable or PGND cable.
6	The terminals at two ends of each power cable or PGND cable are securely soldered or crimped.
7	None of power cables and PGND cables can be short-circuited or reversely connected. In addition, these cables are not damaged or broken.
8	Power cables and PGND cables are separately bound from other cables.
9	The protection grounding of the RRU and the surge protection grounding of the building share one group of ground conductors.
10	The connectors of each signal cable are intact and securely linked, and these cables are not damaged or broken.
11	Labels are correct, legible, and complete at both ends of each cable, feeder, and jumper.
12	All ground cables are properly grounded.

Huawei Proprietary and Confidential Copyright © Huawei Technologies Co., Ltd.

Huawei Proprietary and Confidential

Copyright © Huawei Technologies Co., Ltd.

[< Previous topic](#) [Next topic >](#)

7.2.2.10 Powering On an RRU

After all the devices are installed, check the power-on status of an RRU.

NOTICE:

After you unpack an RRU, you must power on it within 24 hours. If you power off the RRU for maintenance, you must restore power to the RRU within 24 hours.

[Figure 1](#) shows the RRU power-on check process.

NOTE:

For details about how to power on an RRU and how to power off an RRU, see section "Powering-On the RRU" and section "Powering-Off the RRU" in *RRU Maintenance Guide*.

Figure 1 RRU power-on check process

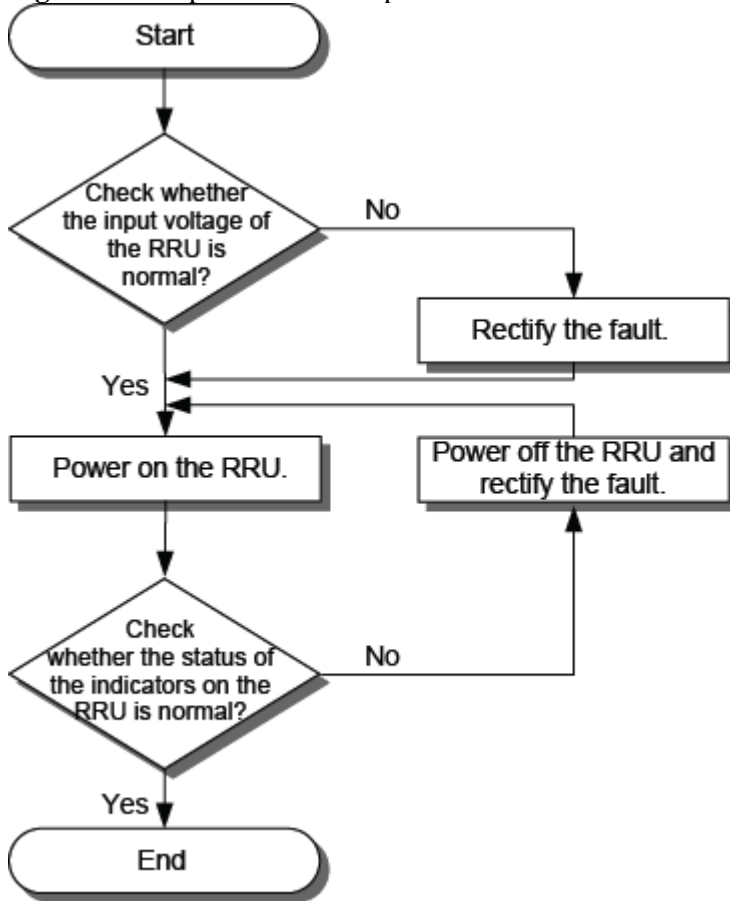

IPR06C0003

(a) The normal input voltage of an RRU is -48 V DC. The voltage of the external power supply should range from -36 V DC to -57 V DC.

(b) The RUN indicator on the RRU is on for 1s and off for 1s. The ALM indicator is steady off.

Huawei Proprietary and Confidential Copyright © Huawei Technologies Co., Ltd.

Huawei Proprietary and Confidential

Copyright © Huawei Technologies Co., Ltd.

[< Previous topic](#) [Next topic >](#)

7.2.2.11 Appendix

[Adding a Female Fast Connector\(Pressfit Type\) to the RRU Power Cable on the RRU Side](#)

This section describes the procedure for adding a female fast connector(Pressfit Type) to the RRU power cable on the RRU side.

Huawei Proprietary and Confidential Copyright © Huawei Technologies Co., Ltd.

Huawei Proprietary and Confidential

Copyright © Huawei Technologies Co., Ltd.

[< Previous topic](#)

7.2.2.11.1 Adding a Female Fast Connector(Pressfit Type) to the RRU Power Cable on the RRU Side

This section describes the procedure for adding a female fast connector(Pressfit Type) to the RRU power cable on the RRU side.

Context

Figure 1 shows the cable diagram on labels.

Figure 1 Cable diagram on labels

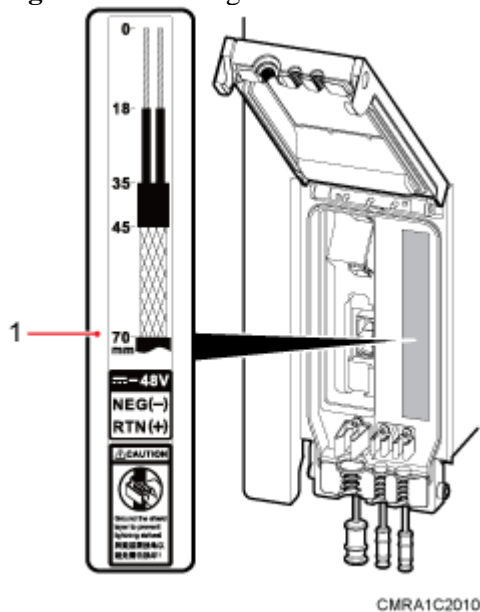

(1) Cable diagram on labels

⚠NOTICE:

Prepare a female fast connector (Pressfit Type) to the RRU power cable on the RRU side by strictly following the following operations. Otherwise, damage to the RRU or personal injury may occur.

Procedure

1. Determine the length of the power cable for different operations based on the labels, as shown in Figure 2.

Figure 2 Determining the length of the power cable

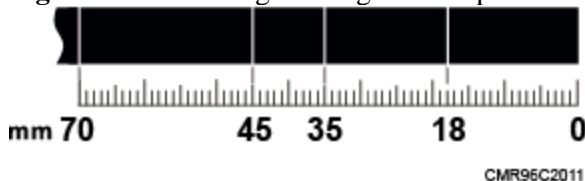

- Strip the specified length of the sheath off the power cable, as shown in [Figure 3](#).

Figure 3 Stripping the specified length of sheath

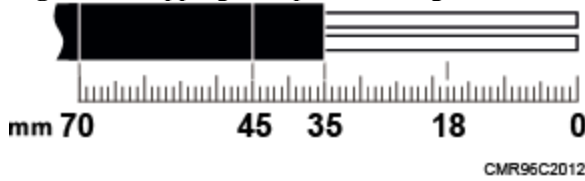

- Strip a specified length of sheath off each core wire. The length must be consistent with the length of the notch in the female fast connector (Pressfit Type), as shown in [Figure 4](#).

Figure 4 Stripping the sheath off each core wire

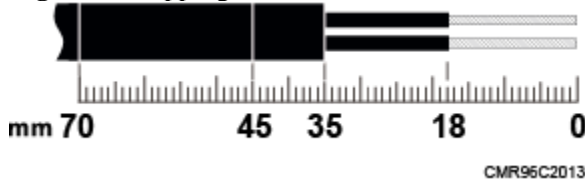
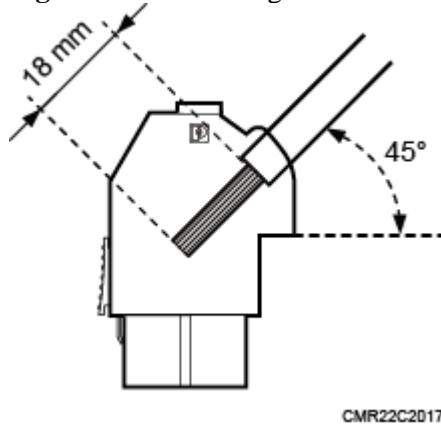
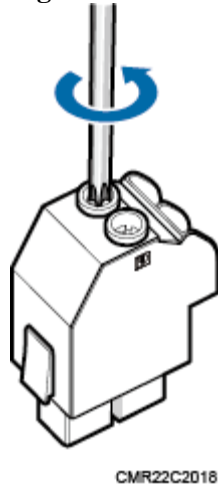

Figure 5 Matched length



- Add a female fast connector (pressfit type) to two core wires.
 - Loosen the screws using a Phillips screwdriver, as shown in [Figure 6](#).

Figure 6 Loosening screws



- b. Connect the blue core wire labeled NEG(-) to the - port and the black/red/brown core wire labeled RTN(+) to the + port on the female fast connector (pressfit type), and then tighten the screws using a Phillips screwdriver to 1.4 N·m (12.39 lbf·in.), as shown in [Figure 7](#).



DANGER:

Do not reversely connect the positive and negative poles. Reverse connection of positive and negative poles may result in equipment malfunctions or personal injury. Therefore, check the power cable connection before powering on the RRU.



NOTE:

Colors of wires in RRU power cables vary depending on regions. In figures of this section, the blue one is an NEG(-) cable, and the black one is an RTN(+) one.

Figure 7 Adding a female fast connector (pressfit type) to two core wires

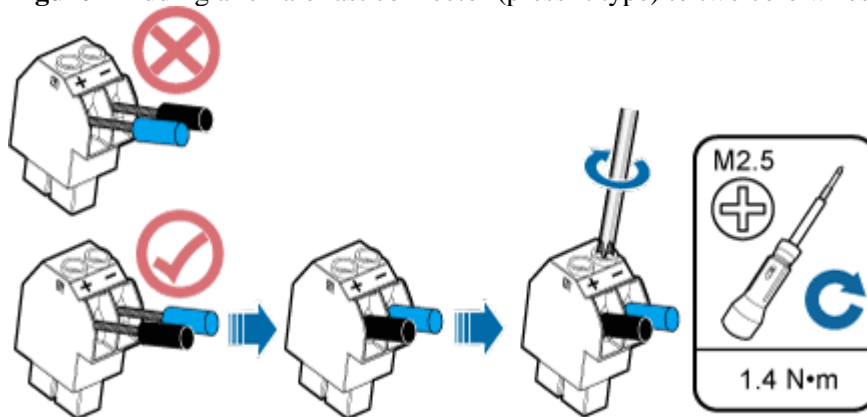

CMR22C2019

- c. After the core wires are installed, ensure that each core wire is securely installed after being dragged with a torque of 30 N·m and all copper wires are inserted in the connector terminal socket.
5. Strip the specified length of the sheath off the power cable to expose the intact shield layer, as shown in [Figure 8](#).

Figure 8 Stripping the sheath off the power cable

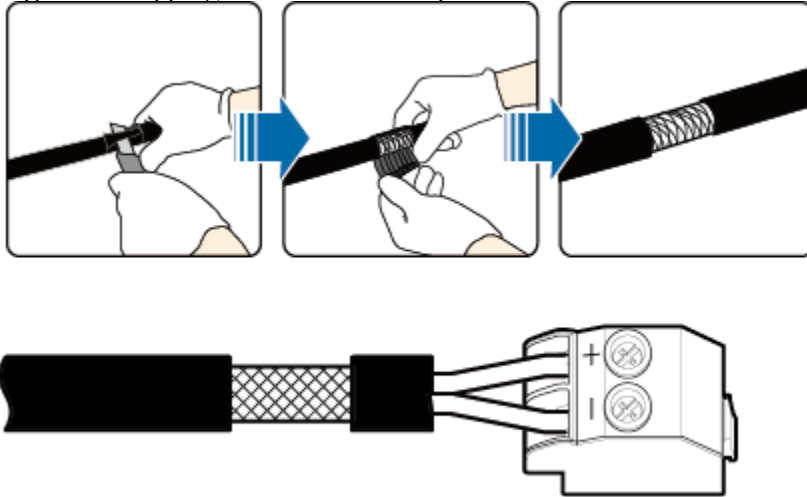

CMR22C2014

⚠ NOTICE:

Each core wire is exposed outside the female fast connector (pressfit type) for 1.5 mm (0.059 in.), as shown in [Figure 9](#).

Figure 9 Inserting core wires into the female fast connector (pressfit type)

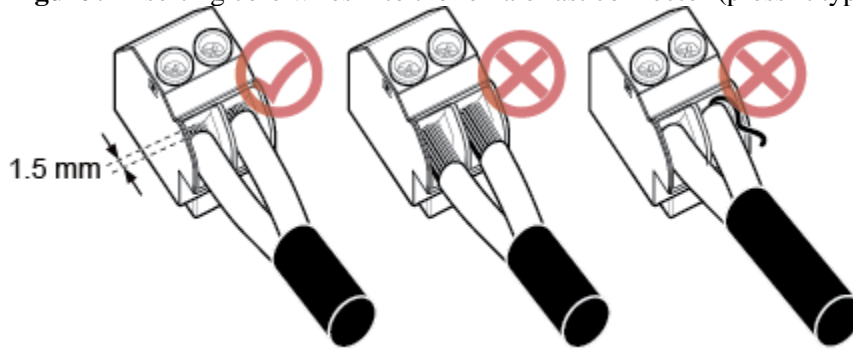

EID00C2000

Exception Handling

If the power terminal or cable is damaged or abnormal, remove the power cable.

1. Press the spring clip of the power terminal using a screwdriver and remove the power cable.

Figure 10 Pressing the spring clip of the power terminal

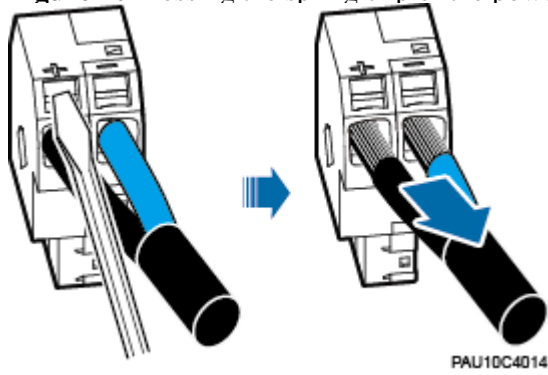

Parent Topic: [Appendix](#)

Huawei Proprietary and Confidential Copyright © Huawei Technologies Co., Ltd.
Huawei Proprietary and Confidential
Copyright © Huawei Technologies Co., Ltd.