



RRU3908 V2

V100

Hardware Description

Issue 02

Date 2010-10-25

Copyright © Huawei Technologies Co., Ltd. 2010. All rights reserved.

No part of this document may be reproduced or transmitted in any form or by any means without prior written consent of Huawei Technologies Co., Ltd.

Trademarks and Permissions



HUAWEI and other Huawei trademarks are trademarks of Huawei Technologies Co., Ltd.

All other trademarks and trade names mentioned in this document are the property of their respective holders.

Notice

The purchased products, services and features are stipulated by the contract made between Huawei and the customer. All or part of the products, services and features described in this document may not be within the purchase scope or the usage scope. Unless otherwise specified in the contract, all statements, information, and recommendations in this document are provided "AS IS" without warranties, guarantees or representations of any kind, either express or implied.

The information in this document is subject to change without notice. Every effort has been made in the preparation of this document to ensure accuracy of the contents, but all statements, information, and recommendations in this document do not constitute the warranty of any kind, express or implied.

Huawei Technologies Co., Ltd.

Address: Huawei Industrial Base
Bantian, Longgang
Shenzhen 518129
People's Republic of China

Website: <http://www.huawei.com>

Email: support@huawei.com

About This Document

Purpose

This document describes the exterior, panels, LEDs, and cables of the RRU3908 V2.

Product Version

The following table lists the product versions related to this document.

Product Name	Product Version
RRU3908 V2 (hereinafter referred to as RRU3908)	SRAN V100R002
	SRAN V100R003
	eRAN V100R002C00

Intended Audience

This document is intended for:

- BTS installation engineers
- Site maintenance engineers
- System engineer

Organization

1 Changes in the RRU3908 V2 Hardware Description

This chapter describes the changes in the *RRU3908 V2 Hardware Description*.

2 Introduction to the RRU3908

The RRU is the outdoor remote radio unit.

3 RRU Cables

The RRU cables consist of the PGND cable, power cable, CPRI optical cable, RRU RF cable, alarm cable, AISG multi-wire cable, and AISG extension cable.





4 Auxiliary Devices of the RRU

The auxiliary devices of the RRU consist of the AC power surge protection box, Indoor Floor installation Support (IFS06), and Outdoor Cable Conversion Box (OCB).

Conventions

Symbol Conventions

The symbols that may be found in this document are defined as follows.

Symbol	Description
 DANGER	Indicates a hazard with a high level of risk, which if not avoided, will result in death or serious injury.
 WARNING	Indicates a hazard with a medium or low level of risk, which if not avoided, could result in minor or moderate injury.
 CAUTION	Indicates a potentially hazardous situation, which if not avoided, could result in equipment damage, data loss, performance degradation, or unexpected results.
 TIP	Indicates a tip that may help you solve a problem or save time.
 NOTE	Provides additional information to emphasize or supplement important points of the main text.

General Conventions

The general conventions that may be found in this document are defined as follows.

Convention	Description
Times New Roman	Normal paragraphs are in Times New Roman.
Boldface	Names of files, directories, folders, and users are in boldface . For example, log in as user root .
<i>Italic</i>	Book titles are in <i>italics</i> .
Courier New	Examples of information displayed on the screen are in Courier New.

Command Conventions

The command conventions that may be found in this document are defined as follows.

Convention	Description
Boldface	The keywords of a command line are in boldface .
<i>Italic</i>	Command arguments are in <i>italics</i> .
[]	Items (keywords or arguments) in brackets [] are optional.
{ x y ... }	Optional items are grouped in braces and separated by vertical bars. One item is selected.
[x y ...]	Optional items are grouped in brackets and separated by vertical bars. One item is selected or no item is selected.
{ x y ... }*	Optional items are grouped in braces and separated by vertical bars. A minimum of one item or a maximum of all items can be selected.
[x y ...]*	Optional items are grouped in brackets and separated by vertical bars. Several items or no item can be selected.

GUI Conventions

The GUI conventions that may be found in this document are defined as follows.

Convention	Description
Boldface	Buttons, menus, parameters, tabs, window, and dialog titles are in boldface . For example, click OK .
>	Multi-level menus are in boldface and separated by the ">" signs. For example, choose File > Create > Folder .

Keyboard Operations

The keyboard operations that may be found in this document are defined as follows.

Format	Description
Key	Press the key. For example, press Enter and press Tab .
Key 1+Key 2	Press the keys concurrently. For example, pressing Ctrl+Alt+A means the three keys should be pressed concurrently.
Key 1, Key 2	Press the keys in turn. For example, pressing Alt, A means the two keys should be pressed in turn.

Mouse Operations

The mouse operations that may be found in this document are defined as follows.

Action	Description
Click	Select and release the primary mouse button without moving the pointer.
Double-click	Press the primary mouse button twice continuously and quickly without moving the pointer.
Drag	Press and hold the primary mouse button and move the pointer to a certain position.

Contents

About This Document.....	iii
1 Changes in the RRU3908 V2 Hardware Description.....	1-1
2 Introduction to the RRU3908.....	2-1
2.1 Physical Exterior.....	2-2
2.2 Panels of the RRU.....	2-3
2.3 LEDs on the RRU.....	2-6
3 RRU Cables.....	3-1
3.1 RRU3908 Cable List.....	3-3
3.2 RRU PGND Cable.....	3-4
3.3 Power Cable for the DC RRU.....	3-5
3.4 AC Power Cable for the AC RRU.....	3-6
3.5 Monitoring Signal Cable for the AC RRU.....	3-8
3.6 CPRI Optical Cable.....	3-9
3.7 Alarm Cable for the DC RRU.....	3-11
3.8 RF Jumper for the RRU.....	3-13
3.9 Interconnect Jumper for the RRU.....	3-13
3.10 AISG Multi-Wire Cable for the RRU.....	3-14
3.11 AISG Extension Cable for the RRU.....	3-15
4 Auxiliary Devices of the RRU.....	4-1
4.1 AC Power Surge Protection Box.....	4-2
4.2 IFS06.....	4-3
4.3 OCB.....	4-5

Figures

Figure 2-1 DC RRU.....	2-2
Figure 2-2 AC RRU.....	2-3
Figure 2-3 Panels of the DC RRU.....	2-4
Figure 2-4 Panels of the AC RRU.....	2-5
Figure 3-1 PGND cable.....	3-5
Figure 3-2 2-hole OT terminal.....	3-5
Figure 3-3 Power cable for the DC RRU.....	3-5
Figure 3-4 Power cable between the AC RRU and the external power equipment.....	3-6
Figure 3-5 Power cable between the AC RRU and the AC surge protection box.....	3-7
Figure 3-6 Power cable between the AC surge protection box and the external power equipment.....	3-7
Figure 3-7 Monitoring signal cable of the AC RRU.....	3-9
Figure 3-8 Multi-mode optical cable	3-10
Figure 3-9 Single-mode optical cable.....	3-10
Figure 3-10 Alarm cable.....	3-12
Figure 3-11 RF jumper.....	3-13
Figure 3-12 Interconnect jumper.....	3-13
Figure 3-13 AISG multi-wire cable.....	3-14
Figure 3-14 AISG extension cable.....	3-15
Figure 4-1 AC power surge protection box.....	4-2
Figure 4-2 IFS06.....	4-4
Figure 4-3 Structure of the IFS06.....	4-5
Figure 4-4 The application scenario of the OCB.....	4-6

Tables

Table 2-1 Ports, buttons, and LEDs on the panels of the RRU module.....	2-5
Table 2-2 LEDs on the RRU.....	2-6
Table 3-1 RRU3908 cables.....	3-3
Table 3-2 Pin assignment for the wires of the power cable (North American standard).....	3-6
Table 3-3 Pin assignment for the wires of the power cable (European standard).....	3-6
Table 3-4 Pin assignment for the wires of the AC power cable between the AC RRU and the external power equipment.....	3-7
Table 3-5 Pin assignment for the wires of the AC power cable between the AC RRU and the AC surge protection box.....	3-8
Table 3-6 Pin Assignment for the wires of the power cable between the AC surge protection box and the power supply device.....	3-8
Table 3-7 Pin assignment for the wires of the monitoring power cable (North American standard).....	3-9
Table 3-8 Pin assignment for the wires of the monitoring power cable (European standard).....	3-9
Table 3-9 Labels and recommended connections for the branch cables of the multi-mode optical cable between the BBU and RRU.....	3-11
Table 3-10 Labels and recommended connections for the branch cables of the multi-mode optical cable between RRUs.....	3-11
Table 3-11 Labels and recommended connections for the branch cables of the single-mode optical cable and recommended connections.....	3-11
Table 3-12 Pin assignment for the wires of the RRU alarm cable.....	3-12
Table 3-13 Pin assignment for the wires of the AISG multi-wire cable.....	3-14
Table 3-14 Pin assignment for the wires of the AISG extension cable.....	3-16
Table 4-1 Specifications of the AC power surge protection box.....	4-2
Table 4-2 Ports on the AC power surge protection box.....	4-3
Table 4-3 Specifications of the IFS06.....	4-5

1 Changes in the RRU3908 V2 Hardware Description

This chapter describes the changes in the *RRU3908 V2 Hardware Description*.

02 (2010-10-25)

This is the commercial release.

Compared with issue 01 (2010-05-20), this issue does not add any information.

Compared with issue 01 (2010-05-20), this issue incorporates the following changes:

Topic	Change Description
3.7 Alarm Cable for the DC RRU	The description on the pins of the RRU alarm cable is optimized.

Compared with issue 01 (2010-05-20), this issue does not remove any information.

01 (2010-05-20)

This is the draft release.

2 Introduction to the RRU3908

About This Chapter

The RRU is the outdoor remote radio unit.

The RRU3908 performs the following functions:

- Receives downlink baseband data from the BBU and transmits uplink baseband data to the BBU for communication between the RRU and the BBU.
- Receives the RF signals from the antenna system, down-converts the RX signals to Intermediate Frequency (IF) signals, perform amplification, and analog-to-digital (A/D) conversion. The TX channel performs shape filtering of the downlink signals, digital-to-analog(D/A) conversion, and up-conversion of RF signals to transmit band.
- Multiplexes RX and TX signals to enable these signals to share the same antenna path, and filters RX and TX signals.

2.1 Physical Exterior

The RRU has a modular structure. The external ports of the RRU are located at the bottom and in the cabling cavity of the RRU.

2.2 Panels of the RRU

The RRU module has a bottom panel, a cabling cavity panel, and an area attached with LEDs.

2.3 LEDs on the RRU

The six LEDs on the RRU are used to display the running status of the RRU.

2.1 Physical Exterior

The RRU has a modular structure. The external ports of the RRU are located at the bottom and in the cabling cavity of the RRU.

Figure 2-1 shows the DC RRU.

Figure 2-1 DC RRU

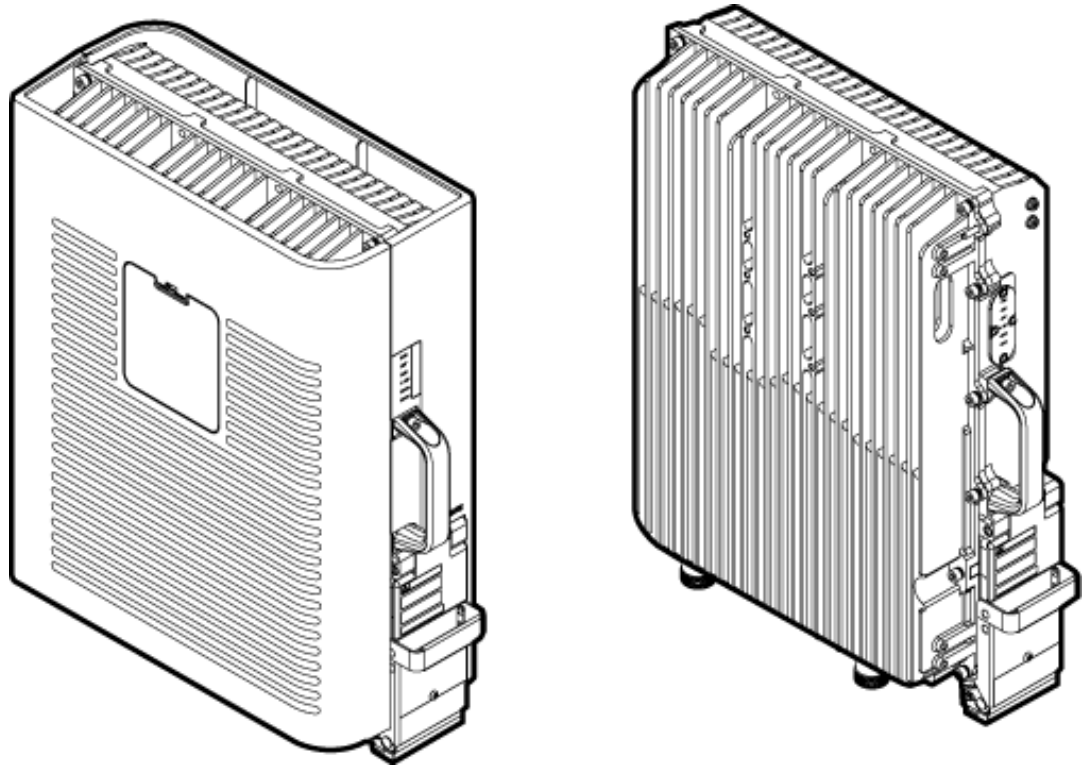
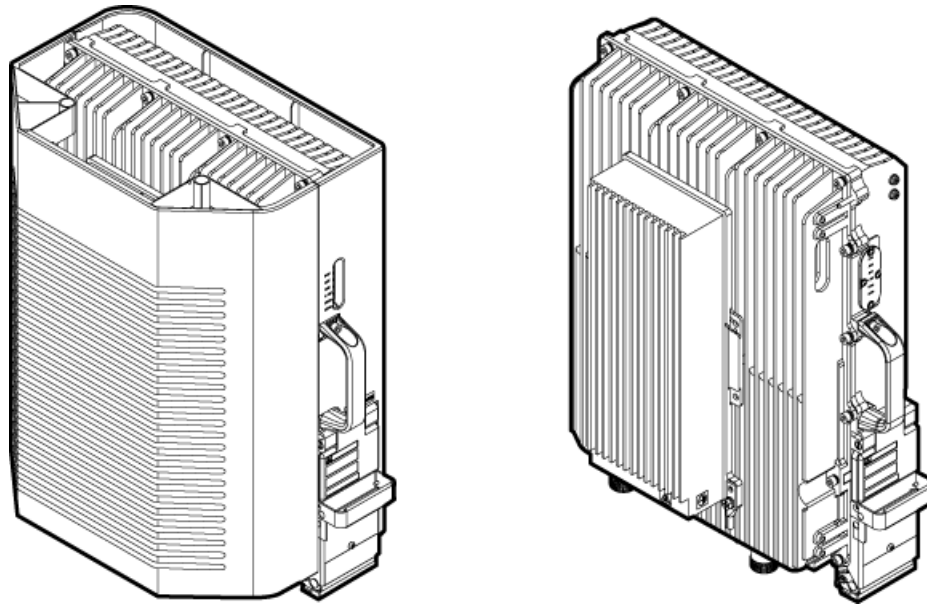

Figure 2-2 shows the AC RRU.

Figure 2-2 AC RRU



2.2 Panels of the RRU

The RRU module has a bottom panel, a cabling cavity panel, and an area attached with LEDs.

[Figure 2-3](#) shows the panels of the DC RRU.

Figure 2-3 Panels of the DC RRU

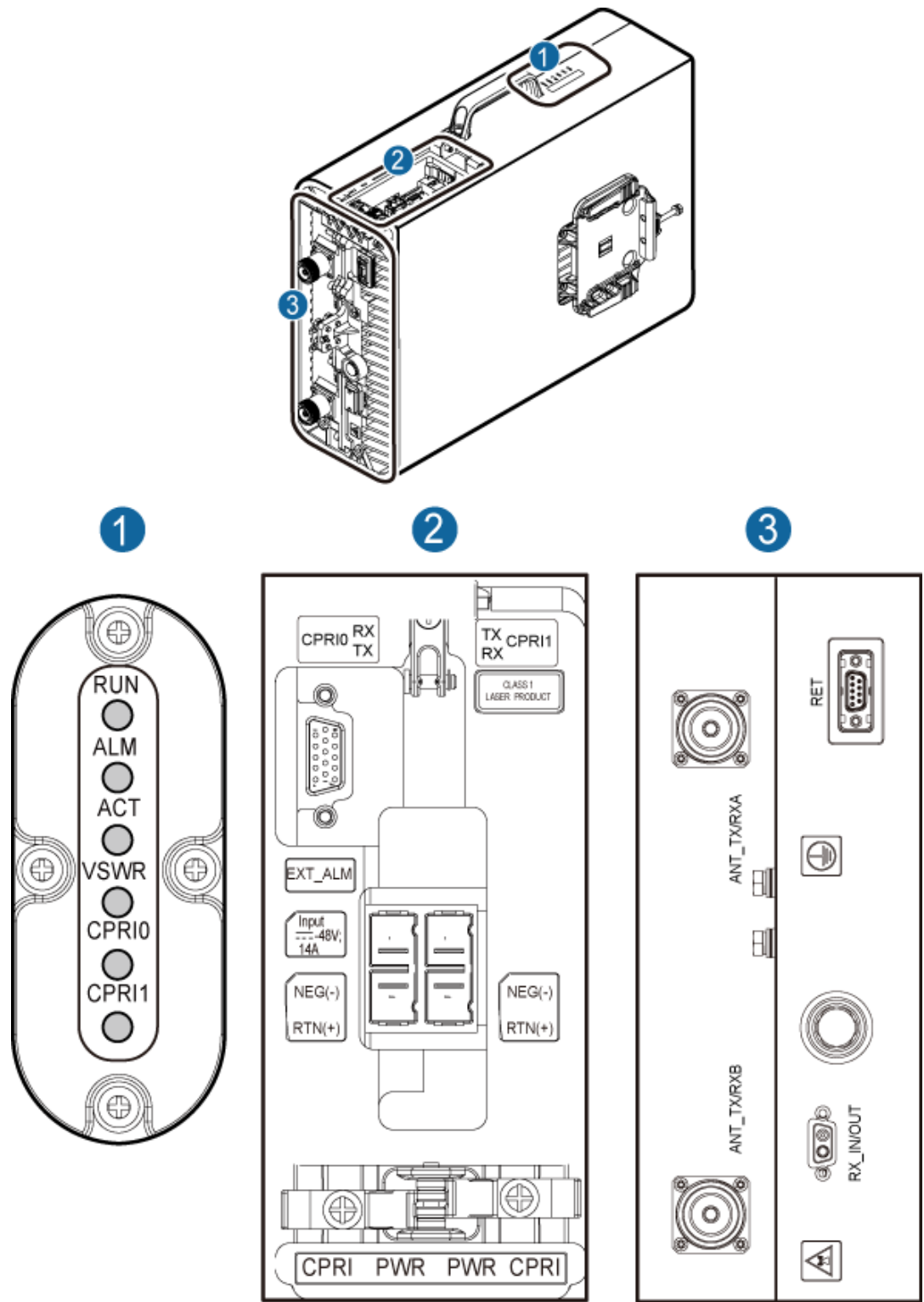

Figure 2-4 shows the panels of the AC RRU.

Figure 2-4 Panels of the AC RRU

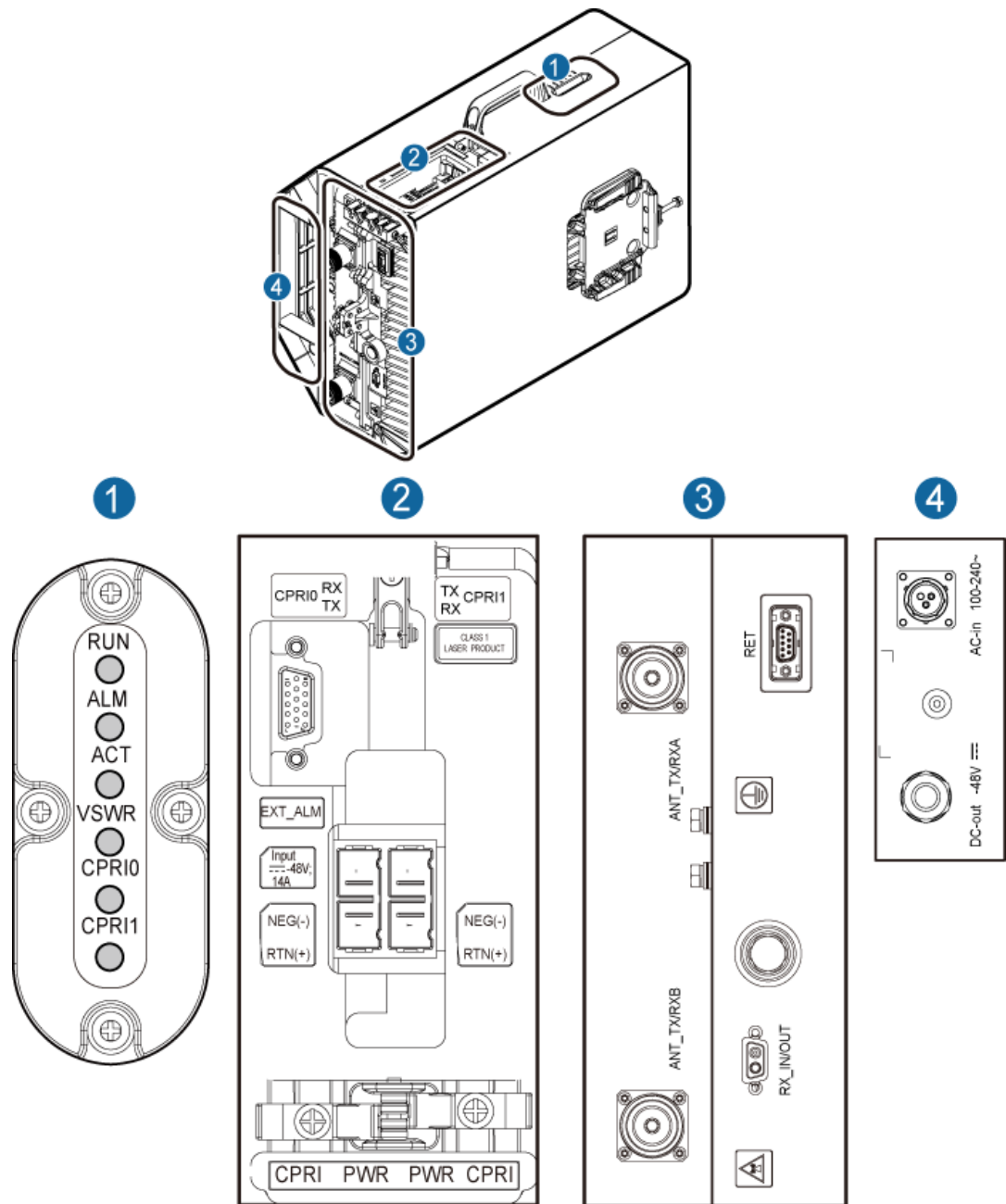

Table 2-1 describes the LEDs, cabling cavity panel, and bottom panel of the RRU.

Table 2-1 Ports, buttons, and LEDs on the panels of the RRU module

Item	Label	Description
(1) LEDs	RUN	Refer to 2.3 LEDs on the RRU .
	ALM	

Item	Label	Description
	ACT	
	VSWR	
	CPRI0	
	CPRI1	
(2) Cabling cavity panel	RTN(+) 0	Power supply port
	NEG(-) 0	
	RTN(+) 1	Cascaded power supply port
	NEG(-) 1	
	RX TX CPRI0	Optical/electrical port 0
	TX RX CPRI1	Optical/electrical port 1
	EXT_ALM	Alarm port
(3) Bottom panel of the RRU	RX_IN/OUT	RF interconnection port
	RET	RET antenna port
	ANT_TX/RXA	RF TX/RX port A
	ANT_TX/RXB	RF TX/RX port B
(4) Bottom panel of AC conversion module	AC-in	AC power supply socket
	DC-out	DC power supply socket

2.3 LEDs on the RRU

The six LEDs on the RRU are used to display the running status of the RRU.

For details on the positions of the LEDs on the panel of the RRU, see [2.2 Panels of the RRU](#).

[Table 2-2](#) describes the LEDs on the RRU.

Table 2-2 LEDs on the RRU

LED	Color	Status	Description
RUN	Green	On	There is power supply, but the board is faulty.
		Off	There is no power supply, or the board is faulty.
		Blinking (on for 1s and off for 1s)	The board is running properly.

LED	Color	Status	Description
		Blinking (on for 0.125s and off for 0.125s)	Data is being loaded to the board, or the board is not started.
ALM	Red	On	Alarms are generated, and the module needs to be replaced.
		Blinking (on for 1s and off for 1s)	Alarms are reported. The alarms may be caused by the faults of other related boards or ports. Therefore, whether the module needs to be replaced cannot be decided.
		Off	No alarm is generated.
ACT	Green	On	The board works properly with the TX channel enabled.
		Blinking (on for 1s and off for 1s)	The board works properly with the TX channel disabled.
VSWR	Red	Off	No VSWR alarm is generated.
		On	A VSWR alarm is generated on the ANT_TX/RXB port.
		Blinking (on for 1s and off for 1s)	A VSWR alarm is generated on the ANT_TX/RXA port.
		Blinking (on for 0.125s and off for 0.125s)	A VSWR-related alarm is generated on both the ANT_TX/RXA port and the ANT_TX/RXB port.
CPRI0	Red/ Green	Steady green	The CPRI link is functional.
		Steady red	The optical module fails to receive signals.
		Blinking red (on for 1s and off for 1s)	The CPRI link is out of lock.
		Off	The SFP module is not in position or the optical module is powered off.
CPRI1	Red/ Green	Steady green	The CPRI link is functional.
		Steady red	The optical module fails to receive signals.
		Blinking red (on for 1s and off for 1s)	The CPRI link is out of lock.
		Off	The SFP module is not in position or the optical module is powered off.

3 RRU Cables

About This Chapter

The RRU cables consist of the PGND cable, power cable, CPRI optical cable, RRU RF cable, alarm cable, AISG multi-wire cable, and AISG extension cable.

[3.1 RRU3908 Cable List](#)

The RRU3908 cables are the PGND cable, power cable, CPRI optical cable, RF jumper, interconnection jumper, alarm cable, AISG multi-wire cable, and AISG extension cable.

[3.2 RRU PGND Cable](#)

The PGND cable ensures the grounding of the RRU.

[3.3 Power Cable for the DC RRU](#)

The RRU power cable is the -48 V DC shielded power cable, which is used to feed the -48 V DC power into the RRU.

[3.4 AC Power Cable for the AC RRU](#)

The AC power cable feeds AC power from external equipment to the AC RRU.

[3.5 Monitoring Signal Cable for the AC RRU](#)

The monitoring signal cable for the AC RRU feeds power to the AC RRU and monitors the running status of the RRU.

[3.6 CPRI Optical Cable](#)

The CPRI optical cable transmits CPRI signals between the BBU and the RRU or between RRUs.

[3.7 Alarm Cable for the DC RRU](#)

The alarm cable for the RRU is a shielded straight-through cable. The cable transmits alarm signals from the external equipment to the DC RRU and monitors the external equipment.

[3.8 RF Jumper for the RRU](#)

The 1/2-inch RF jumper is used for the RRU. It transmits and receives RF signals between the RRU and antenna.

[3.9 Interconnect Jumper for the RRU](#)

The interconnect jumper for the RRU connects the **RX_IN/OUT** ports of two RRUs, and transmits the RF signals between the RRUs in the same cell.

[3.10 AISG Multi-Wire Cable for the RRU](#)

The AISG multi-wire cable is 5 m long. It is connected to the RRU and Remote Control Unit (RCU) to transfer control signals from the base station to the RET antenna.

3.11 AISG Extension Cable for the RRU

When the distance between the RRU and the RCU is more than 5 m, an AISG multi-wire cable is not long enough to connect the RRU and RCU. In this case, the AISG extension cable is used to extend the AISG multi-wire cable for transmitting RS485 signals.

3.1 RRU3908 Cable List

The RRU3908 cables are the PGND cable, power cable, CPRI optical cable, RF jumper, interconnection jumper, alarm cable, AISG multi-wire cable, and AISG extension cable.

Table 3-1 lists the cables.

Table 3-1 RRU3908 cables

Cable Name	One End		The Other End	
	Connector	Installation Position	Connector	Installation Position
3.2 RRU PGND Cable	OT terminal (M6, 16 mm ²)	Ground terminal on the RRU	OT terminal (M6, 16 mm ²)	AC surge protection box
			OT terminal corresponding to the PGND bar on site	Ground terminal on the PGND bar
3.3 Power Cable for the DC RRU	Easy power receptacle (pressfit type) connector	NEG(-)0 and RTN (+)0 ports on the RRU	Bare wire	Power equipment
3.4 AC Power Cable for the AC RRU	3-pin round-shaped connector	AC-in port on the AC/DC conversion module of the AC RRU	OT terminal	AC surge protection box
			Bare wire	Power equipment
3.5 Monitoring Signal Cable for the AC RRU	DB15 connector	EXT_ALM port on the RRU	-	DC-out port on the AC/DC conversion module of the AC RRU
3.6 CPRI Optical Cable	DLC connector	TX and RX ports in the CPRI0 port on the RRU	DLC connector	CPRI port on the BBU

Cable Name	One End		The Other End	
	Connector	Installation Position	Connector	Installation Position
3.8 RF Jumper for the RRU	DIN male type connector	ANT_TX/RXA or ANT_TX/RXB port on the RRU	DIN male type connector	Antenna system
3.9 Interconnect Jumper for the RRU	DB2W2 connector	RX_IN/OUT port on the RRU	DB2W2 connector	RX_IN/OUT port on the RRU
3.7 Alarm Cable for the DC RRU	DB15 connector	EXT_ALM port on the RRU	Cord end terminal	External alarm equipment
3.10 AISG Multi-Wire Cable for the RRU	DB9 waterproof connector	RET port on the RRU	Standard AISG female connector	Standard AISG male connector on the RCU or on the AISG extension cable
3.11 AISG Extension Cable for the RRU	Standard AISG male connector	Standard AISG male connector on the RCU	Standard AISG female connector	Standard AISG female connector on the AISG multi-wire cable

3.2 RRU PGND Cable

The PGND cable ensures the grounding of the RRU.

Exterior

The PGND cable is green and yellow and has a cross-sectional area of 16 mm². Both ends of the cable are OT terminals. If the PGND cable is to be prepared by the customer, the copper-core cable with a cross-sectional area of 16 mm² is recommended. **Figure 3-1** shows the PGND cable.

Figure 3-1 PGND cable

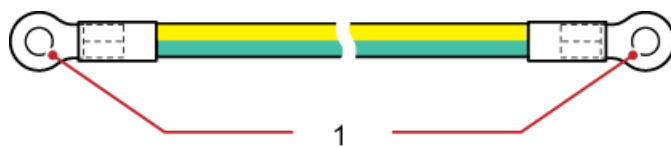

(1) OT terminal (16 mm², M6)

NOTE

- When an AC surge protection box is used, a PGND cable connects the surge protection box and the ground bar of the RRU to achieve the equipotential connection between the AC surge protection box and the RRU. The other PGND cable connects the surge protection box and a ground bar to ensure the reliable grounding of the AC surge protection box.
- One end of the PGND cable that is connected to the RRU or AC surge protection box has an M6 OT terminal, and the other end needs to be assembled with an OT terminal depending on the external ground bar on site.

OT terminals need to be added on site. You can determine the color of the cable and whether to use 2-hole terminals according to local standards.

Figure 3-2 shows the 2-hole OT terminal.

Figure 3-2 2-hole OT terminal



3.3 Power Cable for the DC RRU

The RRU power cable is the -48 V DC shielded power cable, which is used to feed the -48 V DC power into the RRU.

Exterior

The power cable has an easy power receptacle (pressfit type) connector at one end and bare wires at the other end, which must be added with a corresponding terminal based on the external power equipment, as shown in **Figure 3-3**.

Figure 3-3 Power cable for the DC RRU

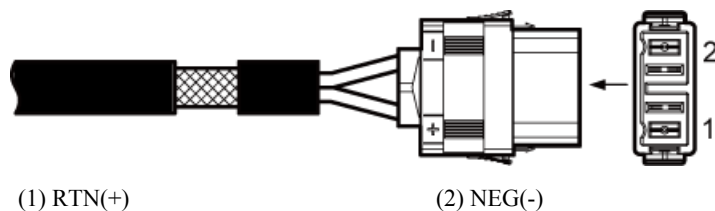

(1) RTN(+)

(2) NEG(-)

Pin Assignment

The DC RRU power cable is a 2-wire cable. [Table 3-2](#) and [Table 3-3](#) describe the pin assignment for the wires of the power cable.

Table 3-2 Pin assignment for the wires of the power cable (North American standard)

Wire Type	Color
NEG(-)	Blue
RTN(+)	Black

Table 3-3 Pin assignment for the wires of the power cable (European standard)

Wire Type	Color
NEG(-)	Blue
RTN(+)	Brown

3.4 AC Power Cable for the AC RRU

The AC power cable feeds AC power from external equipment to the AC RRU.

Exterior

[Figure 3-4](#) shows the power cable between the AC RRU and the external power equipment when the AC surge protection box is not configured.

Figure 3-4 Power cable between the AC RRU and the external power equipment

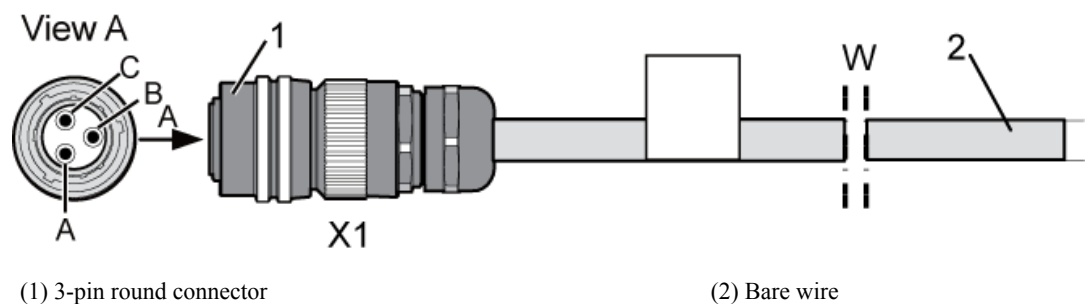

[Figure 3-5](#) shows the power cable between the AC RRU and the AC surge protection box.

Figure 3-5 Power cable between the AC RRU and the AC surge protection box

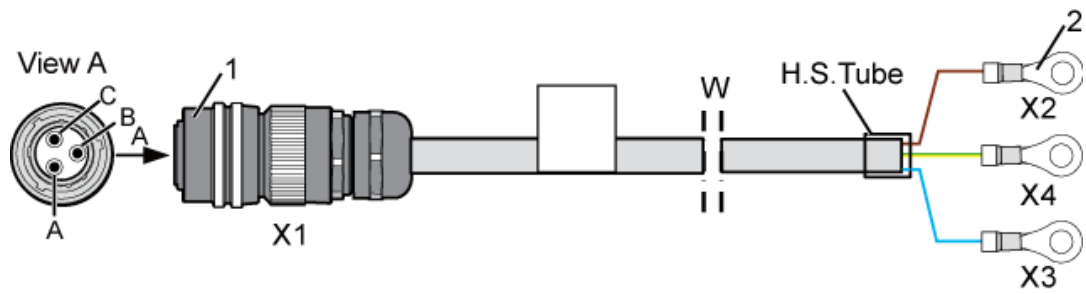

(1) 3-pin round connector

(2) OT terminal

Figure 3-6 shows the power cable between the AC surge protection box and the external power equipment.

Figure 3-6 Power cable between the AC surge protection box and the external power equipment

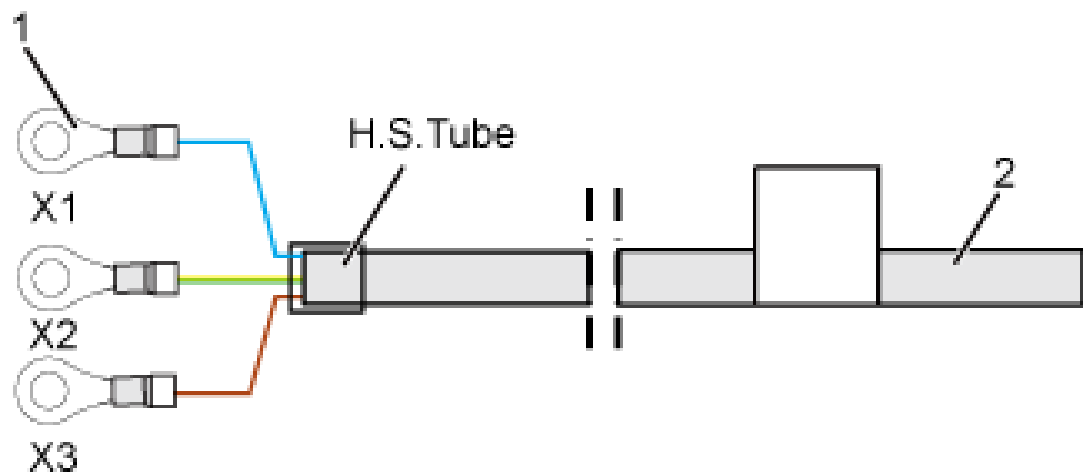

(1) OT terminal

(2) Bare wire

Pin Assignment

Table 3-4 describes the pin assignment for the power cable between the AC RRU and the external power equipment.

Table 3-4 Pin assignment for the wires of the AC power cable between the AC RRU and the external power equipment

One End (AC RRU)	The Other End (Power equipment)	Color	Description
X1.A	Bare wire	Brown	L

One End (AC RRU)	The Other End (Power equipment)	Color	Description
X1.C		Blue	N
X1.B		Green and yellow	PE

Table 3-5 describes the pin assignment for the power cable between the AC RRU and the AC surge protection box.

Table 3-5 Pin assignment for the wires of the AC power cable between the AC RRU and the AC surge protection box

One End (AC RRU)	The Other End (AC surge protection box)	Color	Description
X1.A	X2	Brown	L
X1.C	X3	Blue	N
X1.B	X4	Green and yellow	PE

Table 3-6 describes the pin assignment for the power cable between the AC surge protection box and the power equipment.

Table 3-6 Pin Assignment for the wires of the power cable between the AC surge protection box and the power supply device

One End (AC surge protection box)	The Other End (Power equipment)	Color	Description
X3	Bare wire	Brown	L
X1		Blue	N
X2		Green and yellow	PE

3.5 Monitoring Signal Cable for the AC RRU

The monitoring signal cable for the AC RRU feeds power to the AC RRU and monitors the running status of the RRU.

NOTE

The monitoring signal cable for the RRU is connected to the RRU before delivery.

Exterior

The monitoring signal cable for the AC RRU has an easy power receptacle (pressfit type) connector and a DB15 connector at one end connected to the AC RRU, as shown in [Figure 3-7](#). The other end of the monitoring signal cable is connected to the DC-out port on the AC/DC conversion module before delivery.

Figure 3-7 Monitoring signal cable of the AC RRU

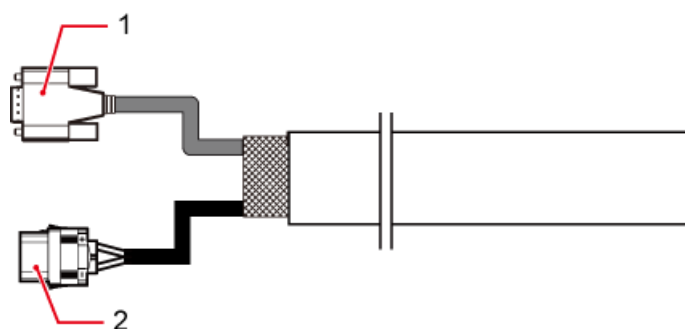

(1) DB15 connector

(2) Easy power receptacle (pressfit type) connector

Pin Assignment

[Table 3-7](#) and [Table 3-8](#) describe the pin assignment for the wires of the monitoring power cable.

Table 3-7 Pin assignment for the wires of the monitoring power cable (North American standard)

Wire Type	Color
NEG(-)	Blue
RTN(+)	Black

Table 3-8 Pin assignment for the wires of the monitoring power cable (European standard)

Wire Type	Color
NEG(-)	Blue
RTN(+)	Brown

3.6 CPRI Optical Cable

The CPRI optical cable transmits CPRI signals between the BBU and the RRU or between RRUs.

Exterior

The CPRI optical cable is categorized into the multi-mode optical cable and single-mode optical cable. When the distance between the BBU and the RRU is shorter than 100 m, a multi-mode optical cable is required. When the distance between the BBU and the RRU is longer than 100 m, a single-mode optical cable is required. A single-mode optical cable connects the BBU to the ODF and the ODF to the RRU to transmit CPRI signals.

A multi-mode optical cable is a multi-mode cable with a DLC connector at each end. **Figure 3-8** shows the multi-mode optical cable.

Figure 3-8 Multi-mode optical cable

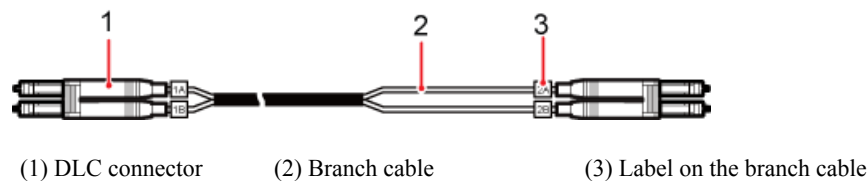

When a multi-mode optical cable is used for connection between the BBU and RRU, the branch cables on the BBU side and RRU side are 0.34 m and 0.03 m long respectively. When a multi-mode optical cable is used for connection between RRUs, the branch cables on both RRU sides are 0.03 m long.

A single-mode optical cable has a DLC connector at one end and two FC connectors at the other end, as shown in **Figure 3-9**.

Figure 3-9 Single-mode optical cable

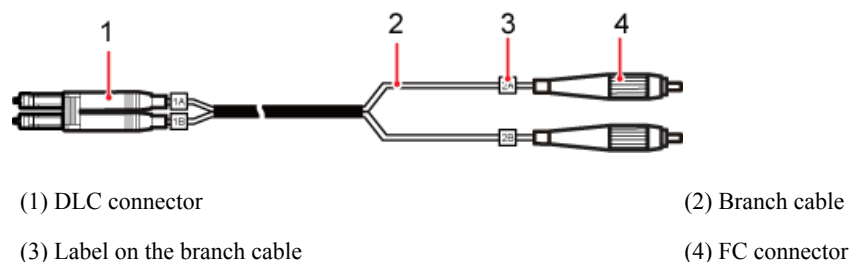

When a single-mode optical cable is used for connection between the BBU and the ODF, the branch cables on the BBU side and ODF side are 0.34 m and 0.8 m long respectively.

When a single-mode optical cable is used for connection between the ODF and RRU, the branch cables on the BBU side and ODF side are 0.03 m and 0.8 m long respectively.

NOTE

The CPRI optical cable must be connected to the optical module in the CPRI port on the BBU or RRU. The multi-mode optical cable and single-mode optical cable are used for the multi-mode optical module and single-mode optical module respectively.

Pin Assignment

Table 3-9, **Table 3-10**, and **Table 3-11** describe the labels and recommended connections for the branch cables of the CRPI optical cable.

Table 3-9 Labels and recommended connections for the branch cables of the multi-mode optical cable between the BBU and RRU

Label	Color	Installation Position
1A	Orange	CPRI RX port on the RRU
1B	Gray	CPRI TX port on the RRU
2A	Orange	TX port on the BBU
2B	Gray	RX port on the BBU

Table 3-10 Labels and recommended connections for the branch cables of the multi-mode optical cable between RRUs

Label	Color	Installation Position
1A	Orange	CPRI RX port on the RRU 1
1B	Gray	CPRI TX port on the RRU 1
2A	Orange	CPRI TX port on the RRU 0
2B	Gray	CPRI RX port on the RRU 0

Table 3-11 Labels and recommended connections for the branch cables of the single-mode optical cable and recommended connections

Label	Color	Installation Position
1A	Yellow	RX port on the BBU or CPRI RX port on the RRU
1B	Blue	TX port on the BBU or CPRI TX port on the RRU
2A	Yellow	ODF
2B	Blue	ODF

3.7 Alarm Cable for the DC RRU

The alarm cable for the RRU is a shielded straight-through cable. The cable transmits alarm signals from the external equipment to the DC RRU and monitors the external equipment.

Exterior

The alarm cable has a DB15 connector at one end and eight cord-end terminals at the other end. **Figure 3-10** shows the alarm cable.

Figure 3-10 Alarm cable

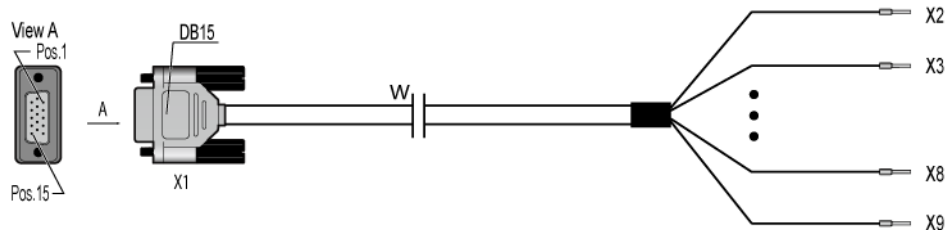

Pin Assignment

Table 3-12 describes the pin assignment for the wires of the alarm cable.

Table 3-12 Pin assignment for the wires of the RRU alarm cable

RRU Alarm Port	Pin of the DB15 Connector	Wire Color	Wire Type	Cord End Terminal	Description
Dry contact	X1.2	White/blue	Twisted pair	X2	SWITCH_INPUT0+
	X1.3	Blue		X3	SWITCH_INPUT0-(GND)
	X1.6	White/orange	Twisted pair	X4	SWITCH_INPUT1+
	X1.7	Orange		X5	SWITCH_INPUT1-(GND)
RS485	X1.10	White/green	Twisted pair	X6	APM RX-
	X1.11	Green		X7	APM RX+
	X1.13	White/brown	Twisted pair	X8	APM TX-
	X1.14	Brown		X9	APM TX+

3.8 RF Jumper for the RRU

The 1/2-inch RF jumper is used for the RRU. It transmits and receives RF signals between the RRU and antenna.

Exterior

 **NOTE**

- When the distance between the RRU and the antenna is within 14 m, one end of the RF jumper is connected to the ANT port at the bottom of the RRU, and the other end is connected to the antenna.
- When the distance between the RRU and the antenna exceeds 14 m, the RF jumper is connected to the feeder prior to the RRU and antenna. If the RF jumper is provided by the customer, the length of the RF jumper should not exceed 2 m.

The RF jumper has a DIN male connector on one end and a connector made based on field requirements on the other end. [Figure 3-11](#) shows the RF jumper where both ends are DIN male connectors.

Figure 3-11 RF jumper

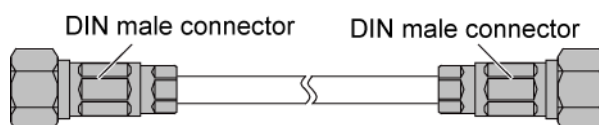

3.9 Interconnect Jumper for the RRU

The interconnect jumper for the RRU connects the **RX_IN/OUT** ports of two RRUs, and transmits the RF signals between the RRUs in the same cell.

Exterior

The interconnect jumper has a DB2W2 connector on each end. [Figure 3-12](#) shows the interconnect jumper.

Figure 3-12 Interconnect jumper

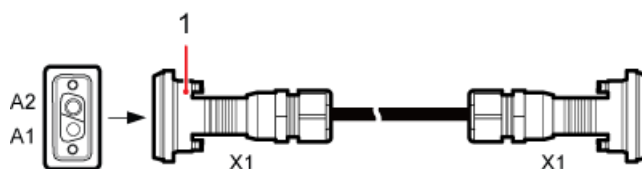

(1) DB2W2 connector

3.10 AISG Multi-Wire Cable for the RRU

The AISG multi-wire cable is 5 m long. It is connected to the RRU and Remote Control Unit (RCU) to transfer control signals from the base station to the RET antenna.

NOTE

The RCU is a driving motor used for the phase shifter in the RET antenna. It receives the control commands from the base station and executes the commands to drive the step motor, which drives the phase shifter in the antenna through the gearing to adjust the tilt angle of the antenna.

Exterior

The AISG multi-wire cable has a DB9 waterproof connector at one end and an AISG standard female connector at the other end, as shown in [Figure 3-13](#).

Figure 3-13 AISG multi-wire cable

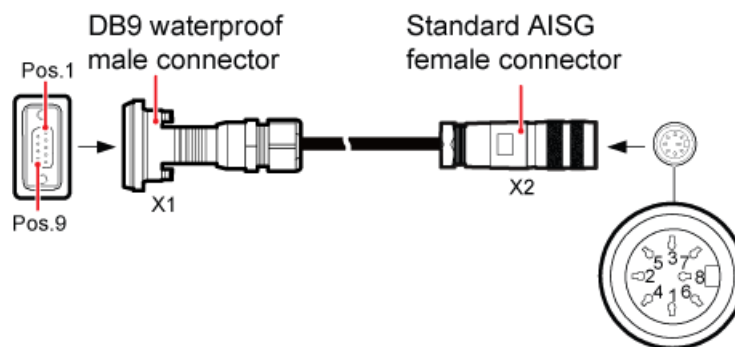

Pin Assignment

[Table 3-13](#) describes the pin assignment for the wires of the AISG multi-wire cable.

Table 3-13 Pin assignment for the wires of the AISG multi-wire cable

X1 End (Pin of the DB9 Waterproof Connector)	X2 End (Pin of the Standard AISG Female Connector)	Wire Color	Wire Type	Pin Assignment
X1.1	X2.1	White and blue	Twisted pair	+12V
		blue		
X1.3	X2.3	White and orange	Twisted pair	RS485 B
X1.5	X2.5	orange		RS485 A
X1.4	X2.4	White and green	-	RS485 GND

X1 End (Pin of the DB9 Waterproof Connector)	X2 End (Pin of the Standard AISG Female Connector)	Wire Color	Wire Type	Pin Assignment
X1.9 is connected to X1.4.	-	-	-	-
-	X2.1 is connected to X2.6.	-	-	-
-	X2.4 is connected to X2.7.	-	-	-

3.11 AISG Extension Cable for the RRU

When the distance between the RRU and the RCU is more than 5 m, an AISG multi-wire cable is not long enough to connect the RRU and RCU. In this case, the AISG extension cable is used to extend the AISG multi-wire cable for transmitting RS485 signals.

Exterior

The AISG extension cable has a standard AISG male connector on one end and a standard AISG female connector on the other end, as shown in [Figure 3-14](#).

Figure 3-14 AISG extension cable

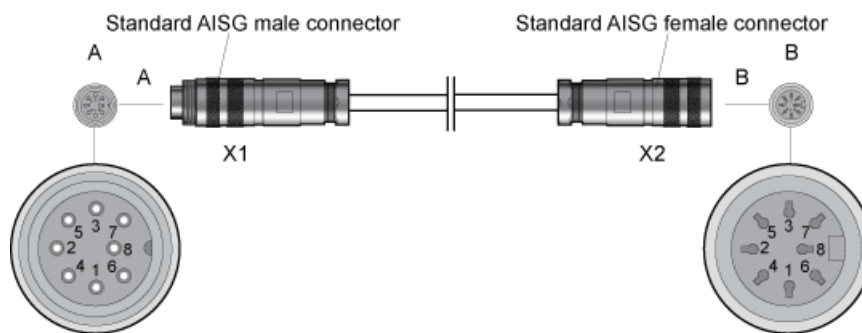

Pin Assignment

[Table 3-14](#) describes the pin assignment for the wires of the AISG extension cable.

Table 3-14 Pin assignment for the wires of the AISG extension cable

X1 End (Pin of the Standard AISG Male Connector)	X2 End (Pin of the Standard AISG Female Connector)	Color	Wire Type	Core Description
X1.1	X2.1	White and blue	Twisted pair	+12 V
		Blue		
X1.7	X2.7	White and orange	Twisted pair	DC Return A
		Orange		
X1.3	X2.3	White and green	Twisted pair	RS485 B
X1.5	X2.5	Green		RS485 A
X1.6	X2.6	White and brown	Twisted pair	+24 V
		Brown		

4 Auxiliary Devices of the RRU

About This Chapter

The auxiliary devices of the RRU consist of the AC power surge protection box, Indoor Floor installation Support (IFS06), and Outdoor Cable Conversion Box (OCB).

[4.1 AC Power Surge Protection Box](#)

The AC power surge protection box is used to provide surge protection for AC power.

[4.2 IFS06](#)

The Indoor Floor installation Support (IFS06) is used for installing RRUs indoors.

[4.3 OCB](#)

The Outdoor Cable Conversion Box (OCB) interconnects cables of different core diameters. The power cables shipped with the RRU cannot support long-distance power transfer. Therefore, when the power supply is far from the equipment, the OCB can be used to connect the power cable of the RRU and a cable with a large core diameter, which can transfer power for a long distance.

4.1 AC Power Surge Protection Box

The AC power surge protection box is used to provide surge protection for AC power.

Exterior

Figure 4-1 shows the AC power surge protection box.

Figure 4-1 AC power surge protection box

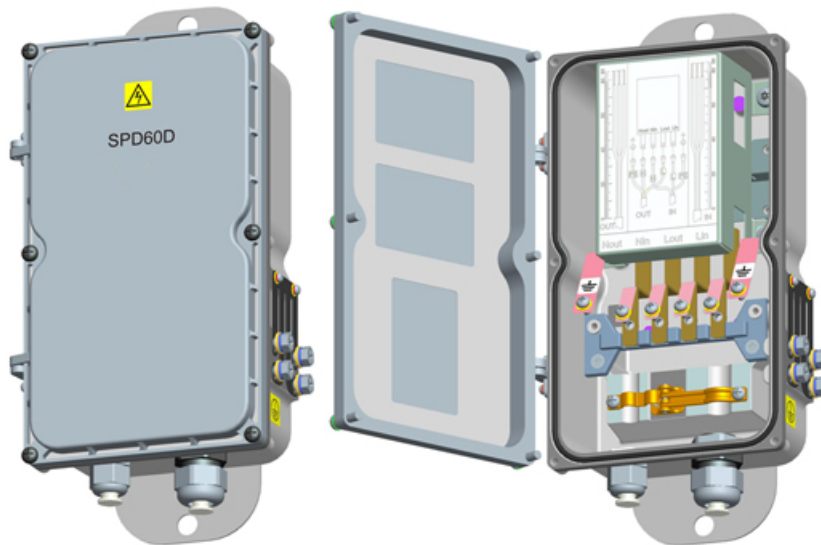

Specifications

Table 4-1 describes the specifications of the AC power surge protection box.

Table 4-1 Specifications of the AC power surge protection box

Item	Description
Height (mm) x Width (mm) x Depth (mm)	240 x 140 x 75
Installation mode	Supports installation on the pole, on the wall, and assembled installation
Surge protection class	Differential mode/common mode (60 kA): 8/20 us

Ports

Table 4-2 describes the ports on the AC power surge protection box.

Table 4-2 Ports on the AC power surge protection box

Item	Label	Description
(a) Bottom panel	IN	Port for AC power input
	OUT	Port for output of the protection power cable
(b) Side panel	-	Port for connection to the external ground cable
	-	Port for the ground cable of the RRU
(c) Cabling cavity panel	Nout	Wiring post for the power cable
	Nin	
	Lout	
	Lin	

4.2 IFS06

The Indoor Floor installation Support (IFS06) is used for installing RRUs indoors.

Exterior

[Figure 4-2](#) shows the IFS06.

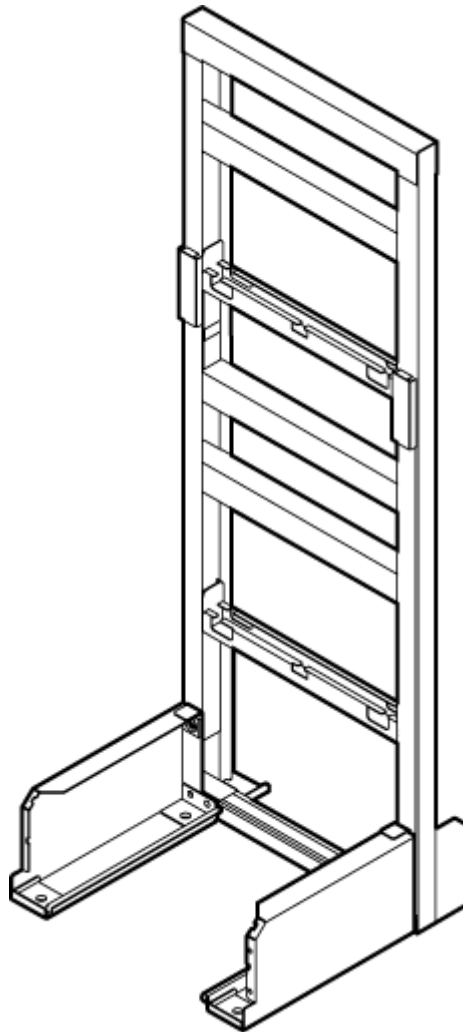
Figure 4-2 IFS06

Function

- It can be installed on the floor.
- It supports installation of six RRUs.
- The upper and lower adjustable beams on the IFS06 can be moved up and down to fit for the height of the RRUs.

Structure

The IFS06 consists of the main frame, cable rack, upper and lower adjustable beams, and front and rear feet, as shown in [Figure 4-3](#).

Figure 4-3 Structure of the IFS06

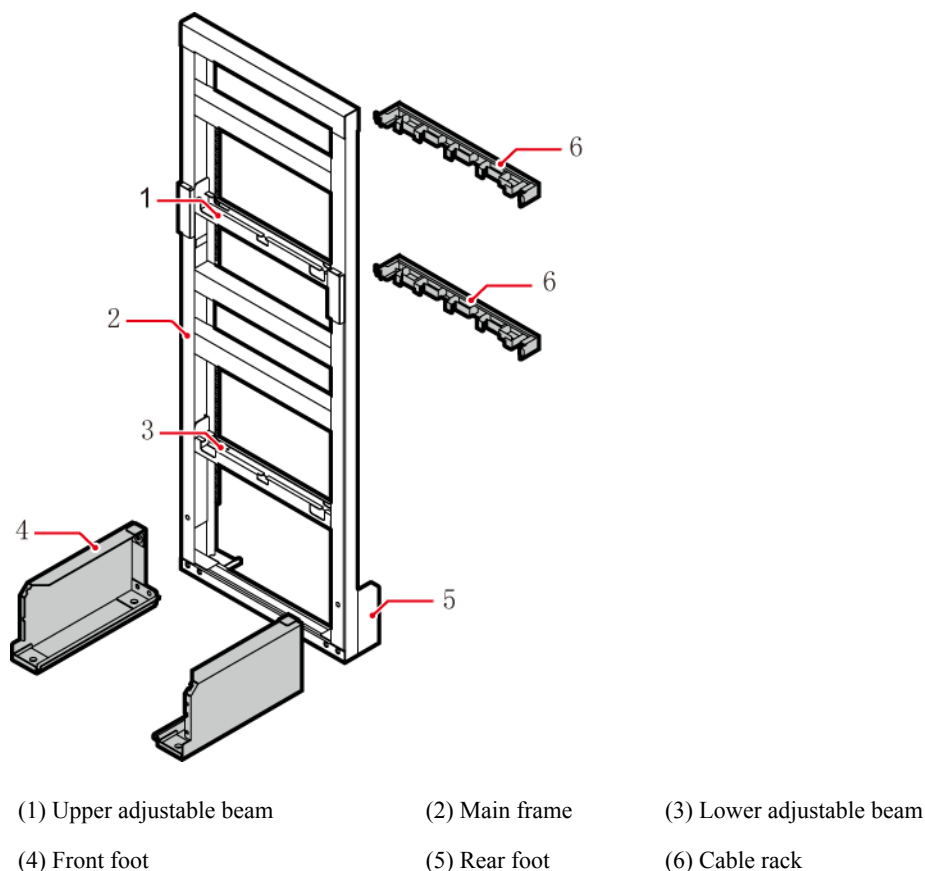

Specifications

Table 4-3 lists the specifications of the IFS06.

Table 4-3 Specifications of the IFS06

Item	Specification
Dimensions	1730 mm x 600 mm x 600 mm (height x width x depth)
Weight	45 kg

4.3 OCB

The Outdoor Cable Conversion Box (OCB) interconnects cables of different core diameters. The power cables shipped with the RRU cannot support long-distance power transfer. Therefore, when the power supply is far from the equipment, the OCB can be used to connect the power cable of the RRU and a cable with a large core diameter, which can transfer power for a long distance.

Application Scenario

The application scenario of the OCB is shown in [Figure 4-4](#).

Figure 4-4 The application scenario of the OCB

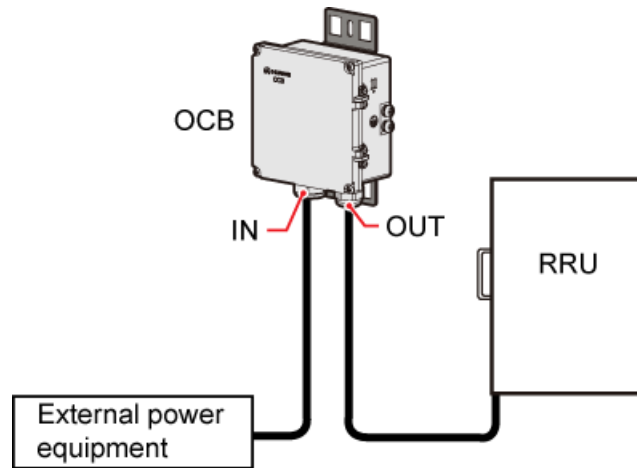

For details about the structure, functions, installation, and maintenance of the OCB, see the *OCB User Guide*.